

TABLE OF CONTENTS
Email address ccfair@midrivers.com
Fair Hall Phone 775-6384
4-H INDOOR PROJECTS

Dept. JJ	Division 1 Aerospace-----	7
Dept. CC	Division 2 Arts/Fine Arts -----	8
Dept. AA	Division 3 Beef-----	8
Dept. JJ	Division 4 Bicycle -----	10
Dept. AA	Division 5 Cat -----	11
Dept. FF	Division 6 Child Development/Babysitting ---	12
Dept. FF	Division 7 Clothing and Textiles-----	15
Dept. KK	Division 8 Cloverbuds-----	18
Dept. KK	Division 9 Crop Science -----	18
Dept. AA	Division 10 Dairy Cow-----	20
Dept. AA	Division 11 Dairy Related Products -----	21
Dept. AA	Division 12 Dog-----	22
Dept. JJ	Division 13 Electricity -----	24
Dept. JJ	Division 14 Entomology -----	25
Dept. KK	Division 15 Exploring 4-H-----	26
Dept. FF	Division 16 Family Adventures -----	27
Dept. HH	Division 17 Food & Nutrition -----	27
Dept. II	Division 18 Food Preservation -----	33
Dept. KK	Division 19 Forestry -----	35
Dept. AA	Division 20 Goat -----	36
Dept. FF	Division 21 Home Environment -----	37
Dept. AA	Division 22 Horse-----	38
Dept. LL	Division 23 Horticulture/Gardening -----	40
Dept. FF	Division 24 Leadership-----	45
Dept. JJ	Division 25 Leather craft-----	46
Dept. FF	Division 26 Needlework -----	48
Dept. FF	Division 27 Outdoor adventure -----	50
Dept. NN	Division 28 Photography-----	51
Dept. KK	Division 29 Pocket Pets -----	54
Dept. AA	Division 30 Poultry -----	55
Dept. JJ	Division 31 Quilting-----	56
Dept. AA	Division 32 Rabbit-----	57
Dept.. KK	Division 33 Range Management -----	59
Dept. JJ	Division 34 Robotics -----	60

Dept. CC	Division 35 Scrapbook -----	60
Dept. JJ	Division 36 Self-Determined (non livestock) -	61
Dept. AA	Division 37 Sheep-----	61
Dept. JJ	Division 38 Shooting Sports-----	63
Dept. CC	Division 39 Short-term -----	64
Dept. AA	Division 40 Small Engines-----	65
Dept. JJ	Division 41 Sport fishing -----	67
Dept. JJ	Division 42 Swine -----	67
Dept. CC	Division 43 Theater Arts-----	69
Dept. JJ	Division 44 Veterinary Science -----	70
Dept. KK	Division 45 Weed Science -----	71
Dept. JJ	Division 46 Wildlife Conservation -----	72
Dept. JJ	Division 47 Woodworking-----	73
Dept. CC	Division 48 Writing Arts-----	75
4-H & FFA LIVESTOCK PROJECTS -----		78
Dept.. AP	Division 1 Beef-----	78
Dept. AP	Division 2 Cat -----	80
Dept. AP	Division 3 Dairy Cow -----	80
Dept. AP	Division 4 Dog -----	81
Dept. AP	Division 5 Goat-----	82
Dept. AP	Division 6 Horse -----	86
Dept. AP	Division 7 Poultry-----	127
Dept. AP	Division 8 Rabbit -----	130
Dept. AP	Division 9 Self Determined (All Livestock)-	130
Dept. AP	Division 10 Sheep-----	131
Dept. AP	Division 11 Showmanship -----	132
Dept. AP	Division 12 Swine -----	134
Dept. AP	Division 13 Wool & Fiber -----	135
Dept. Q	AGRICULTURAL EDUCATION -----	137
Scrapie Information page -----		138
Special Youth Awards list -----		139
Livestock Buyers-----		140
4-H /FFA Award Contributors -----		141

CARTER COUNTY FAIR & RODEO PROGRAM

Rodeo Entries Open 10.a.m. Monday Close 10:00 p.m. Monday

Contact Jo Kittelmann 775-6713

Fair Building Phone 775-6384

Email ccfair@midrivers.com

Monday thru Wednesday Fair Building open 10am – 8pm

THURSDAY:

8:00 a.m.----- Carter County Fair building opens

9:30 a.m.-----Indoor exhibits must be in place

12:00 p.m. -----Fair building closed for indoor exhibit judging

-----Horses in place (**option to take home but
must be in place Saturday at 9:00 a.m.**)

1:00 p.m. -----Horse judging

2:00 p.m. -----Dog judging, Cats to follow

8:00 p.m.----- Fair building will close

FRIDAY:

8:00 a.m.----- Fair building open

8:30 a.m.----- Sheep and Goats must be in place

9:00 a.m.----- Sheep judging

----- Goat judging to follow

10:00 a.m. to 4:00 p.m. ----- **Artists of the Prairie Art Show**
At Grade School Gym thru Sunday

12:00 p.m. -----Poultry and Rabbits in place

1:00 p.m.----- Poultry judging with Rabbits to follow

4:00 p.m. to 7:00 p.m. ----- **Fireman's Barbecue**
Carter County High School Tuggle Room

7:00 p.m.----- Fair building will close

11:00 p.m.----- Fair grounds will be locked

SATURDAY:

8:00 a.m.----- Fair Building will open

8:30 a.m.----- Swine and Beef must be in place

9:00 a.m.----- Swine judging with beef to follow

10:00 a.m. to 5:00 p.m.----- **Artists of the Prairie Art Show**

4-H FFA Award Contributors

- 1:00 p.m.** -----Round Robin
- 3:00 p.m.** -----**Market Sale**
- 4:00 p.m.**----- **Stick Horse Rodeo** (3 to 6 year olds)
(Sponsored by the Miles City Stockman Bank)
- 5:00 p.m.**-----**RODEO** (Sponsored by Ekalaka Track & Arena)
- 8:00 p.m.**-----**Gospel Sing - Baptist Church**
Fair building will close
- 11:00 p.m.** ----- Fair grounds will be locked
- SUNDAY:**
- 7:00 a.m. to 10:00 a.m.**---- **Saint Joan of Arc Pancake Breakfast**
At the Saint Joan of Arc Parish Hall
- 9:00 a.m.**-----Fair building will open
- 9:00 a.m.**----- **Church Service at Rodeo Grounds**
- 10:00 a.m.**Fair Building will close for parade - will reopen after parade
- 11:00 a.m.** -----**Days of '85 Parade**
(Sponsored by the Carter County Chamber of Commerce)
- 11:00 a.m. to 5:00 p.m.**----- **Artists of the Prairie Art Show**
At the Grade School Gym
- 1:00 p.m.**----- **4-H and FFA Awards**
- 2:00 p.m.**-----**RODEO** (Sponsored by Ekalaka Track & Arena)
- 4:00 p.m.**-----Release of Market sale animals
- 5:00 p.m.**----- Exhibits may be picked up

**All exhibits must be picked up by 1 hour after
conclusion of the rodeo unless prior arrangements
have been made**

- | | |
|-------------------------------------|-------------------------------------|
| A & A Stieg | In Memory of Ernest Knipfer |
| Allison's Pantry/Deb Stieg | In Memory of Vernon Knipfer |
| Arne Sutton Insurance Agency | Insurance Store/Dale Boggs |
| AVON-Alicia Knapp | J & M Lumber |
| B & J Convenience Store | James R. Campbell, DDS |
| Baker Rexall Drug | Jesperon Construction |
| Baker Rexall Drug | John R. Tooke |
| Bentz Equipment Inc. | JUST BALLOONS-Vicki Fix |
| Bonsell Family | Keith & Sharon Schwartz |
| Borchgrevink Livestock | Laird Flying Service |
| Broadus Insurance, Inc. | Laurice's Salon |
| Brown's Custom Feeds | Mainstreet Market |
| Carter County Conservation District | Medicine Rocks Ranch |
| Carter County Fairboard | Mills Auction Service |
| Carter County FFA | Motive Parts & Supply |
| Dahl Memorial Healthcare | O'Connor Veterinary Service |
| Dell Dague Trucking | R & W Livestock Products |
| Eastern Montana Express | Red Greenhouse/Doug Marston |
| Ed Kennedy Insurance | Reynolds Grocery |
| Ekalaka Eagle | Richard O. Harkins, Attorney at Law |
| Equity Coop | RodeoRigs.com |
| Ernie Smith | Schwan's Food Company |
| Fallon Carter Extension Service | Southeast Electric Cooperative |
| Farm Credit Services | Stevenson Funeral Homes |
| First National Bank | Superior Livestock Video Auction |
| Fruit Service | Tauk Targhees-Jeff Tauk |
| H & B Construction | The Dinner Bell |
| HAIR AFFAIR-Sonja Bruski | Top Hand Welding |
| Hammel Ranch Red Angus | Trail's End Ranch |
| Hanify Veterinary Clinic | Wagon Wheel Cafe |
| Hardware Hank | Waterland Shearing |
| Horizon Implement Co | West Tire & Alignment |
| In Memory of Becky Coisman | Willard Homemakers |

2009 Carter County Youth Livestock Sale Buyers

Bank of Baker
Beach Farms
Belle Fourche Livestock
DeGrand Angus
Farmer's Elevator Glendive
First National Bank
Fruit Service
Knapp Ranch- Hysham
Reynolds Supermarket- Baker
Southeast Electric
St. Onge Livestock
Stockman's Bank
Western Ranch Supply
Wolenetz & Sons
Ben Holt
Mills Auction
Sundance Equipment
Milton & Lindsey Tope
Miles City Livestock
Wolff Ranch Inc.

Friends of 4-H Plaque Buyers

Medicine Rocks Ranch
Equity Co-op

WEIGH IN TIMES
FRIDAY 7 TO 8 A.M. & 5 TO 6 P.M.
SATURDAY 8 TO 9 A.M.

**All 4-H ENTRY FORMS MUST BE TO THE FAIR OFFICE
BY 6 P.M. WEDNESDAY THE WEEK OF THE FAIR**

Entries must be received by 6 p.m. Wednesday before the fair they may be dropped off at the fair hall the week of the fair or mailed to P.O. Box 164
Email ccfair@midrivers.com

- 1 Contact the Fair Secretary for the tags. Please put your age (4-H age), name of your project & Unit you are in on your exhibitor tags.
- 2 All entries must be approved by the County Extension Agent, local club leaders.
- 3 Fallon/Carter Extension Service reserves the right to interpret these 4-H rules and regulations and settle and determine all matters, questions and differences in regard to 4-H
- 4 All exhibits in this department will be judged on the Danish / Groups System of placing. First group blue; second group red; third group white. If no exhibit in a lot merits a ribbon, none will be given.
- 5 Only one entry in any class by exhibitor throughout all the departments except where stated.
- 6 Judges' decision is final.
- 7 Exhibitors will not receive premium monies if they remove their exhibits from the fair grounds before the specified time.
- 8 Posters no larger than 14x22 Criteria for judging posters is as follows:
Originality - 25% Neatness - 25% Tells a story - 50%
- 9 Member's 4-H Clubs in Carter County and surrounding counties are eligible to exhibit in this department. All members must be carrying the project in which they are entering exhibits.

Contestants will be divided into three divisions:

- Senior Division: Members must be 14 years or age or older October 1 of current 4-H year.
- Junior Division: Members 13 years of age or younger before October 1 of current 4-H year.
- Novice Division: Members showing this specie for the first time who would like to take part in a learning experience designed to prepare them for future competition.

(4-H year is from Oct 1 to Sept 30)

LOW BRACKET: 4-2-1

MEDIUM BRACKET: 5-3-2

HIGH BRACKET: 7-4-2

The point value equals \$1.00

Silent Auction

**This new event for the Carter County Fair
Is open to all entered 4-H, FFA, FCCLA Indoor
Projects.**

**Items for this event will need to be identified on
the entry form. Write the words Silent Auction
Item after description of item.**

**Entries for this event will be entered in the fair
as you would normally, receiving ribbons and
premiums. Following the judging the items will be
placed in the auction area, where they will be bid
upon until the conclusion of the auction.**

**The bidding will be in increments of \$1.00, the
highest bidder at the end of the auction will take
home the item after payment.**

**The auction will run for Friday 8:00 am until
Sunday 2 pm Items may be paid for and picked up
after 5:00 pm on Sunday**

SPECIAL YOUTH AWARD LIST

MONTANA ANGUS ASSOCIATION will award a belt buckle to the top 4-H or FFA Black Angus Breeding Exhibit.

MONTANA ANGUS AUXILIARY will offer a jacket award to the top 4-H or FFA overall breeding exhibit winner if Black Angus and has competed against at least three other exhibitors.

The Montana Hereford Association will award a wind breaker jacket to the exhibitor of a Grand Champion Steer if properly documented as a Hereford, to the Top Steer of Merit on the county level if the animal is at least 50% Hereford ancestry and to the Top Breeding Female if a purebred Hereford.

The Montana Simmental Association will give an award for the Grand Champion Market Steer, Grand Champion Carcass and Grand Champion Female for 4-H or FFA, if the animal is identified on their stall or barn card as being Simmental or Simmental cross.

The Montana Gelbvieh Association will pay \$10 to any 4-H or FFA exhibitor who receives a blue ribbon on their Gelbvieh or Gelbvieh-cross animal at a county fair. In addition Grand and Reserve Champion animals, where competing in a minimum group of 5, will receive \$25 and \$15 respectively.

The American Salers Association will offer \$100 for a steer and \$50 for a heifer if the animal is a Grand Champion, competed in a multi-breed competition and is a least 50% Salers out of a registered Salers sire or female. Eligible 4-H and FFA youth must submit a completed application and picture of animal.

Equity Co-Op of Baker will award a belt buckle to the Grand Champion Market Steer, Grand Champion Market Swine, and Grand Champion Market Sheep.

Willard Homemakers will award a cookbook to the exhibitor with the most 4-H food exhibits entered

Keith and Sharon Schwartz will award \$25.00 to the 4-H member receiving the most blue ribbons on indoor exhibits and \$15.00 to the 4-H member receiving the second most blue ribbons on indoor exhibits.

Special 4-H Indoor Awards

The individual 4-H Member with the most outstanding 4-H Centennial Display will receive a special award.

The 4-H Club with the most outstanding 4-H Centennial Display will receive a special award.

New rules for sheep and goats

The Rule: The USDA has enacted a mandatory program to eradicate the disease scrapie from sheep and goats in the US. The program requires an official ID on sheep and goats. The rule also states that sheep and goats for exhibition (shown at fairs) are required to have an official scrapie ID.

What is scrapie? Scrapie is a fatal, degenerative disease affecting the central nervous system of sheep and goats. Animals sold from infected flocks spread scrapie to other flocks. The presence of scrapie in the U.S. also prevents the export of breeding stock, semen, and embryos to many other countries.

How does this apply to our fair? The rule clearly states that all breeding sheep and goats at the fair are required to have an official scrapie ID. At a minimum, all market sheep and goats except castrated males less than 18 months of age are required to have an official ID. However, it may be easier for us to expand the tag requirement to all sheep and goats rather than to have to differentiate between ewe and wether lambs. This recommendation is endorsed by the Montana Scrapie Committee.

Where do we get tags?

OPTION 1:

The producer who raises the lamb or goat can tag the lamb prior to the purchase by the 4-H'er.

OPTION 2:

Your local veterinary service can order tags from the State APHIS Office.

Tags are free of charge.



© SIMBISI TECHNOLOGIES, INC.
ART1014.2014

4-H YOUTH INDOOR CLUB WORK

DEPT JJ Division 1 - AEROSPACE

Division 1A -Aerospace Level 1 - Lift-Off (5, 3, 2)

Class

- 1 Simple rocket with pre-formed fins
- 2 Rocket with fins that need to be aligned, sanded and glued
- 3 Report on an aerospace career
- 4 Set of three different types of paper airplanes
- 5 Notebook on different types of aircraft
- 6 A chart on one week's weather and your analysis of flying conditions
- 7 A homemade diamond kite
- 8 Model of a hot air balloon with parts identified
- 9 Poster or notebook identifying the parts of an airplane
- 10 Project manual
- 11 Any other project-related item

Division 1 B -Aerospace Level 2-Reaching New Heights (5, 3, 2)

Class

- 1 Skill level 2 rocket
- 2 Rocket you have designed and built with simple materials from your home (no engine)
- 3 A flight simulator you have made
- 4 A feather wing glider
- 5 A model airplane
- 6 A model helicopter
- 7 A homemade fighter kite that can roll, pitch and yaw
- 8 Poster or notebook identifying parts of a helicopter & their functions
- 9 Poster or notebook identifying parts and functions of a remote control airplane
- 10 Project manual
- 11 Any other project-related item

Division 1C -Aerospace Level 3 - Pilot in Command (5, 3, 2)

Class

- 1 Design & build two-stage rocket that will reach altitude of 2,000 feet
- 2 Your own constructed altitude tracker
- 3 Your chart of a route over 2,000 miles in length considering winds, clouds, temperature, precipitation, terrain, fuel and airports
- 4 A flat-style box kite
- 5 Notebook on the history of aviation
- 6 Notebook on the history of the space program

- 7 Complete cost and feasibility analysis of establishing an EMS helicopter service in your local community
- 8 An advanced model rocket
- 9 A model airplane
- 10 Project manual
- 11 Any other project-related item

**DEPT CC Division 2 – ARTS/FINEARTS
Division 2A –Arts K-6 (Points 5,3,2)**

Class

1. Item you have made incorporating cutting and pasting
2. Item you have made incorporating drawing
3. Item you have made incorporating painting
4. Item you have made incorporating sculpting
5. Item you have made incorporating printing
6. Item you have made incorporating fiber
7. Item you have made incorporating 3-D construction
8. Any other project related item

**DEPT AA Division 3 - BEEF
Division 3A -Beef 1 - Bite into Beef (Points 4, 2, 1)**

Class

- 1 Poster or display showing equipment needed to groom a beef animal for showing.
- 2 Samples of what a beef animal eats
- 3 A collection of pictures and information on major beef breeds
- 4 A completed Calf Health Chart
- 5 Poster of at least 10 Beef By-products, where they are found and their use
- 6 A chart showing a Beef Animal Care Schedule
- 7 A journal stating how cows (you have observed) relate to one another and of the care they are provided
- 8 Poster with pictures & captions showing steps in caring for a newborn calf
- 9 A collection of at least 10 labeled feed ingredients fed to beef cattle
- 10 Poster of four different pictures of steers and heifers and comparisons of each along with a ranking
- 11 Poster with map identifying countries of origin of at least 10 beef breeds

DEPARTMENT Q

**AGRICULTURAL EDUCATION
(Points 5-3-2)**

Exhibits must be approved by Agricultural Education instructor. Follow all open class rules for grains, and horticulture. Refer to those divisions.

Class

1. Class room notebook (Ag I, Ag II, Ag III, Ag IV, & Ag-Science)
2. Sheaf grain- collected by Ag-Ed student for class assignment or part of the SAE (state type)
3. Threshed grain (one gallon each).collected by Ag-Ed student for class assignment or part of the SAE (state type)
4. Sheaf Forage- collected by Ag-Ed student for class assignment or part of the SAE (state type)
5. Wood Project - Project shall consist of any wood project done in an Ag-Ed class or as part of an SAE.
6. Metal Project - Project shall consist of any metal project done in an Ag-Ed class or as part of an SAE.
7. Range and Crop Management Paper - Paper shall consist of student's management plan for a farm or ranch. Must map all existing management tools, as well as new items that will be implemented to increase the efficiency of the ranch. May be computer version done in a variety of software.
8. Ag Computer Design. Shall consist of a project done in Microsoft Excel, Access, Word, Front Page, Publisher or Power Point. Student should have paper version as well as a copy available CD.
9. Specialty Animals
10. Other - Any other projects or item done by an Ag-Ed student for class, FFA, or as part of an SAE.

(SAE = Supervised Agriculture Experience)

Division 13C - Mohair (fiber)

Class

1. Fall clip - first clip, kid hair
2. Spring clip - second clip, kid hair
3. Yearling
4. Adult

Division 13D - Pygora (fiber)

Class

1. Type A Fleece - winter clip
2. Type B Fleece - 1 season of shearing, combing or plucking
3. Type C Fleece - Spring combing or plucking

Division 13E - Cashmere (fiber)

Class

1. 1 years combing or shearing kid
2. 1 years combing or shearing yearling
3. 1 years combing or shearing adult

Division 13F - Cashgora (fiber)

Class

1. Fall clip - first clip, kid hair
2. Spring clip - second clip, kid hair
3. Yearling
4. Adult

Division 13G - Nugora (fiber)

Class

1. Type A Fleece - winter clip
2. Type B Fleece - 1 season of shearing, combing or plucking
3. Type C Fleece - Spring combing or plucking

12. Poster or display comparing three breeds from different areas of the world and how they are uniquely adapted to their environment.
13. Poster or display comparing cattle of three different ages on time spent sleeping, idle, drinking, ruminating and grazing or eating
14. Poster of your drawing of beef animal with at least 30 body parts labeled
15. Poster with a picture and explanations of the ideal beef animal
16. Poster of beef animal showing locations of retail beef cuts
17. Project manual
18. Any other project-related item

Division 3B -Beef 2 - On the Moove (Points 4, 2, 1)

Class

1. Poster or educational display on yield and carcass composition
2. Educational display or notebook on different household items made from a beef animal
3. Educational chart on Beef Cattle feed ingredients
4. Educational poster on the digestive system of a beef animal
5. Set of five calf nose prints; point out the differences
6. Collection of information on behavior of five different beef animals
7. Educational notebook or display on cattle diseases, their symptoms, and the prevention
8. Poster with a beef shopper's chart with nine types of beef products
9. Collect, evaluate and report on at least three different feed tags.
10. Results of interviewing at least four different people on issues that affect the beef industry
11. Promotional display of your beef animal (picture and captions)
12. Project manual
13. Any other project-related item

Division 3C -Beef 3 - Leading the Charge (Points 4, 2, 1)

Class

1. A judging card and full set of reasons written out on a class of four bulls
2. A list of important traits to look for in a feeder calf and an explanation of each trait
3. A lean price comparison chart of two T-bone steaks and a muscle tenderness comparison chart of the longissimum and tenderloin part of each steak
4. A report addressing issues affecting today's beef industry

- 5 A collection of cards or a poster listing at least ten beef issues and how biotechnology has or could solve this issue
- 6 A poster promoting beef and beef by-products
- 7 A copy of a newspaper article you have written and had published promoting beef and beef by-products
- 8 A poster or educational display of at least five different knots and an explanation of when and how to use them
- 9 A rope halter you have made
- 10 A chart showing calculated rate of gain on a steer you have frame scored. Market time is set for Saturday of your local fair.
- 11 A poster of a beef breeding program you would like to develop
- 12 Poster, notebook, or educational display on at least five beef industry careers
- 13 A budget you have developed for a beef enterprise and an evaluation of this budget by a loan officer or experienced adult
- 14 Project manual
- 15 Any other project-related item

DEPT JJ Division 4 - BICYCLE (Points 4, 2, 1)

Judge will determine most outstanding Bicycle Exhibit which will be eligible to advance to the Champion of Champions Contest at the Eastern Montana Fair.

Division 4A -Unit I - You and Your Bicycle

Class

- 1 Notebook on project
- 2 Educational display
- 3 Project book
- 4 Any other project-related item
- 5 Any other project-related item

Division 4B -Unit II - Caring For Your Bicycle

Class

- 1 Notebook on project
- 2 Educational display
- 3 Project book
- 4 Any other project-related item
- 5 Any other project-related item

Division 4C -Unit III - Mastering Bicycle Skills

Class

- 1 Notebook on project
- 2 Educational display
- 3 Project manual

2. Pen of 3 Market Swine (individual or club entry)
3. Weaned feeder hogs
4. Pen of 3 weaned feeder hogs (individual or club entry)
5. Feeder swine born during the current season

Division 12B -Breeding Swine

Individual exhibits of gilt and boar under 1 yr. May be shown or used as part of class shown as litter.

	Gilt under 1 yr	Sow over 1 yr	Boar under 1 yr	Boar 1 yr & under 2	Litter of 4 or more
Duroc	1	2	3	4	5
Poland China	6	7	8	9	10
Hampshire	11	12	13	14	15
Yorkshire	16	17	18	19	20
Landrace	21	22	23	24	25
Chester White	26	27	28	29	30
Other	31	32	33	34	35
Crossbred	36	37			38

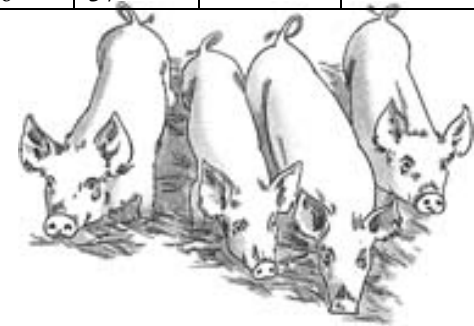

Dept AP Division 13 - WOOL (Points 4, 2, 1)

- The purpose of this show is to educate wool growers toward the producing higher-value fleeces. Twelve months' growth of wool is the minimum permitted, except in the case of yearling fleeces.
- All entries must be in the name of the grower. Facts affecting exhibit are: discoloration by excessive moisture and weakness of staple.
- DO NOT insert lot number—this will be determined by the judge.

Division 13A -Ewe Wool

Class

1. Fine staple
2. Half-blood combing
3. 3/8 blood combing
4. Quarter blood

Division 13B -Ram Wool

Class

1. Fine staple
2. Half-blood combing
3. 3/8 blood combing
4. Quarter blood

11. Junior Goats
12. Novice Goats
13. Senior Fiber Goat
14. Junior Fiber Goat
15. Novice Fiber Goat
16. Senior Swine
17. Junior Swine
18. Novice Swine
19. Senior Sheep
20. Junior Sheep
21. Novice Sheep
22. Senior Poultry
23. Junior Poultry
24. Novice Poultry
25. Senior Rabbit
26. Junior Rabbit
27. Novice Rabbit
28. Senior Dog
29. Junior Dog
30. Novice Dog
31. Senior Cat
32. Junior Cat
33. Novice Cat

Dept AP Division 12 - SWINE (Points 7, 4, 2)

- All swine will be shown with a cane in the sheep show ring. Member must have possession of animal by June 1st. Commercial-finish weight is 235 to 280 lbs.
- Member can be registered in any level of Swine project to exhibit Market Swine or Breeding Swine at the fair, but same animal can not be entered in both market division and breeding division at the fair.
- 4-H members taking a market or breeding swine project must also be enrolled in the appropriate manual based project. Their level in these projects will be determined by age and skill level.
- Feeder or market swine status of swine entry will be determined at the time of weigh-in. Swine less than 200 pounds considered feeder swine

Showmanship refer to page 132

Division 12A -Market Swine

Carter County 4-H & FFA Members Only in this Division

Class

1. Market Swine

- 4 Any other project-related item
- 5 Any other project-related item

DEPT AA Division 5 - CAT

Division 5A - Level I - Purrr-fect Pals (Points 4, 2, 1)

Class

- 1 A poster of a cat that you have drawn and labeled at least twenty body parts
- 2 A poster with pictures and descriptions of at least ten breeds of cats
- 3 Design and create a poster to find a lost cat
- 4 An educational display on cat grooming supplies and skills
- 5 Project manual
- 6 Any other project-related item

Division 5B -Level II - Climbing Up! (Points 4, 2, 1)

Class

- 1 Identify and classify at least 30 jobs or careers associated with cats
- 2 A chart comparing at least six different pet food labels
- 3 poster or educational display on prevention and control of fleas on cats
- 4 Poster of cat pictures and what you believe their body language is communicating
- 5 Poster or notebook on common feline diseases, their symptoms, their prevention and/or cure
- 6 Project manual
- 7 Any other project-related item

Division 5C -Level III - Cat Connections (Points 4, 2, 1)

Class

- 1 A complete business plan for a cat-related business. Include a business card you have designed.
- 2 A chart on dominant and recessive traits of cats
- 3 A poster of a drawing of a cat's digestive system with the parts labeled
- 4 A poster of a drawing of a cat's skeletal system with the bones labeled
- 5 A poster of the reproductive systems of a male and a female cat with the parts labeled
- 6 An educational game that you have created about cats
- 7 Project manual
- 8 Any other project-related item

DEPT KK Division 6 - CHILD DEVELOPMENT/BABYSITTING

(Points 4, 2, 1)

Judge will determine most outstanding Child Development project, which will be eligible to advance to the Champion of Champions Contest at the Eastern Montana Fair.

Division 6A -Level 1 - Growing on My Own

Class

- 1 A Bloomin' Bag
- 2 A collection of pictures of yourself at different ages. Display and describe how you have changed on the outside and the inside
- 3 A learning box with 10 or more items (labeled)
- 4 Collection of puzzles, games and music for children
- 5 A collection of story masks showing at least four different emotions
- 6 Pictorial collection of different masks (at least five) and description of the feeling the masks show
- 7 A sweet potato vine grown from your potato pal
- 8 A family picture with a list of each person's similarities and differences
- 9 Time management clock - labeled
- 10 Exhibit time out ideas and activities - notebook, poster or card index
- 11 Chart, poster or notebook listing 12 roles of your life, the responsibilities of each role and the hat you would wear
- 12 A "Me Hat" that shows your many roles
- 13 List of hazards in your home and what you have done to correct them
- 14 A list of safety rules for your own bedroom
- 15 A safe toy tube and collection of five safe and five unsafe toys for children three years old and under
- 16 List or display of at least ten food items unsafe for young children and how you would make them safe
- 17 Project manual
- 18 Any other project-related item

Division 6B -Level 2 - Growing With Others

Class

- 1 Home alone game on poster board
- 2 Home alone box
- 3 Family keys poster
- 4 A plan for when I'm alone
- 5 An emergency telephone list
- 6 Collections of 10 recipes of nutritious snacks to make safely alone
- 7 Draw a picture of problem situations for which you are responsible, List possible solutions.

4. Only members entering the Junior and Senior Division of Showmanship will be eligible to advance into the Round Robin competition.
5. Champion showman will be selected in each of the following divisions: (1) Beef Showmanship, (2) Horse Showmanship, (3) Dairy-Cattle Showmanship, (4) Dairy Goat Showmanship, (5) Swine Showmanship, and (6) Sheep Showmanship, (7) Fiber Goats.
6. Dress code required for the member's livestock project must be followed when competing in showmanship contest with that animal. All divisions require neat clothing; pants and appropriate shirts. Western hats and boots are required in the horse divisions heavy footwear is required in all other large livestock divisions. Shirts with writing, baseball caps, tennis shoes, thongs or sandals are not allowed.
7. All contestants will receive a ribbon awarded by the judge on the Danish System.
8. Round Robin contest consists of market beef, horse, dairy cow, dairy goat, market swine, and market sheep even if a grand or reserve champion is not awarded in each specie. If a specie did not qualify for Round Robin, the superintendent will choose a suitable animal of that specie.
9. A grand and reserve will be selected in both the Senior and Junior Division Round Robin contests as decided by the judges.
10. Champion showman in Junior Stocker-Feeder Showmanship contest will not advance to the Round Robin contest.
11. Dogs must be shown with proper lead and be groomed and clean.
12. The conformation of the dog is not considered, but only the ability to present the dog to the judge.
13. Dogs are to enter ring at a counter-clockwise manner, or to the right of the rail, with dog between judge and exhibitor.

Class

1. Senior Beef
2. Junior Beef
3. Novice Beef
4. Senior Horse
5. Junior Horse
6. Novice Horse
7. Senior Dairy Cattle
8. Junior Dairy Cattle
9. Novice Dairy Cattle
10. Senior Goats

	Ram 2yrs & under 4	Ram 1yr and under	Ram under 1 yr	Ewe 2 yrs & under 4	Ewe 1 yr and under 2	Ewe under 1 yr	Pen of 3 lambs	Flock
Rambouillet	1	2	3	4	5	6	7	8
Hampshire	9	10	11	12	13	14	15	16
Targhee	17	18	19	20	21	22	23	24
Columbia	25	26	27	28	29	30	31	32
Suffolk	33	34	35	36	37	38	39	40
Montdale	41	42	43	44	45	46	47	48
Crossbred				49	50	51	52	53
Other	54	55	56	57	58	59	60	61

DEPT AP DIVISION 11 - SHOWMANSHIP (Points 5, 3, 2)

- 4-H and FFA members will participate in showmanship together. All 4-H and FFA members must exhibit in the division in which they participate in the showmanship contest. All livestock members are encouraged to enter showmanship divisions.
- The contestant MUST be able and ready to prove to the judge his ability to groom and fit animals.
- Contestants will be divided into three divisions:
 - Senior Division: Members must be 14 years or age or older October 1 of current 4-H year.
 - Junior Division: Members 13 years of age or younger before October 1 of current 4-H year.
 - Novice Division: Members showing this specie for the first time who would like to take part in a learning experience designed to prepare them for future competition.
(4-H year is from Oct 1 to Sept 30)

- Coupon book of responsibilities you'll take on
- Toy chart poster
- Display of toy collection (age appropriate)
- Age level cards (at least 10) and matching toy cards
- Poster of circle of friends (Reduced size)
- A collection of friendship books
- A friendship chain
- A kite you make decorated to show how you & your friend are alike
- A collage about the most important quality of a friend
- A poem about the most important quality of a friend
- A jigsaw puzzle you made with a secret message
- A child development mural
- Design a mural for the outside wall of the exhibit hall
- Family mobile
- A 3-dimensional family tree
- A drawn family tree tracing your genealogy
- A family train
- A Family Rules poster
- A photo story of preparing and eating a family meal
- Poster of the Food Guide Pyramid
- A safe Baby's Toy Box with at least five save baby toys inside (include explanation)
- Street smart game on poster board
- Safety notebook.
- Safety poster
- Project manual
- Any other project-related item

Division 6C -Level 3 - Child Development

Class

- A career game you have created for a specific age group
- A quiz board about child development careers
- Your own resume for a career in child care
- A child development observation record sheet on two children
- A how-to guide for child care providers written by you for ages five to six
- A set of completed television evaluation forms for at least five shows aimed at kids
- Your own script for a kid's T.V. show
- Poster or notebook comparing positive and negative messages in popular kid's magazines

- 9 Poster of challenges that children with disabilities would face and how to accommodate each disability in a classroom setting.
- 10 Outline a Friendship Guidebook on how to make and be a friend
- 11 A Friendship Quilt
- 12 A community profile
- 13 A set of building blocks you have made
- 14 Pictures and description of community service project you planned and implemented with local Senior Citizens
- 15 The roles and responsibilities of parenthood determined by interviewing at least 10 parents
- 16 Journal of your experience while babysitting
- 17 Picture and explanation of a planned teaching or coaching project you have undertaken this year
- 18 Information, display, poster, or notebook on activities available to youth in your community
- 19 Puppets you have made and script for a puppet on show on discipline
- 20 Picture display and explanation of your Movin' and Shakin' Olympics
- 21 Notebook on results after evaluating local playgrounds for safety features and your plans to change unsafe areas
- 22 First aid kit and plans to make and distribute to needy families
- 23 Set of three posters illustrating basic first aid and poison control emergencies
- 24 Project manual
- 25 Any other project-related item

Division 6D – Babysitting

Class

1. Poster on a project related topic
2. Notebook which could include project related activities
3. Educational display on a project related topic
4. A Babysitter's Magic Bag
5. Any other project related exhibit

DEPT FF Division 7 - CLOTHING AND TEXTILES (Points 5, 3, 2)

Each exhibit winning best of division in Skill Level I, Level 2, and Level 3 is eligible to advance to the Champion of Champions contest at the Eastern Montana Fair.

Division 7A -Skill Level 1 - Sew and Have Fun

Class

- 1 An educational poster - Parts of the sewing machine

DEPT AP DIVISION 10 - SHEEP

Division 10A -Market Lambs (Points 7, 4, 2)

- 4-H members must be enrolled in the Market-Lamb Project to exhibit market sheep.
- Only lambs under 1 year of age may be shown.
- Lamb entry will be determined at the time of weigh-in. Lambs less than 90 pounds will be considered feeder lambs.
- Members must have possession of animals by June 1st.
- All animals must have scrapie ID tags
- Members can sell one market lamb.
- Market lambs can be all breeds - ewes or wether.
- 4-H members taking a market or breeding sheep project must also be enrolled in the appropriate manual based project. Their level in these projects will be determined by age and skill level.

Carter County 4-H & FFA Members Only in this Division

Showmanship refer to page 132

Class

1. Single market lamb
2. Single feeder lamb born during the current season
3. Pen of three market lambs (individual member or club entry)
4. Pen of three feeder lambs (individual member or club entry)

Division 10B -Breeding Sheep (Points 7, 4, 2)

- 4-H members must be enrolled in Sheep Breeding 1 or 2 to exhibit breeding sheep
- Members are encouraged to exhibit market lambs produced by his/her own breeding project animals. However, the same animal cannot be entered in both the market and the breeding divisions at the Fair.
 - Members must have possession of animals by June 1st.
 - Sheep entered in breeding class will be judged on breed type, characteristics, quality and development for age. A flock consists of one ram, two ewes and two lambs. All animals in a flock entry may also be shown as singles and must be entered so first. No wether may be shown in breeding division

Partridge	22	23	24	25	26	27	28
Quail	29	30	31	32	33	34	35
Other	36	37	38	39	40	41	42

DEPT AP DIVISION 8 - RABBITS (Points 5, 3, 2)

- Exhibitor must be present to show the animals during judging.
- Members must bring their own cages to exhibit rabbits in.
- Rabbits under 6 weeks and pregnant does will not be shown.
- Members must have possession of rabbit(s) by June 1st.
- Members may exhibit 2 entries per class if animals are different breeds. **MUST STATE BREED ON ENTRY TAG**
- Members in the Advanced Unit may sell one of their rabbits.

Showmanship refer to page 132

Division 8A- Market Rabbit (Points 5,3,2)

Carter County 4-H & FFA Members Only in this Division

Class

1. Market rabbit, less than 6 months (state breed)

Division-8B -Rabbits (Points 5, 3, 2)

Class

1. One doe, under 6 months old (State Breed)
2. One doe, 6 months to under 12 months old (State Breed)
3. One doe, over 12 months old (State Breed)
4. Doe and litter
5. One buck, under 6 months old (State Breed)
6. One buck, 6 months to under 12 months old (State Breed)
7. One buck, over 12 months old (State Breed)

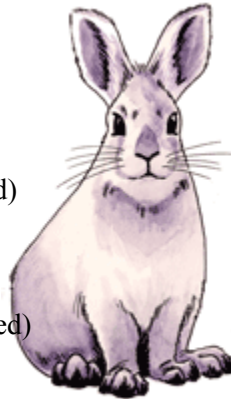

DEPT P DIVISION 9 SELF DETERMINED/INDEPENDENT STUDY (All livestock) (Points 5, 3, 2)

Each Exhibit receives a ribbon placing. Member must be present for interview during judging

Class

1. Live animal

- 2 Labeled Color Wheel Poster
- 3 Poster labeling the parts of the serger
- 4 Hand-sewn item - either mended or item you have made
- 5 Sewing box with labeled equipment
- 6 Simple stuffed toy
- 7 Potholders (2)
- 8 Sewn Pillow case
- 9 Pillow
- 10 Sleepwear
- 11 Simple Dress
- 12 Simple shorts
- 13 Simple jumper
- 14 Simple skirt
- 15 Simple vest (lined or unlined, no darts)
- 16 Simple top (sleeveless) or tank top
- 17 Simple pants
- 18 Item with some type of casing
- 19 Item utilizing hand stitching
- 20 Item with trim
- 21 Item with finished seams
- 22 Item with buttons, snaps or hooks
- 23 Educational display or notebook on laundry products and their uses
- 24 Simple serged item
- 25 Poster or display demonstrating serger stitches
- 26 Educational notebook identifying six types of fabric
- 27 Tote, book, lunch, or shopping bag
- 28 Comparison Chart - One item you've made and one item you've bought
- 29 Project manual
- 30 Any other project-related item
- 31 Any other project-related item
- 32 Stitch a card
- 33 Hair Scrunchie
- 34 Item decorated with fusible web
- 35 Tote bag

Division 7B -Skill Level II - Sew Much More

Class

- 1 Sewing-machine-maintenance chart
- 2 Fabric swatches - label type of fabric, uses and cost
- 3 Chart comparing dry cleaning costs

- 4 Jean comparison chart from at least four different sources
- 5 Crazy tote bag
- 6 Any item with clipped curves
- 7 Poster, display, or notebook of measuring tools and functions
- 8 Display, notebook, chart, or poster of textile occupations
- 9 Create and market an item - submit a business plan
- 10 Pants
- 11 Skirt
- 12 Simple dress
- 13 Pajamas
- 14 Nightgown
- 15 Blouse or tank top
- 16 Swimwear (beach robe or cover up)
- 17 Vest
- 18 Shorts
- 19 Hooded top or sweatshirt
- 20 Jumper
- 21 Pillow, decorative
- 22 Stuffed toys or dolls
- 23 Bag with zipper
- 24 Item with darts
- 25 Item that has gathers
- 26 Item with a zipper
- 27 Item with machine button holes
- 28 Item using interfacing
- 29 Item with seams finished or utilizing different i.eFlat felled French etc
- 30 Project manual
- 31 Any other project-related item
- 32 Any other project-related item
- 33 Patchwork pillow
- 34 Simple apron

Division 7C -Skill Level III - Sew On & Sew Forth

Class

- 1 Project related educational item or display
- 2 A pair of mittens you have made from 100% wool you have felted
- 3 Any item, dyed (include before picture)
- 4 A clothing item you have updated (include before picture)
- 5 Outdoor product created from polar fleece (include pattern)
- 6 Bib overall or jumpsuit

Wild, Ornamental	22	23	24	25	26	27	28
------------------	----	----	----	----	----	----	----

Division 7E -Breeding Geese (Points 5, 3, 2)

	Male less than 1 year	Male over 1 year	Female less than 1 year	Female over 1 year	Duo: 1 male 1 female	Female and brood	Half dozen eggs
Mature male weight							
Heavy 20 lbs. +	1	2	3	4	5	6	7
Medium 15-20 lbs.	8	9	10	11	12	13	14
Light under 15 lbs.	15	16	17	18	19	20	21
Wild, Ornamental	22	23	24	25	26	27	28

Division 7F -Game and Other Birds (Points 5, 3, 2)

	Male less than 1 year	Male over 1 year	Female less than 1 year	Female over 1 year	Duo: 1 male 1 female	Female and brood	Half dozen eggs
							
Guinea	1	2	3	4	5	6	7
peafowl	8	9	10	11	12	13	14
Pheasant	15	16	17	18	19	20	21

Rare and unusual	15	16	17	18	19	20	21
------------------	----	----	----	----	----	----	----

Division 7C -Breeding Turkeys (Points 5, 3, 2)

	Male less than 1 year	Male over 1 year	Female less than 1 year	Female over 1 year	Duo: 1 male 1 female	Female and brood	Half dozen eggs
Tame	1	2	3	4	5	6	7
Wild, Ornamental	8	9	10	11	12	13	14

Division 7D -Breeding Ducks (Points 5, 3, 2)

	Male less than 1 year	Male over 1 year	Female less than 1 year	Female over 1 year	Duo: 1 male 1 female	Female and brood	Half dozen eggs
Mature male weight							
Heavy 9 lbs.+	1	2	3	4	5	6	7
Medium 7-9 lbs	8	9	10	11	12	13	14
Light under 7 lbs.	15	16	17	18	19	20	21

- 7 Pants
- 8 Denim Jeans
- 9 Sweatsuit
- 10 Recreational gear: (hiking, bicycling, golfing) - For example; tent, sleeping bag, back pack or other recreational gear
- 11 Western wear: pants, jacket, shirt, coat or other western wear
- 12 Ski or snowmobile wear: jacket or 1-piece snowsuit (down or synthetic insulation), vest (down or synthetic), pants, mittens or hat, or any other ski or winter wear
- 13 Sweatshirt
- 14 Swimwear: swimsuit, cover-up, beach bag or any other swimwear
- 15 Vests (lined or reversible)
- 16 Jacket, unlined
- 17 Coat, unlined
- 18 Dress or jumper
- 19 Dress for special occasion
- 20 3-or-more-piece ensemble with one garment purchased and the rest home sewn Include price and care labels for purchased garment
- 21 Blouse with set-in sleeves
- 22 Striped or plaid garment
- 23 Skirt, pant skirt or culotte
- 24 Sleepwear (pajamas or nightgown)
- 25 Robe or housecoat
- 26 Lined garment
- 27 Garment for another person, include picture
- 28 Man's or boy's shorts
- 29 Item including interfacing
- 30 Item with pockets
- 31 Item with collar and/or cuffs
- 32 Top-stitched item
- 33 Accessory
- 34 Project manual
- 35 Any other project-related item
- 36 Any other project-related item

Division 6D Skill level IV Advanced

Class

1. Project related educational item, display poster or notebook
2. An original design created for yourself or someone else
3. An item with lining
4. An item or garment using interfacing in shaping

5. A formal or tailored garment
6. An item that masters bound button holes
7. An item with interfaced hem
8. An item with creative uses of embellishments
9. An item demonstrating expertise in working with at least two challenging fabrics
10. New garment made from recycled garment include before and after pictures
11. Any other project related item
12. Any other project related item

**DEPT KK Division 8 - CLOVERBUDS (4 Points)
(Only blue ribbons given)**

Exhibits must be related to information in Cloverbud Manual Class

- 1 Animals - Pets
- 2 Creative Arts
- 3 Clothing Fabric
- 4 Environmental education
- 5 Food and nutrition
- 6 Games
- 7 Horticulture education
- 8 Health and Safety
- 9 Performing arts
- 10 Recipes
- 11 Science
- 12 Any other project related item

DEPT KK Division 9 - CROP SCIENCE (Points 4, 2, 1)

Division 9A -Wheat-Grower Helper

Class

- 1 Display showing how to run germination tests
- 2 Display showing wheat at different stages of growth
- 3 Notebook, poster or display on some other aspect of your project
- 4 Project manual
- 5 Any other project-related item

Division 9B -Junior Wheat Grower

Class

- 1 Poster or display on soil sampling and fertilization

DEPT AP DIVISION 7 – POULTRY

Members must have possession of poultry by June 1st. Members may exhibit two entries per class if animals are different breeds. **Must state breed on entry tag.**

- Exhibitor must be present to show their poultry during judging.
- Market poultry should be 8 weeks old or at least 4 lbs. and must be under 1 year. Each member may sell one (1) market poultry
- Eggs must be produced by a female that is entered in the fair

List of Chicken breeds and classifications

Rare and unusual: All Bantams turken, all Crested and all Cochin, Langshan, all rare and unusual breeds

Dual purpose: Wyandottes, Orpington, Rock, New Hampshire, Giants, Sussex, Cornish, Brahms and Delaware.

Egg Type: Astralorp, Rhode Island Red, Araucana/Americana, Red Star ,Black star. all white egg laying chickens.

Showmanship refer to page 132

Division 7A -Market Poultry (Points 5, 3, 2)

Carter County 4-H & FFA Members Only in this Division

Class

1. Poultry under 1 year (state type on entry form)

Division 7B -Breeding Chickens (Points 5, 3, 2)

	Male less than 1 year	Pullet less than 1 year	Male over 1 year	Hen over 1 year	Duo: 1 male 1 female	Hen and brood	half dozen eggs
Egg type	1	2	3	4	5	6	7
Dual purpose	8	9	10	11	12	13	14

- Cut and drive selected cows or pairs
- Work in a corral roping and/or sorting calves
- Any task from Level I, II, & III

Division 6S -Horse Judging (Points 4, 2, 1)

Class

1. Notebook with plans, records, pictures, reports etc., pertaining to project requirements. Be available for interview.

Division 6T -Horse Showing (Points 4, 2, 1)

Class

1. Notebook with plans, records, pictures, reports etc., pertaining to project requirements. Be available for interview.

Division 6U -Careers with Horses (Points 4, 2, 1)

Class

1. Notebook with plans, records, pictures, reports etc., pertaining to project requirements. Be available for interview.

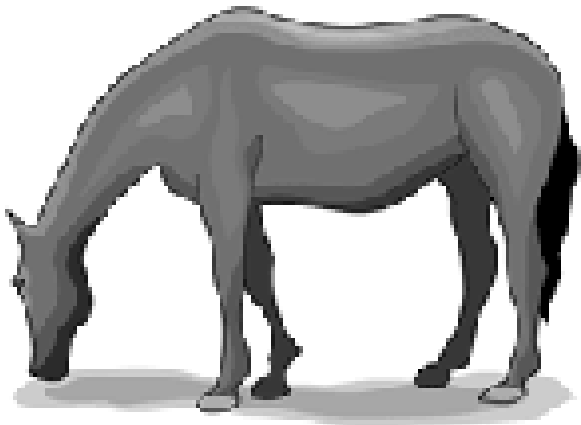

2. Poster, notebook or display on wheat varieties
3. Poster, notebook or display on weeds, diseases or insects that affect wheat
4. Poster, notebook or display on some other aspect of your project
5. One quart sample of threshed wheat
6. Project manual
7. Any other project-related item

Division 9C -Senior Wheat Grower

Class

1. Notebook on your wheat production enterprises (up to where you are at). Include all production inputs and their costs. You may include an estimate of harvest costs, yields, and values, if you like; but use actual yields and costs for final records.
2. Poster or display on wheat storage
3. Poster or display on wheat marketing
4. Poster, notebook or display on some other aspect of your project
5. Project manual
6. Any other project-related item

Division 9D -Practical Crop Production

Class

1. Notebook on your production methods and costs
2. Educational poster or display on some aspect of your crop, such as production, storage, marketing, etc
3. Samples of your crop at different stages of growth
4. Project manual
5. Any other project-related item

Division 9E -Barley-Grower's Helper

Class

1. Photo story of barley germination test
2. Collection of barley plants at different stages of growth (follow project book)
3. Notebook on project showing 20 hours of work in barley project. Include the following: seedbed preparation, planting, harvest, record of yields, and number of acres harvested daily.
4. Poster or display related to project
5. Project manual
6. Any other project-related item

Division 9F -Junior Barley Grower

Class

- 1 Photo story of five varieties of barley as outlined on page 6, activity 2, of project book
- 2 Notebook on weed, disease, or insect that threatens barley. Explain problem, characteristics, losses and method of control. (See activity 2C, page 6, in project book) Include photos and samples
- 3 One quart sample of threshed barley from project
- 4 Poster or display related to project
- 5 Notebook on project that records all phases of your barley project. Include photos and samples.
- 6 Project manual
- 7 Any other project-related item

Division 9G -Senior Barley Grower

Class

- 1 Rental agreement made to grow either 30 or more acres of barley or 5-10 acres of certified seed barley. (see project book, page 7, activity 1, for complete details)
- 2 Complete project records with photo story and one quart of threshed barley from your project
- 3 Printout of computer program (page 8, activity 4e, in project book)
- 4 Two food items utilizing barley flour
- 5 Poster or display related to project
- 6 Project manual
- 7 Any other project related item

DEPT AA Division 10 - DAIRY COW (Points 4, 2, 1)

Division 10A -Dairy 1 - Dig into Dairy

Class

- 1 collection of pictures and information on the six different dairy breeds
- 2 Poster with your drawing of a dairy cow with at least 20 body parts labeled
- 3 Poster or educational display on products and by-products that come from a dairy cow
- 4 A chart comparing the nutrients in milk and soda pop
- 5 Poster of pictures used to show how milk will help market this product
- 6 Your own milk carton design that will help market this product
- 7 Poster of the steps in the birth process and care of newborn calf

Class

- 2 Level II
 - Cross logs
 - Move through brush
 - Demonstrate riding on steep hills, side hills, bogs, muddy areas, etc.
 - Execute side pass and/or explain uses on a ranch
 - Execute simple lead change and explain importance of recognizing leads
 - Ride quietly through a herd of cows
 - Slowly move a herd of cows, stop and hold them in place
 - Open, pass through and close a hinged gate while mounted
 - Identify different brands and explain why needed
 - Conditioning your horse:
 - To a rope - twirl it nearby and/or drag near legs and feet, over back
 - To a slicker
 - Demonstrate roping skills from the ground - rope heeling dummy, moving targets, etc.
 - Any task from Level I

Class

- 3 Level III
 - Execute a rollback on a fence
 - Execute a rollback away from fences
 - Explain importance of above maneuvers on a ranch
 - Back horse through an obstacle and in a circle
 - Safely lead another horse from your horse
 - Execute flying change of leads and/or explain importance
 - Hold a cattle herd while someone works cows from it
 - Put on and take off slicker while mounted
 - Demonstrate reading brands and brand location
 - Rope off your horse at a stationary object
 - Any task from Level I & II

Class

- 4 Level IV
 - Demonstrate giving a horse a shot
 - Demonstrate ear tagging cattle
 - Demonstrate how to hobble a horse
 - Demonstrate how to make an emergency set of hobbles
 - Execute all maneuvers in a working-cow-horse pattern

Class

3 Three-year-old

- To be driven pulling a stone boat, or tow or four wheel vehicle.
- Chariots will not be allowed.
- Simple maneuvers will be required.
- Be able to exhibit basic knowledge of parts of the harness and hitch.

Class

4 Four-year-old

- To be hitched and re-hitched in arena - head man required.
- Must follow simple pattern.
- May be driven as a team with an older broke horse but not mandatory.

Class

5 Five-year-old

- Horse to be harnessed before judge in safe, enclosed area.
- Must follow an advanced pattern with precision driving skills.
- May be driven as a team with an older broke horse but not mandatory.

Division 6R -Ranch Horse Class (Points 7, 4, 2)

- This class will be judged on performance of horse and rider. Following equipment will be required when competing in the class: saddle, bridle, saddle pad, saddle bag, rope and hobbles.
- The judge may ask contestant to describe the care of equipment, basic nutrition or basic facilities for a horse. Competition will consist of at least six skills selected from the following lists:

Class

1 Level I

- Mount and dismount safely
- Walk to lope to walk
- Stop from walk, trot and/or lope
- Recognize leads
- Cross a bridge
- Walk your horse through water
- Back in a straight line
- Lope in a circle to demonstrate “handle”
- Open, walk through and close gate properly while leading your horse
- Lead your horse safely beside and behind you
- Demonstrate roping on the ground
- Demonstrate different roping techniques - heading/healing

8 A poster of all the dairy or dairy related products you can find in a store you visit List products with/without pictures

9 Project manual

10 Any other project-related item

Division 10B -Dairy 2 - Mooving Ahead

Class

- 1 Poster of a comparison chart of a dairy cow to a wild animal
- 2 Information on different dairy organizations you have researched and/or written to
- 3 Poster or notebook with imported dairy products available in your area. Include pictures and country of origin or wrappers
- 4 A new package you have designed for a dairy product
- 5 A new technology time line of the dairy industry
- 6 A poster of at least 30 jobs or careers that are involved in bringing milk to your dinner table. Include categories such as production, processing, etc.
- 7 A cost comparison for dairy production in different regions of the country
- 8 A collection of samples of different feeds or supplements for each of the nutrients a dairy cow requires
- 9 Project manual
- 10 Any other project-related item

Division 10C -Dairy 3 - Leading the Way

Class

- 1 The results of a dairy food survey you have designed and conducted
- 2 Pictures or drawings of various aspects of dairy farming. Include location of each farm and have at least one local
- 3 Pictures and explanation of an activity you planned, promoted, and implemented to help others learn about dairy animals
- 4 Project manual
- 5 Any other project-related item

DEPT AA Division 11 DAIRY RELATED PROJECT (points 5, 3, 2)

Must be enter enrolled in live animal project to enter this class

Class

- 1 1 pint whole milk (goat)
- 2 1 cup fresh cream (goat)
- 3 ½ cup unsalted uncolored butter (goat)
- 4 1 quart whole milk (dairy cow)
- 5 1 pint fresh cream (dairy cow)

- 6 2 cups unsalted ,uncolored butter (dairy cow)
- 7 Any other project related item

DEPT AA Division 12 – DOG (Points 4, 2, 1)
Division 12A -Level 1 - Wiggles and Wags

Class

- 1 A poster with a picture or drawing of a dog you own or would like to own Include a description of animal.
- 2 Poster of pictures and descriptions of different dogs and how they help people
- 3 A poster of labeled pictures of at least 20 different breeds of dogs
- 4 A poster of a drawing of a dog with the dog's body parts labeled
- 5 An educational display on dog grooming supplies and skills
- 6 Project manual
- 7 Any other project-related item

Division 12B -Level 2 - Bounding Ahead

Class

- 1 Poster or notebook on ten different breeds of dogs. Include picture, description, name of dog group, and country of origin.
- 2 A chart describing the training or precautions to avoid at least ten nuisance dog behaviors
- 3 A chart comparing three different brands of dry dog food. Include a basic brand, a moderately priced brand and the most expensive brand.
- 4 A chart listing advantages and disadvantages of at least six different sources to get a dog
- 5 A poster with a description of different canine diseases, their prevention, and treatment
- 6 Recipe and example of homemade dog biscuits (plate of six)
- 7 Poster with at least six photographs you have taken of your dog that tells a story
- 8 Poster describing at least ten dog-related careers
- 9 A lost dog poster of your own dog or a friend's dog that you have planned, designed and created
- 10 Project manual
- 11 Any other project-related item

Division 12C -Level 3 - Pointing the Way

Class

- 1 A complete budget showing how much it costs to own a dog for one year. Identify as a small, medium, or large dog

Level II - Driving

- Horse(s) are hitched to a cart.
- Walk, jog, trot, road gait both ways of ring. Reverse and stand.
- Obstacle driving: Mandatory - back through L-shaped poles, row of pylons.
- Optional: Bridge, mailbox, pivot with-in circle.

Class

- 3 Single harness
- 4 Double harness

Level III - Driving

- Same as Level I Precision driving using obstacle course(timed event)

Class

- 5 Single harness
- 6 Double harness

Level IV - Driving (Points 4, 2, 1)

Class

- 7 Notebook with plans, records, pictures, reports etc., pertaining to project requirements. Be available for interview.

Dept A5P Division 6Q -Draft or Light Horse Training (Points 7, 4, 2)

- Members must be 12 years of age or older during the current 4-H year and have completed two levels of Driving before taking the Draft or Light Horse Training Project.
- A Training Project horse cannot be used in the Driving Project.

Class

- 1 Yearling
- Will compete with yearlings in the Training a Colt to Maturity.

Class

- 2 Two-year-old
- Be able to exhibit basic knowledge of parts of the harness and hitch.
- To be driven either in breaking harness or full harness.
- To be driven in a full circle both directions.
- Stop and back.

- Back through "L" shaped course at least 30 in. in width or back a triangle pattern through three oil drums.

Optional Obstacles:

- Ride over at least four (4) logs
- Water Hazard
- Walk over animal hide
- Walk over single pole (obstacles not more 24 in. high)
- Carry object from one part of arena to another (only objects which reasonably might be carried on a trail ride may be used)
- Put on and remove slicker
- Dismount and lead horse over obstacles not less than 12 in. high or over 18 in. in height
- Remove and replace material from mailbox
- Side pass
- Obstacle consisting of four logs or rails each 5 to 6 feet long, laid in a square
- Each contestant will enter the square by stepping over the log or rail at the designated side. When all four feet are inside the square, the rider will execute a 360° turn (right or left), pause and depart by stepping over the log or rail immediately opposite the side of the entry
- Ground tying (dismount, walk about 10 to 15 feet and return and mount; also to be judged on dismounting and mounting)
- Rail work at the discretion of the judge
- NO bales of hay or straw will be used in a trail class because of the danger of catching feet or shoes in string or wire.
- NO tires will be used in trail class because of the danger of catching feet in tires.
- While horse is in motion, rider's hands shall be clear of horse to avoid cuing. Horses to be penalized by an unnecessary delay while approaching obstacle. Judges are encouraged to advance on to the next obstacle any horse taking excessive time at an obstacle.

Dept P Division 6P -Driving (Points 7, 4, 2)

Level I - Driving

- Ground driving only with no cart. Walk, jog, trot both ways of ring. Reverse (half of figure 8), back and stand properly.

Class

1. Single harness
2. Double harness

- 2 A copy of an article you have written and had published about the seriousness of cruelty to animals and what can be done
- 3 A poster of a dog food package you have designed to attract buyers.
- 4 Identify and describe five diseases that humans can get from dogs and include how they are transmitted.
- 5 Project manual
- 6 Any other project-related item

DEPT JJ Division 13 – ELECTRICITY (Points 4, 2, 1)

The Grand Champion Electricity exhibit is eligible to advance to the Champion of Champions Contest at the Eastern Montana Fair.

Division 13A -Level I - Magic of Electricity

Class

- 1 Home made flashlight
- 2 Simple switch
- 3 An open and a closed circuit
- 4 A conductor/insulator tester with at least 5 examples of conductors
- 5 Series circuit
- 6 Parallel circuit
- 7 A compass
- 8 An electromagnet
- 9 A galvanometer
- 10 A simple electric motor using project manual plans
- 11 Project manual
- 12 Any other project-related item

Division 13B -Level II - Investigating Electricity

Class

- 1 Poster explaining Ohm's Law
- 2 Poster ranking at least 10 conductors and 10 insulators from your own experiments
- 3 Poster of a circuit diagram with full explanations of symbols
- 4 Series circuit with the voltages measured and recorded
- 5 Parallel circuit with the voltages measured and recorded
- 6 A momentary switch for communicating a Morse Code chart
- 7 A three-way switch
- 8 A rocket launcher using project manual plans
- 9 A burglar alarm using project manual plans
- 10 Project manual
- 11 Any other project-related item

Division 13C -Level III - Wired for Power

Class

- 1 Basic electrical tool and supply kit
- 2 Notebook or paper on local and state electrical codes
- 3 Display and explanation of wires and cables, their sizes and uses
- 4 Present in form of your choice the operating cost of four different appliances for a single use and for a year
- 5 Draw a plan of your home wiring system and amount of wattage on circuits
- 6 Display and explanation of different receptacles
- 7 Display and explanation of different switches
- 8 Project manual
- 9 Any other project-related item

Division 13D -Level IV - Entering Electronics

Class

- 1 Notebook with picture, symbols and explanation of at least 20 different electronic parts
- 2 A circuit with a diode
- 3 A circuit using a transistor
- 4 Poster explaining the different characteristics of at least six transistors
- 5 A battery circuit with an LED included
- 6 Combination of a transistor, and LED and other components to form a circuit that intermittently flashed the LED
- 7 Build light sensitive semiconductor in a control circuit
- 8 Build a circuit that gives a meter reading in response to light
- 9 An SCR (Silicone Controlled Rectifier intruder alarm)
- 10 A 6-8 watt amplifier to power a speaker
- 11 Project manual
- 12 Any other project-related item

DEPT JJ Division 14 – ENTOMOLOGY (Points 4, 2, 1)

The Grand Champion Entomology exhibit will be eligible to advance to the Champion of Champions Contest at the Eastern Montana Fair. Exhibit will be judged on the following: Correctness of identification, variety of insects in collection, correctness and uniformity of pinning and labeling, condition of specimen, neatness and arrangement in the display box. Notebooks will be judged on completeness.

Division 14A -Level 1 - Creepy Crawlies

Class

- 1 Poster labeling the body parts of one or more different insects
- 2 A pitfall trap

Division 6N -Bareback Equitation (Points 7,4, 2)

- Riders will be judged on seat, feet, hands, ability to control the horse and the suitability of the horse to the rider. Performance of the horse is not to be considered more important than the method used by the rider to obtain them. NO chaps allowed.
- Members will be judged at a walk, trot and canter both ways of the ring. One or all contestants may be asked to:
 - Back
 - Name the parts of the horse and/or tack
 - Individual pattern at discretion of the judge
 - Dismount and mount

Class

1. Senior Division 14 and Over
2. Junior Division 9 - 13 Years

Division 6O -Trail Classes (Points 7, 4, 2)

- The trail class will be judged separate from the other classes. Only 4-H members in Horse Projects may enter. This class will be judged on the performance of the horse in maneuvering the obstacles. The horse should work with a reasonably loose rein without undue restraint. The judge will have the right to ask for rail work.
- Six obstacles will be used, of which three will be mandatory and three others selected from an approved list. The distance between obstacles shall be at the discretion of the judge.
- Props may be changed due to availability.

Class

1. Senior Division - 14 & over
2. Junior Division - 9 - 13 years
3. Yearling

Mandatory Obstacles:

- Opening, passing through and closing gate. (Use a gate which will not endanger horse or rider; gate constructed with a minimum of 50 in. from the top of gate to the ground and minimum width of 4 ft.)
- Ride over a wooden bridge. (Bridge should be of sturdy construction with a minimum width of 36 in. and with non-slip ramp approach.)

Division 6M -Horse Seat Equitation Over Fences

- Rules are: Hard hats with leather-type chin straps are mandatory during jumping events and practices. Riders must wear headgear passing the AHSA standards. Horse must be four-years old or older. Member must be enrolled in English Horsemanship III or English Training - five-year-old horse to enter hunt seat over fences.
- These are major faults and may be cause for elimination: A refusal, loss of stirrup, or trotting while on course when not part of the test.

Class

- Junior Hunt Seat Equitation over Fences
 - Riders 13 years old and under.--Judged on horse's performance and ability to carry a rider in the hunt field. Jumps not to exceed 2' 3".

Class

- Senior Hunt Seat Equitation Over Fences
 - Riders 14 years and older. Jumps not to exceed 2' 6".
 - Judged same as Junior Hunt Seat.

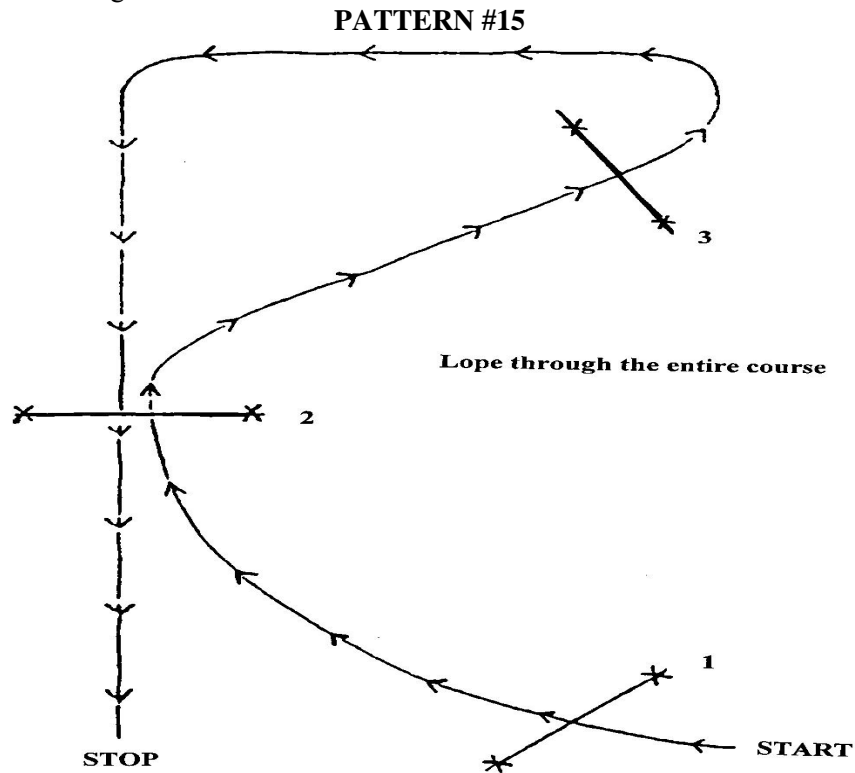

- Poster of different antennae types and pictures of example insects
- Poster of different types of insect communications and pictures of example insects
- Poster on the digestive system of a grasshopper
- Poster of different insect leg types and pictures of example insects
- Make a collecting net
- Make a killing jar
- Make a spreading board
- Make a pinning block
- Collection of at least 10 different adult insects (1st yr of level 1)
- Collection of at least 20 different adult insects (2nd yr of level 1)
- Notebook of complete records
- Project manual
- Any other project-related item

Division 14B -What's Bugging You?

Class

- Create two product containers using insects on the labels
- Poster comparing insects to their surroundings for camouflage
- Survey results of insect pests found around your home
- Paper or notebook on careers in Entomology
- Poster of complete and incomplete metamorphosis
- An extractor trap and list of dates and insect types caught
- Poster comparing different insect control chemicals
- Collection of 40 different adult insects (1st year of level 2)
- Collection of 50 different adult insects 2nd year of level 2)
- Collection of 60 different adult insects (3rd year of level 2)
- Project manual
- Any other project related item

Division 14C -Dragons, House and Other Flies

Class

- Notebook with results of study on rearing mealworms with different amounts of food
- Your own ant farm
- Notebook on results of your experiment on manipulating bee behavior
- Poster of a key to insects that others could use
- Notebook & pictures butterfly garden you planted & butterflies attracted
- Find and prepare a spider's web for display

- 7 Collect and mount stages of an insect that goes through complete metamorphosis
- 8 Poster comparing and labeling at least 10 wings from different insect species
- 9 A collection of 70 different adult insects (1st year of level 3)
- 10 A collection of 80 different adult insects (2nd year of level 3)
- 11 A collection of 90 different adult insects (3rd year of level 3)
- 12 Project manual
- 13 Any other project-related item

DEPT KK Division 15 - EXPLORING 4-H (Points 4, 2, 1)

All entries must be made by the exhibitor. Animals exhibited in Exploring 4-H will not be eligible to be sold during the Fair Livestock Sale.

Judge will determine the most outstanding Exhibit which will be eligible to advance to the Champion of Champions Contest Eastern Montana Fair.

Division 15A -Unit 1 - Discovering 4-H

Class

- 1 Montana information
- 2 Poster or notebook on Family Fun
- 3 Safety poster or display
- 4 Sew on a button
- 5 Snack recipe and picture of food item
- 6 Food pyramid guide poster
- 7 Energy poster or display
- 8 Plant or flowers or vegetable grown by member or leaf collection
- 9 Collection of ten insects—identify with common name
- 10 Bird feeder
- 11 Poster of wildlife animal tracks or bird eggs
- 12 Poster or notebook of animals and pets
- 13 Demonstration poster
- 14 Live animal (Notify Extension Office the type of animal bringing)
- 15 Project manual
- 16 Any other project-related item
- 17 Display your treasure box
- 18 Display your Travel Log
- 19 Your scrapbook of 4-H information
- 20 Display your cards and your Happy Face or Favorite things to do lists

Class

- 4 Five-Year-Old Under Saddle - English
 - Judged on ability to quietly and accurately perform pattern # 14.

PATTERN #14

1. Sitting trot
2. Halt turn on the haunches left 180°
3. Sitting trot
4. Halt turn on the haunches right 180°
5. Posting trot
6. Canter left lead
7. Flying change
8. Flying change
9. Flying change
10. Halt
11. Turn on forehand 180° (either direction), settle 5 seconds - move off at sitting trot
12. Halt, rein back 10 feet

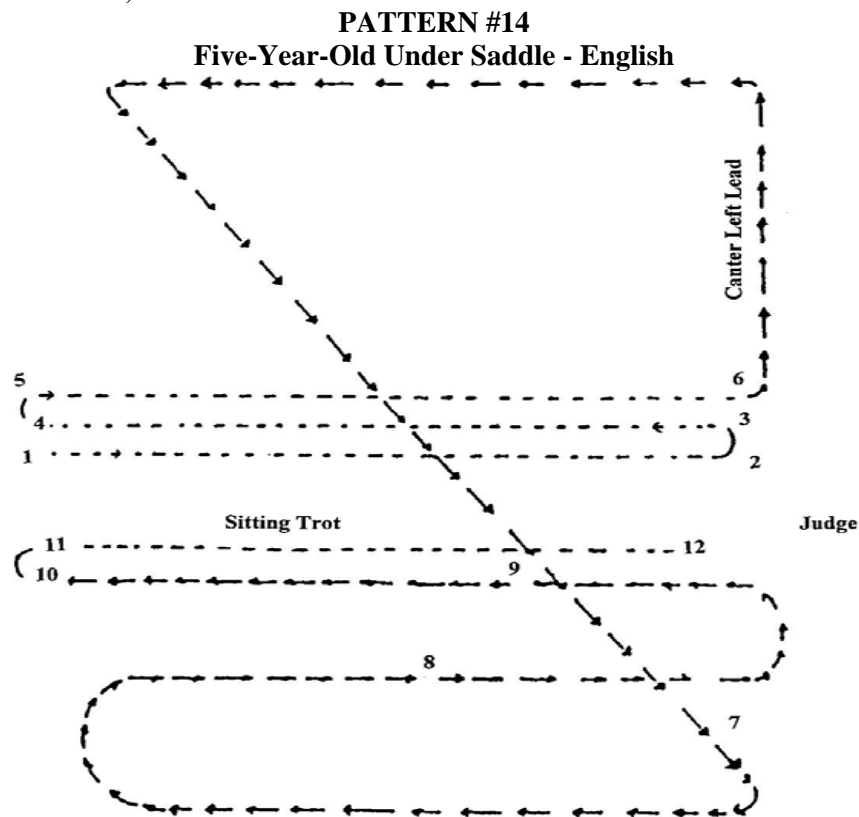

Class

3 Four-Year-Old Under Saddle - English

- Same as three-year-old class. Must perform Pattern #13.

PATTERN #13

1. Sit trot
2. Side pass right 30° angle to fence
3. Rising trot
4. Halt turn on the haunches 180° right
5. Sit trot
6. Side pass left 30° angle to fence
7. Posting trot
8. Post extended trot
9. Sit two strides; canter left lead
10. Drop to trot change lead
11. Halt - settle for 5 seconds, canter left lead
12. Halt - settle for 5 seconds, canter right lead
13. Simple change
14. Halt turn on haunch 180° right - 180° left
15. Settle horse 3 seconds and back 10 feet
16. Retire to judge

PATTERN#13

Four-Year-Old Under Saddle - English

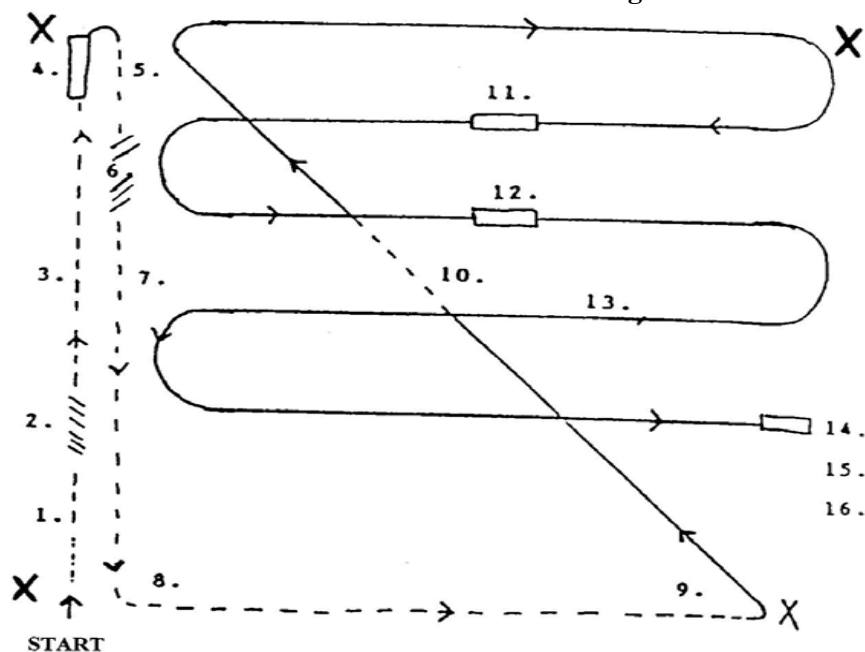

DEPT FF Division 16 - FAMILY ADVENTURES (Points 4, 2, 1)

Any valuable items - make arrangements prior to fair to be judged and to take home following judging.

Division 16A - Family Adventures

Class

1. Poster on a project related topic
2. Notebook which could include project related activities
3. Educational display on a project related topic
4. Project Manual
5. Any other project related exhibit
6. Any other project related item

DEPT HH Division 17 - FOOD AND NUTRITION

- Members are encouraged to exhibit in their project area and in "Odds and Ends" food classes. Only one entry is allowed in each class per exhibitor. Each 4-H member must make their own entries. Members of the same family should make different recipes. No packaged mixes may be used except as specified. Posters should be 14" X 22".
- Guides for display: Staple or tape entry tags on the outside of zip-lock bags. Write member's age and year in project on entry tag.
- All baked goods must be placed in clear-plastic bags. All fruit and vegetables must be displayed on Styrofoam-meat trays.
- Small paper plates are to be used whenever possible
- Salads, dressings, butter, cheese, etc., can be exhibited in clear-glass jars.
- In the event that room to display items is limited. A portion of each exhibit will be put on display and remaining may be picked up by exhibitor anytime before 12:00 p.m. on Friday, any remaining items at that time may be given to the public.

Division 17A -Beginning Foods

Class

- 1 Display of measuring tools
- 2 Poster on food groups
- 3 Recipe file with at least 10 recipes from this area
- 4 Peanut Butter Oatmeal cookies (4)
- 5 Gingerbread, ½ of cake on large meat tray
- 6 Monkey Bread, ½ of ring on large meat tray
- 7 Veggie bites (1 cup)
- 8 Project manual
- 9 Any other project-related item

Division 17B -Six Easy Bites

Class

- 1 Recipe file with at least 10 recipes
- 2 Granola bars (4) (include recipe)
- 3 Shaped or molded cookies (4) (include recipe)
- 4 Bar cookies (4) (include recipe)
- 5 Drop cookies (4) (include recipe)
- 6 Icebox or refrigerator cookies (4) (include recipe)
- 7 Colossal Chocolate Chunk Cookies (2) (include recipe)
- 8 Mystery Muffins (4) (include recipe)
- 9 Any muffin (4) (include recipe)
- 10 Quick bread loaf (include recipe)
- 11 Frozen cookies displayed in freeze bag or freezer container (6)
- 12 Frozen berries displayed in freezer bag or freezer container
- 13 Project manual
- 14 Any other project-related item

Division 17C -Tasty Tidbits

Class

- 1 Recipe file with at least 20 recipes
- 2 Educational display on how to freeze vegetables
- 3 Melon Boat fruit salad
- 4 Hot cocoa mix in storage container (include recipe)
- 5 Square, oblong or round layer of cake without frosting (include recipe)
- 6 No yeast Twisty Pretzels (4) (include recipe)
- 7 Rolled baking powder biscuits (4) (include recipe)
- 8 Dried banana chips in plastic bag or container
- 9 Frozen un-baked drop cookies in freezer bag or freezer container
- 10 Project manual
- 11 Any other project-related item

Division 17D -You're the Chef

Class

- 1 Recipe file with at least 30 recipes
- 2 Educational report on anorexia and bulimia
- 3 3/4 loaf of banana bread (include recipe)
- 4 3/4 loaf of yeast bread (include recipe)
- 5 Bread sticks (4) (include recipe)
- 6 Yeast rolls of any shape but not a sweet roll (4) (include recipe)

PATTERN #12
Three-Year-Old Under Saddle - English

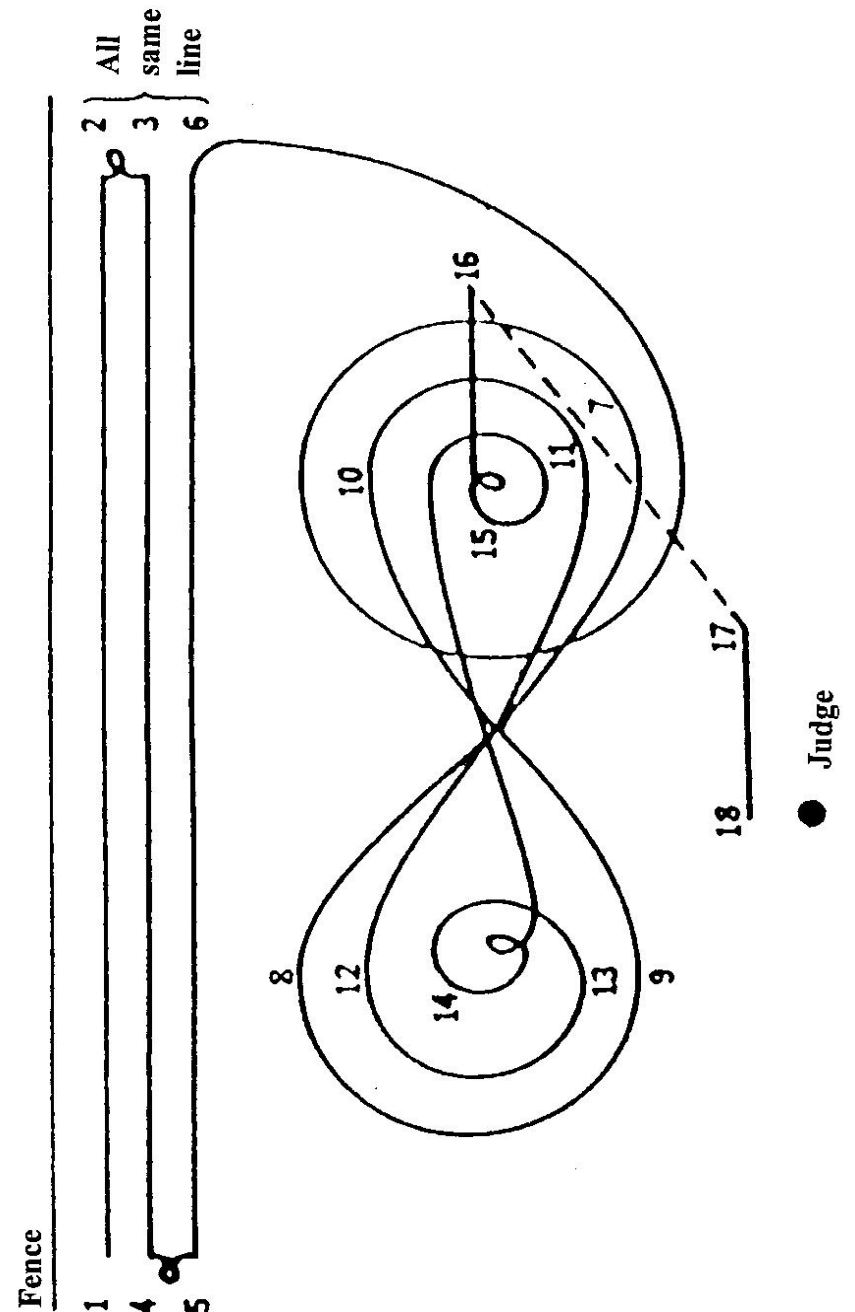

Division 6L Horse Training: English

Class

1 Two-Year-Old Under Saddle - English

- Open only to two-year-old fillies and geldings. Animal will show with a D or O ring snaffle. The use of a running martingale is permissible, not mandatory. Horses will be direct reined only. Horses will be judged at walk, trot and canter. Other tasks may be asked to do: halt from walk, dismount and mount, unsaddle and saddle up, back while dismounted, name parts of animal, equipment and nutrition.

Class

2 Three-Year-Old

- Same as two year. Rider will have horse lengthen and reduce gaits as directed by judge. Must perform Pattern #12. Other tasks: Same as two year old and identify leads.

PATTERN #12

Retire to one end of the arena where each rider will perform the following pattern individually:

- 1-2. Trot along side of fence about 100 feet
2. Stop
- 2-3. Turn on forehand (front pivot foot to stay in 2 foot circle) with hindquarter moving to the right
- 3-4. Trot back toward starting point along the fence
4. Stop
- 4-5. Turn on the forehand (front pivot foot to stay in 2 foot circle) with hindquarter moving to the left
- 5-6. Trot along fence striking into a right lead as the rider begins the Figure 8 and go around Circle A once at the canter
7. Drop to a trot
8. Pick up a left lead and go around Circle B at the canter
9. Drop to a trot
10. Pick up right lead and go around Circle A at the canter
11. Drop to a trot
12. Pick up left lead and go around Circle B at the canter
- 13-14. Trot a small circle to the left
- 14-15. Trot a small circle to the right
- 15-16. Trot
16. Stop
- 16-17. Back 10 feet
17. Stop, settle horse for 10 seconds
18. Retire to judge for inspection

- 7 One jar of a canned tomato product using Hot Pack method (include recipe and complete instructions)
- 8 Fruit leather (include recipe)
- 9 One container of freezer jam (include recipe and storing instructions)
- 10 One jar of fresh pack dill pickles (include recipe and complete instructions)
- 11 Package non-perishable invented snack. Exhibit must include a separate folder containing a marketing plan with product name, recipe, how it will be packaged, package design, where it will be sold and suggested selling price.
- 12 Project manual
- 13 Any other project-related item

Division 17E -Food works

Class

- 1 Recipe file with at least 40 recipes
- 2 Educational report on changes in nutritional needs from youth to adult to senior citizens
- 3 Plan a catered party from start to finish and outline every detail in a written and visual report
- 4 One double-crust fruit pie (include recipe)
- 5 One jar of pressure canned vegetables
- 6 One jar of pressure canned meat or combination product
- 7 One jar of jelly without added pectin (include recipe and instructions)
- 8 Beef jerky (include recipe)
- 9 Peanut butter from recipe in Project Manual
- 10 Project manual
- 11 Any other project-related item

Division 17F – Up for the Challenge, Healthy Decisions

Class

1. Chart of daily activity for one week
2. Chart of drink consumption for 2 days
3. Chart of Label Lingo
4. Charts of Whoa, Slow and Go Snack Foods
5. Chart of Steps
6. Chart of Screen Time
7. Project Manual
8. Any other project related exhibit

Division 17G –Fast Foods

Class

1. Notebook which could include project related activities
2. Education display on a project related topic
3. Any project related display or poster
4. Any project related food item
5. Any other project related item
6. Any other project related item

Division 17H -Quick Meals (Points 4, 2, 1)

Class

1. Spicy granola cereal (1 cup)
2. Breakfast bars (4)
3. Oatmeal-applesauce cookies (4)
4. Microwave cheese sauce (1 cup)
5. Collection of recipes for main dishes
6. Consumer display
7. Display or poster on nutrition
8. Project manual
9. Any other project-related item

DIVISION 17I- Cooking 101

Class

1. 1 cup hot cocoa mix in container
2. 3 cereal bars, granola bars or no bake cookies
3. 1 cup snack mix
4. 3 muffins, from scratch, no paper liners
5. 1 8 x 8 pan cornbread from scratch
6. 3 drop biscuits from biscuits
7. 1 8 x 8 pan coffeecake, fruit jumble or fruit crisp
8. 3 brownies made from scratch
9. 3 cookies (from pages. 68-71 of manual)
10. 1 8 x 8 cake made from scratch
11. Any other project related item

DIVISION 17J- Cooking 201

Class

1. 1 loaf nut bread
2. 3 cheese muffins from scratch, on paper liners
3. 3 rolled biscuits from scratch
4. 2 scones from scratch

PATTERN #11 English Horsemanship VI

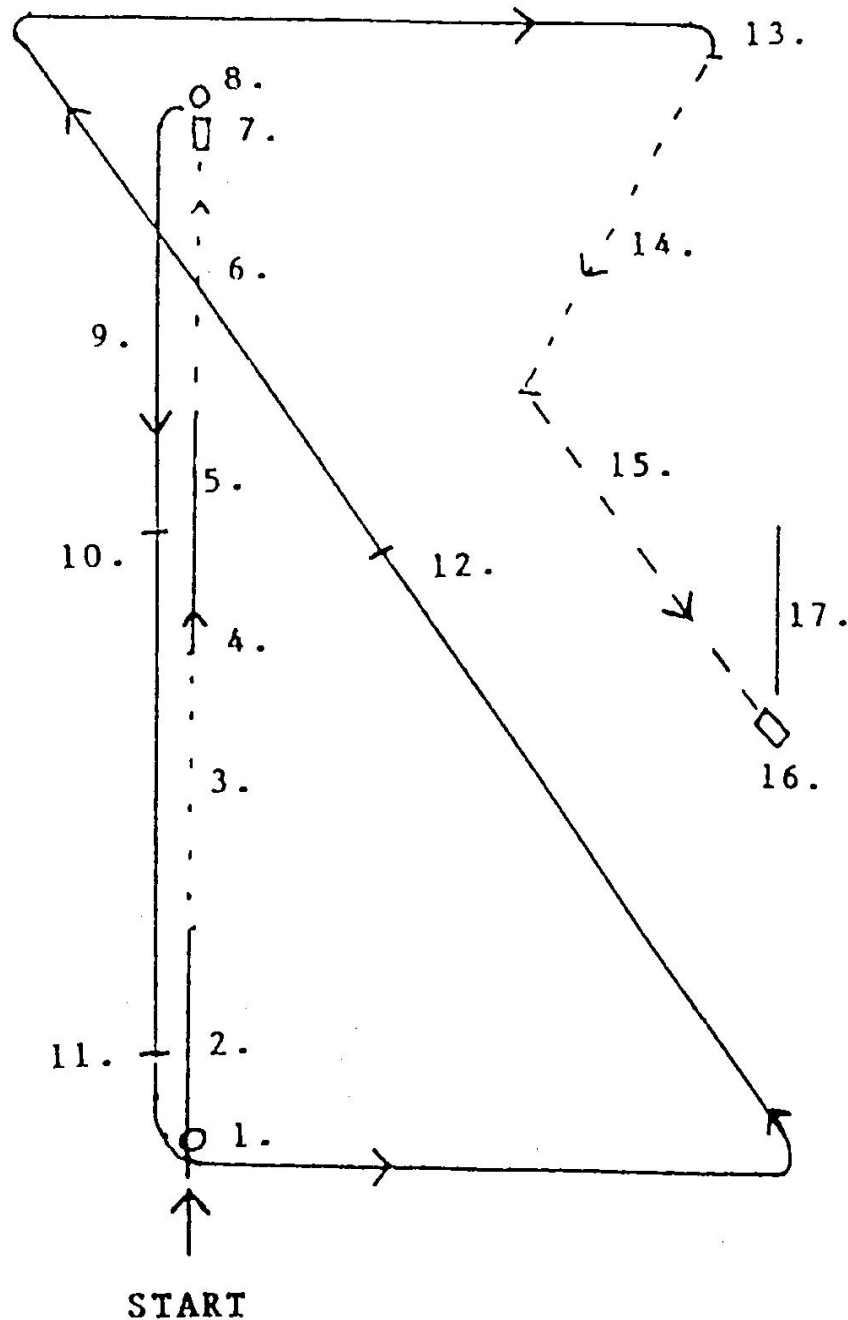

Class

6 English Horsemanship VI

- Judged on ability to perform Pattern #11 May be asked to perform any tasks in Levels I, II, III, IV, or V.

PATTERN #11

1. Turn on haunch 360° right
2. Right lead
3. Extended trot, left diagonal
4. Sit trot
5. Left lead
6. Extended trot, right diagonal
7. Halt
8. Turn on haunch left 180°
9. Left lead
10. Collected change right lead
11. Change to left lead
12. Collected change right lead
13. Drop to sitting trot
14. Two track to right
15. Two track to left
16. Halt
17. Back the horse 8 feet

5. 1 9 x 9 snack cake
6. 1 8 x 8 funny cake
7. 3 snickerdoodles
8. Poster or educational display on nutrition facts label
9. Any other project related item

DIVISION 17K- Cooking 301

1. 1 loaf yeast bread
2. 3 yeast rolls
3. 1 tea ring
4. 2 soft pretzels
5. 1 cup homemade granola
6. 1 cheese ball
7. 1 layer, unfrosted cake
8. Poster or educational display on grill safety
9. Poster, educational display or a notebook on a party you have planned
10. Any other project related item

Division 17L -Teens Entertain

Class

- 1 Educational exhibit with the recipes & nutritional information on at least one snack for each of the four seasons
- 2 The decorations
- 3 A collection of 25 recipes
- 4 Educational display of a proper table setting (poster, props, etc...)
- 5 Display depicting a teen-age birthday party. Include menu, theme, decorations and activities
- 6 Special-occasion dessert (include recipe) (4 servings)
- 7 Use of a low-calorie food (include recipe)
- 8 Nutritional snack - attractive (with one item made from scratch)
- 9 Centerpiece
- 10 Guide for a party (menu, time, guest list, and time schedule)
- 11 Any other project-related item

Division 17M -Let's Bake Bread

- This unit is designed for members who have completed several years of food-project work. One will learn the nutritional value, the function of each and interaction of ingredients.

- One will acquire the skills in selecting, preparing, serving and storing grain products. **Use standard-loaf-size pans or small bread pans.**

Class

- 1 3/4 loaf white-yeast bread on large meat tray
- 2 3/4 loaf 100% whole-wheat bread on large meat tray
- 3 3/4 loaf oatmeal bread on large meat tray
- 4 3/4 loaf rye bread on large meat tray
- 5 Plate of shaped-sweet-dough-rolls (cloverleaf, butter horns, fan tans, etc.) (4)
- 6 Variety rolls (4) (cinnamon, lemon, orange, pecan, etc.)
- 7 Variety bread or cake (orange-marmalade bread, loop coffee cake, basket weave coffee cake, hot-cross buns, stolen, etc) on a small meat tray (identify)
- 8 Bread-specialty item (bread basket, mushroom turtles, etc (identify)
- 9 Batter bread on a large meat tray (identify)
- 10 Baked product from refrigerator dough (include recipe)
- 11 3/4 loaf fancy bread
- 12 3/4 loaf holiday bread
- 13 3/4 loaf international bread
- 14 3/4 loaf sourdough bread
- 15 Exhibit of three breads made from three different types of flour
- 16 3/4 loaf bread prepared in microwave
- 17 One pocket bread
- 18 One bagel
- 19 Six crackers
- 20 One plate of pasta (noodles, spaghetti, etc) (1 dozen)
- 21 Sweet rolls (4)
- 22 Dinner rolls (4)
- 23 Cloverleaf rolls (4)
- 24 Crescent rolls (4)
- 25 Bowknot rolls (4)
- 26 3/4 loaf or 4 rolls made with cool-rise method
- 27 3/4 loaf bread or 4 rolls made with rapid mix method
- 28 3/4 loaf bread or 4 rolls made from your own recipe (include recipe)
- 29 Project manual
- 30 Any other project-related item

PATTERN #10
English Horsemanship V

1 2 .

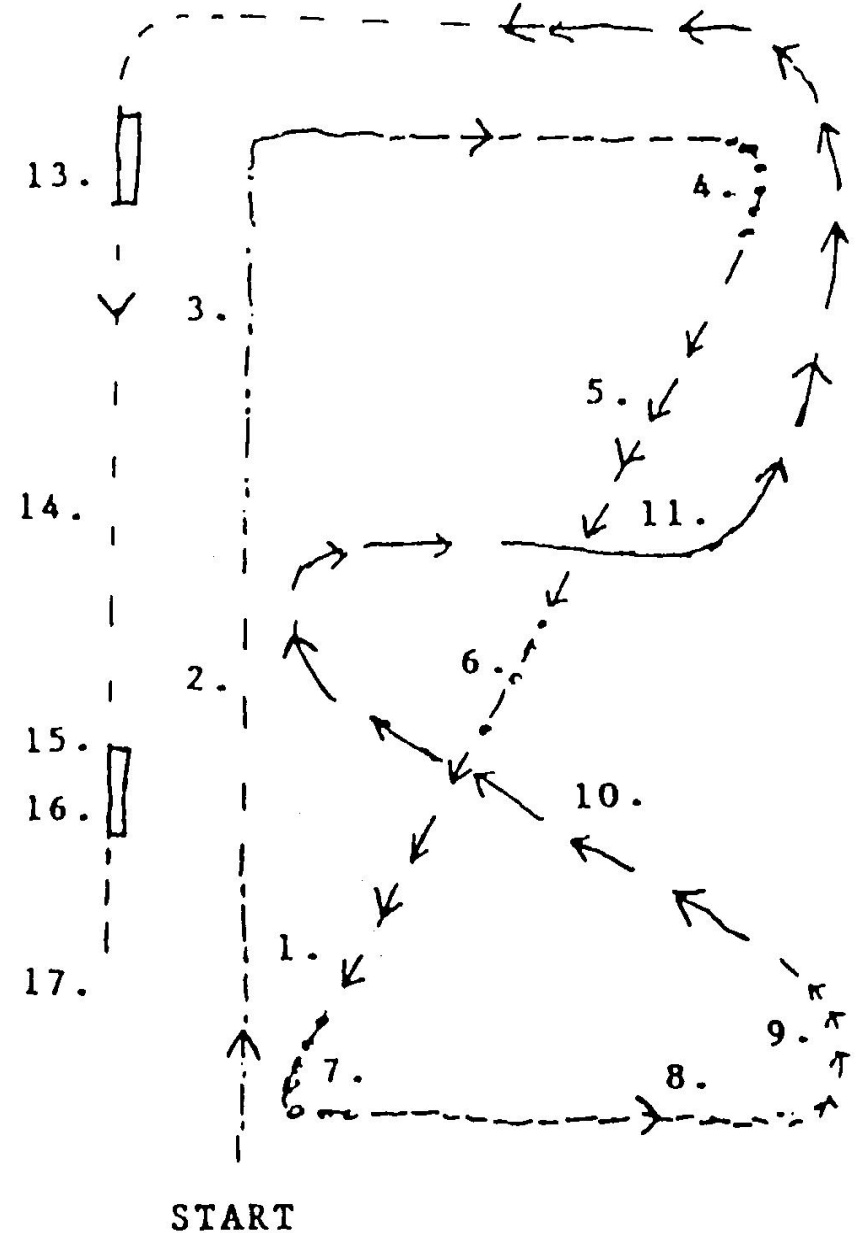

Class

5 English Horsemanship V

- Judged on ability to perform Pattern #10. May be asked to perform any tasks in Levels I, II, III, or IV

PATTERN #10

1. Walk
2. Collected sitting trot
3. Extended trot posting
4. Sitting trot
5. Canter right lead
6. Simple change left lead
7. Posting trot
8. Sit trot
9. Canter left lead
10. Simple change right lead
11. Simple change left lead
12. Sitting trot
13. Halt, turn on forehand 180° left, 180° right
14. Sitting trot
15. Halt, turn on haunch 180° right, 180° left
16. Settle 10 seconds
17. Retire to judge

Division 17N -Odds and Ends

Open to all members enrolled in food. These entries cannot be used in any other food-project entry. Winners of these classes will be eligible to compete in the Champion of Champions at the Eastern Montana Fair.

Class

- 1 Centerpiece, label for occasion or meal
- 2 Whole wheat bread, whole loaf (no mix) (100% whole wheat flour)
- 3 Fancy bread (3/4 loaf)
- 4 Bran muffins (4)
- 5 3-item gift basket, preserved food
- 6 Popcorn balls (3)
- 7 Mints (6)
- 8 Caramels (6)
- 9 Peanut brittle (6)
- 10 Cherry pie (no mix)
- 11 Apple pie (no mix)
- 12 Pecan pie
- 13 Drop cookies (4)
- 14 Bar cookies (4)
- 15 Decorated cookies (4)
- 16 Filled cookies (4)
- 17 White-layer-frosted cake, whole (no mix)
- 18 Novelty cake or cake designed from cut pieces
- 19 Decorated cake, special occasion such as birthday, anniversary, holiday, etc., showing tube skill

DEPT II Division 18 - FOOD PRESERVATION (Points 4, 2, 1)

Exhibits must state on entry blank the exact varieties being entered. Foods canned before the previous year's fair are not eligible for entry. Canned goods will not be judged unless standard, clear glass jars are used. All canning exhibits must be labeled with date filled and name of product. On the label of fruits, vegetables and meat, state the method of processing. All non-acid vegetables and meat must be canned in a pressure cooker.

Jelly will not be judged unless standard 1 pint or ½ pint jars are used with two-pieced lids and sealed. Jams, butter, marmalade, preserves and conserves must be sealed. Jar rings may be loosened but not removed.

This class is open to 4-H members entered in any Foods and Nutrition Project. Note: Exhibitors are encouraged to refer to judging criteria included in Open Class entries.

Division 18A -Jelly

Class

- | | |
|--|---------------|
| 1 Apple | 8 Grape |
| 2 Apricot | 9 Peach |
| 3 Buffalo Berry | 10 Plum |
| 4 Cherry or Sand Cherry | 11 Raspberry |
| 5 Chokecherry | 12 Strawberry |
| 6 Crabapple | 13 Any other |
| 7 Currant | |
| 14 Gift pack of 3 jellies (cannot use jars from above) | |

Division 18B -Jams, Butters, Marmalades, & Preserve

Class

- | | |
|---|--------------------------------------|
| 1 Apple Butter | 12 Orange Marmalade |
| 2 Apple Jam | 13 Peach Jam |
| 3 Apricot Jam | 14 Plum Butter |
| 4 Chokecherry Jam | 15 Plum Jam |
| 5 Crabapple Jam | 16 Raspberry Jam |
| 6 Crabapple Butter | 17 Rhubarb Combination
(identify) |
| 7 Cranberry Butter | 18 Strawberry Butter |
| 8 Grape jam | 19 Strawberry Jam |
| 9 Miscellaneous Butter | 20 Strawberry Preserves |
| 10 Miscellaneous Jam | 21 Any other |
| 11 Orange Jam | |
| 22 Gift pack of 3 jars (cannot use jars from above) | |

Division 18C -Pickles and Relishes

Class

- | | |
|---------------------------|-----------------------------|
| 1 Beet Pickles | 7 Lime Pickles |
| 2 Bread & Butter Pickles | 8 Miscellaneous Pickles |
| 3 Carrot Pickles | 9 Mustard Pickles |
| 4 Crabapple Pickles | 10 Sweet Pickles (cucumber) |
| 5 Cucumber Relish | 11 Watermelon Rind Pickles |
| 6 Dill Pickles (cucumber) | 12 Any other |

Division 18D -Canned Fruit

Class

- | | |
|--------------|---------------|
| 1 Apples | 6 Pears |
| 2 Applesauce | 7 Pie Filling |
| 3 Apricots | 8 Plums |
| 4 Cherries | 9 Any other |
| 5 Peaches | |

**PATTERN#9
English Horsemanship IV**

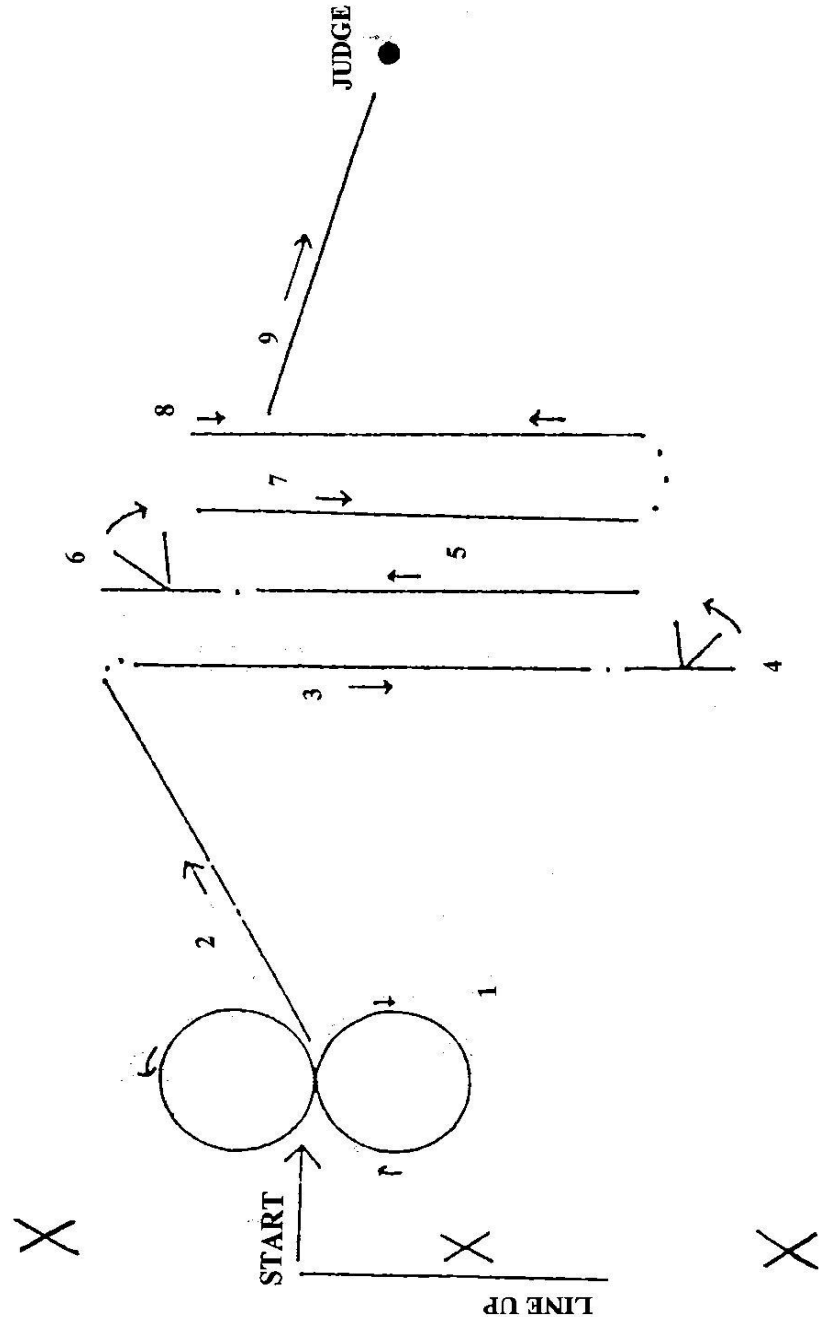

- Horse judged at walk, trot, extended trot, and canter using proper leads and diagonals. Riders may be asked to perform any task in English 1, name external anatomy, demonstrate leads, an/or diagonals

Class

3 English Horsemanship III

- May be asked to perform any task in English I or II
- Horse will be judged at a walk, trot and canter both ways of the ring using the correct lead. Posting trot and/or canter in a straight line around a pylon without breaking gait and return in a straight line. Back horse 10 steps while mounted.

Class

4 English Horsemanship IV

- Judged on ability to perform pattern #9 May be asked to perform any task in English I, II, or III.

PATTERN #9

1. Make two figure eights at the canter, with a simple lead change (drop to trot) - start with right lead.
2. Go to one end of arena. Walk a straight line.
3. From standing start, post a trot to other end of arena and halt.
4. Make a forehand turn toward judge.
5. Canter to the other end of the arena and halt
6. Turn on haunch toward the judge.
7. Canter to center of arena.
8. Make a smooth halt in the center of the arena and then back the horse 15 feet in a straight line.
9. Move forward to the judge for final instructions.

Division 18E -Vegetables

Tomatoes are listed in this class due to the canning process of them.

Class

- | | |
|-------------------|------------------|
| 1 Beans Green | 8 Pumpkin, cubed |
| 2 Beans Yellow | 9 Squash, cubed |
| 3 Beets | 10 Sauerkraut |
| 4 Carrots | 11 Tomatoes |
| 5 Corn | 12 Tomato Juice |
| 6 Mixed Vegetable | 13 Any other |
| 7 Peas | |

Division 18 F -Meat

Class

- | | |
|------------|-------------|
| 1 Antelope | 4 Deer |
| 2 Beef | 5 Pork |
| 3 Chicken | 6 Any other |

DEPT JJ Division 19 - FORESTRY

Division 19A –Follow the Path, Level 1 (Points 4, 2, 1)

1. Poster on a project related topic
2. Notebook which could include project related activities
3. Education display on a project related topic
4. Project Manual
5. Any other project related exhibit
6. Any other project related exhibit

Division 19B – Reach for the Canopy, Level 2

1. Poster on a project related topic
2. Notebook which could include project related activities
3. Education display on a project related topic
4. Project Manual
5. Any other project related exhibit
6. Any other project related exhibit

Division 19C – Explore the Deep Woods, Level 3

1. Poster on a project related topic
2. Notebook which could include project related activities
3. Education display on a project related topic
4. Project Manual
5. Any other project related exhibit
6. Any other project related exhibit

DEPT AA Division 20 – GOAT (Points 4, 2, 1)
Division 20A -Getting Your Goat, Dairy Goat Level 1

Class

- 1 A collection of pictures and information on different goat breeds
- 2 A poster with your drawing of a goat with the body parts labeled
- 3 A fictional story with goats as the main or secondary character
- 4 A collection of feed ingredients and an explanation of their uses
- 5 A poster with a picture of your goat pen and explain how you have made your goat area safe
- 6 A poster of all the goat products you can find in a store you visit
- 7 Poster of a goat teeth guide to determine the age of the goat
- 8 Project manual
- 9 Any other project-related item

Division 20B -Stepping Out, Dairy Goat Level 2

Class

- 1 A poster of a goat herd health problems including diseases, causes, symptoms and methods of prevention or treatment
- 2 Educational display of a goat medicine cabinet (Pictures or models can be substituted for needles and any other items)
- 3 Poster of the steps in the birth process and care of a newborn kid
- 4 Educational display of kidding supplies
- 5 A restraining box you have built
- 6 Poster or educational display of products that relate to goats and their unique features
- 7 A complete growth chart of your kid for 12 weeks
- 8 Project manual
- 9 Any other project-related item

Division 20C -Showing the Way, Dairy Goat Level 3

Class

- 1 A complete description with pictures of a goat field day you have planned and organized (Can be with a friend)
- 2 A complete description with pictures of a tot's barnyard you have planned and set up
- 3 A complete herd production and type chart of your goats
- 4 A health calendar of your herd
- 5 Labeled drawing with measurements showing proper Dairy Goat housing requirements
- 6 A nutrient ration you have formulated for your goat(s) (Poster or cards)
- 7 Project manual
- 8 Any other project-related item

Canter:

- Good - smooth, unhurried, consistent, steady
- Minor faults - too slow, too fast
- Major faults - strong lead, pulling, trotting behind, hard or rough riding
- Disqualification - not under control

Extended Trot/Canter:

- Good - strong, ground covering, smooth, consistent
- Minor faults - inconsistent speed
- Major faults - breaking gaits, pulling, hard / rough riding, uncontrolled
- Disqualification - no increase in speed

Back:

- Good - proper flexion, readily responsive, back in straight line
- Minor faults - hesitant, not backing straight
- Major faults - throwing head, gaping, pulling
- Disqualification - not backing, rearing

General:

- Good - smooth, steady, proper flexion and balance, good attitude
- Minor faults - over and under flexion, sour ears, switching tail, inconsistent speed, out of balance, poll too high or too low to throw horse out of balance, improper or incomplete appointments
- Major faults - throwing head, bad mouth, constant bumping the bit, gaping, evidence of altered tail carriage, obvious schooling
- Disqualification - constant breaking gaits, kicking, illegal equipment, lameness, cuing horse in front of cinch, fall of horse or rider

Division 6K -Horsemanship: English (Points 7, 4, 2)

See Horsemanship Manual Circular 1160 for division requirements.

Class

1 English Horsemanship I

- The horse will be judged at walk, trot and canter; post when trot. Riders may be asked to back, dismount and mount, unsaddle and saddle, name parts of bridle and saddle, execute correct diagonals.

Class

2 English Horsemanship II

- Horses may be neck reined or direct reined. Either method is acceptable; no additional credit will be given for neck reining.
- Horses will be judged at the walk, jog, lope on the rail both directions and lengthen and reduce each gait as directed by the judge. Rider may post the extended trot, but must sit the jog trot.
- Horses will be judged on ability to perform Pattern #7.

Class

4 Level IV

- Horse will show in a curb bit. Skid boots are optional for sliding stop.
- Horse must be neck reined.
- Horse will be judged on ability to quietly and accurately perform Pattern #8

General Requirements for English Horsemanship Classes

- The horse may be entered in English Horsemanship, but in only one division of English. (If a horse is also entered in Western Horsemanship, it can only be a maximum of two (2) levels different - higher or lower.)
- Dress Code: See General Rules. Entries must be shown hunt seat. Spurs and crop are optional.
- Snaffle bit - Smooth snaffle bit with broken mouthpiece (conventional 0-ring, egg butt, or D-ring) with ring no larger than 4" and no smaller than 2". From the cheek to one inch in from the cheek must be a minimum 3/8" diameter with a gradual decrease to the center of the snaffle. Optional loose curb strap (leather or nylon only and must be attached below the reins).

English Judging Criteria

Walk:

- Good - brisk, flat footed, good attitude
- Minor faults - slow, disinterested, not attentive
- Major faults - nervous, jiggling
- Disqualifications - not walking

Trot:

- Good - balanced, free moving, consistent, steady
- Minor faults - too slow, too fast
- Major faults - not performing a two-beat trot, failing to trot both front and back, hard or rough riding
- Disqualification - constant breaking

Division 20D – Just Browsing, Meat Goat Level 1

1. Poster on a project related topic
2. Notebook which could include project related activities
3. Education display on a project related topic
4. Project Manual
5. Any other project related exhibit
6. Any other project related exhibit

Division 20E – Growing with Meat Goats, Level 2

1. Poster on a project related topic
2. Notebook which could include project related activities
3. Education display on a project related topic
4. Project Manual
5. Any other project related exhibit
6. Any other project related exhibit

Division 20F – Meating the Future, Meat Goat Level 3

1. Poster on a project related topic
2. Notebook which could include project related activities
3. Education display on a project related topic
4. Project Manual
5. Any other project related exhibit
6. Any other project related exhibit

DEPT FF Division 21 - HOME ENVIRONMENT

The judge will determine the most outstanding Home Environment Exhibit which will be eligible to advance to the Champion of Champions contest at The Eastern Montana Fair.

Each category is open to any member enrolled in Home Environment.

Division 21A -Manual

Class

- 1 Design a room for someone in a wheelchair
- 2 Design a piece of furniture
- 3 Make a wooden puzzle
- 4 Throw a clay pot
- 5 Make a porch or patio
- 6 Design a sound system
- 7 Make a picture or wall hanging
- 8 Make paper
- 9 Make a stitchery project
- 10 Make a calendar

- 11 Select, spin, wash and hang wool to display
- 12 Renovate anything old
- 13 Make a photo display of old houses
- 14 Trace the history of an item in your home
- 15 Paint the outside of your home
- 16 Construct a quilt for a bed
- 17 Compare prices of wallpapers
- 18 Compare qualities and costs of windows and glass
- 19 Select ceramic tile and clay counter top or wall
- 20 Select cookware, microwave or flatware
- 21 Project manual
- 22 Any other project-related item
 - 23 Project completed in The Basic Touch, designing walls, windows and floors
 - 24 Project completed in The Distinctive Touch, furniture, fabrics and storage
 - 25 Project completed in The Finishing Touch, accessorizing our room
 - 26 Project completed in The Environmental Touch

DEPT AA Division 22 - HORSE (Points 4, 2, 1)

Division 22A - Horse I – Giddy Up and Go

All of the classes in division 20 may be entered by members enrolled in any horse project

Class

- 1 A picture of a horse you drew from memory, a picture of a horse you drew from a picture and a list of the differences between the two pictures
- 2 A horse breed collage of at least ten different breeds and identify each breed
- 3 A set of at least 25 horse breed flash cards
- 4 A collection of pictures or drawings of at least 20 different horses (Label each picture with what you believe each horse is communicating)
- 5 A story you have written using at least 15 words from Horse Talk 1 glossary
- 6 A poster of your drawing of a horse with at least 20 body parts labeled
- 7 A horse puzzle you have made

Division 6J -Green Horse (Points 7, 4, 2)

This project is for members who have horses that are not fully trained, but do not fit into the colt-to-maturity project because of age or ability. Open only to mares and geldings.

Class

1 Level I

- Animal will show best with a ring snaffle bit or a rawhide hackamore (bosal). The use of running martingale or German Olympic martingale is permissible, but not mandatory. Other martingales, tie downs and bits are not permitted (shank bits are not permitted).
- Horses will be direct reined only (rein held in each hand).
- Horses will be judged on ability to perform Pattern #.
- Other tasks the contestants may be asked to perform are:
 - Halt (not sliding stop)
 - Dismount and mount
 - Unsaddle and saddle up
 - Back while dismounted
 - Name parts of animal, equipment and nutrition

Class

2 Level II

- Animal will show best with a ring snaffle bit or a rawhide hackamore (bosal). The use of running martingale or German Olympic martingale is permissible, but not mandatory. Other martingales, tie downs and bits are not permitted (shank bits are not permitted).
- Horses may be neck reined or direct reined. Either method is acceptable; no additional credit will be given for neck reining. Spurs should not be used forward of the cinch.
- Horses will be judged on Pattern #6.
- Other tasks the contestant may be asked to perform are:
 - Requirements from class No.1
 - Identify leads

Class

3 Level III

- Animal will show best with a ring snaffle bit or a rawhide hackamore (bosal). The use of running martingale or German Olympic martingale is permissible, but not mandatory. Other martingales, tie downs and bits are not permitted (shank bits are not permitted)

PATTERN#8
Five-Year-Old Under Saddle (Western)

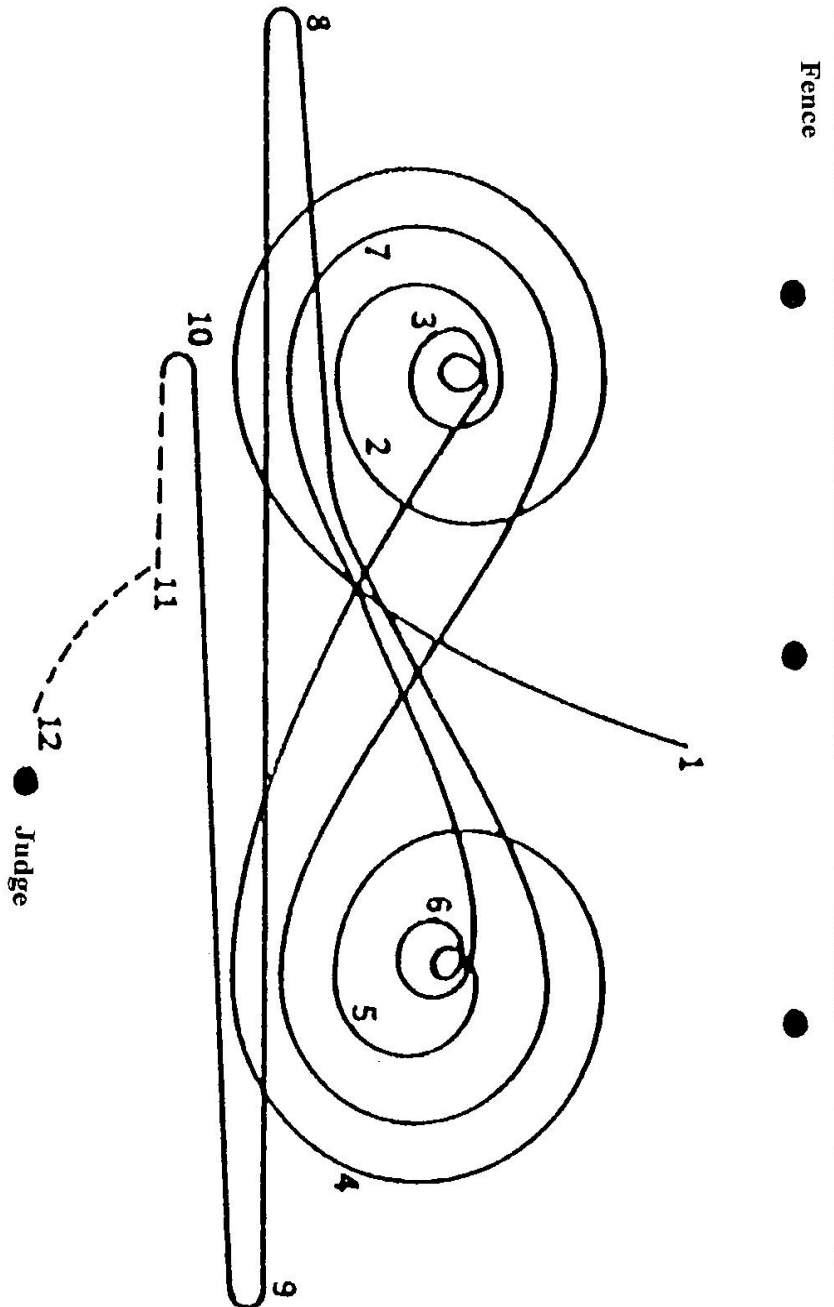

- 8 A poster where you have drawn and labeled the parts of a Western Saddle, English Saddle, Western Bridle and an English Bridle
- 9 A set of at least 20 flash cards of horse tack and equipment
- 10 A labeled collection of at least five different feed ingredients fed to horses
- 11 Something you have planned, designed, and built that you can really use with a horse
- 12 A poster on some aspect of horse safety
- 13 Project manual
- 14 Any other project-related item
- 15 Any horse related project you have made
- 16 Any other horse related project you have made

Division 22B - Horse II – Head, Heart and Hooves

Class

- 1 A chart of results where you have tested three horses' behavioral traits and disposition
- 2 A poster, educational display or notebook on different horse career options
- 3 A poster showing the results of a water absorbing experiment and decay experiment on at least four different bedding materials
- 4 A poster with a detailed drawing of your horse and a written description of your horse
- 5 Poster with your drawing of a horse with at least 20 different blemishes or unsoundness
- 6 A poster showing the differences in a horse's teeth at the age of two, seven, fifteen, and twenty
- 7 An emergency kit for both rider and horse
- 8 A parasite chart of at least 12 external and internal parasites (Include symptoms, prevention and treatment)
- 9 poster of drawing of a horse's hoof with at least 14 labeled parts
- 10 Results of your feed storage experiment using four grains and two different types of hay
- 11 Project manual
- 12 Any other project-related item
- 13 Any horse related project you have made
- 14 Any other horse related project you have made

Division 22C - Horse III – Stable Relationships

Class

- 1 promotional campaign for horses that you have planned and designed

- 2 Notebook with pictures explaining a horse judging contest you have planned and conducted
- 3 Your diary and pictures of a camping experience with horses
- 4 A twelve month horse health plan you have designed
- 5 Pictures and explanation of young horse training skillathon you have planned and conducted
- 6 Your results after conducting a horse economic impact survey
- 7 A newspaper advertisement for a horse related business that you have created
- 8 Project manual
- 9 Any other project-related item
- 10 Any horse related project you have made
- 11 Any other horse related project you have made

**DEPT LL Division 23 – HORTICULTURE/GARDENING
(Points 4, 2, 1)**

Division 23A -Unit 1 - Budding Gardeners

Class

- 1 Poster or display identifying plant parts and their functions
- 2 Poster or display explaining about bulbs, rhizomes, corms and tubers
- 3 Poster that shows how seeds germinate
- 4 Educational display or poster showing results of too much or too little water and sunlight on plants
- 5 A compost column and list of what to put in a compost column, what not to put in and why
- 6 Poster or display explaining tropisms
- 7 Notebook on different plants that grow in your county (pictures, names, and any additional info)
- 8 Propagated plant and explanation of the propagation method
- 9 Poster identifying the parts of a flower
- 10 A simple line flower arrangement
- 11 A dish garden
- 12 A vegetable plant grown in a container with explanation included
- 13 An outdoor garden plan
- 14 Chart comparing nutritional value of raw, canned and frozen vegetables
- 15 Project manual
- 16 Any other exhibit using information learned in Unit 1

Class

- 5 Five-Year-Old under Saddle - Western
 - Open to five-year-old mares and geldings. Horse will show in a curb bit. Skid boots are optional for sliding stop.
 - For other equipment, refer to "General Requirements".
 - Horse must be neck reined.
 - The horse will be judged on his ability to quietly and accurately perform the designated pattern. For riding pattern and explanation, see Pattern #8. Follow the explanation for Western Riding Pattern.

PATTERN #8

For Western Ride Pattern:

1. Starting in the center of the arena make a large fast circle to the right.
2. Make three circles to a small circle until you reach the center of the arena. Stop
3. Do a double spin (720°) to the inside of the small circle in the center of the arena - at the end of the spins, the horse should be facing in direction from where started spin.
4. Begin on the left lead and make a large fast circle
5. Make three circles again drawing it down to the center of the arena - stop - no hesitation on these stops
6. Do a double spin (720°) to the inside of the circle - slight hesitation - horse to be facing direction from where spin started
7. Begin on right lead and make a fast figure eight over the large circle - close the eight - and change leads.
8. Run to far end of the arena and do a left roll back
9. Run to opposite end of arena and do a right roll back
10. Run back past center of the arena and do a sliding stop - Hesitate
11. Back over slide tracks
12. Finish - walk to judge for inspection and dismissal

- 11-12. Trot a circle to the right making it progressively smaller until horse is holding his hindquarters in one spot, crossing his front legs to walk around a complete 360°
- 12-13. Walk horse - 20 feet
13. Stop
- 13-14. Turn left on the haunch with horse crossing his front legs to walk 180°
- 14-15. Turn right on the haunch with horse crossing his front legs to walk 180°
- 15-16. Retire the arena

PATTERN #7

Four-Year-Old under Saddle (Western)

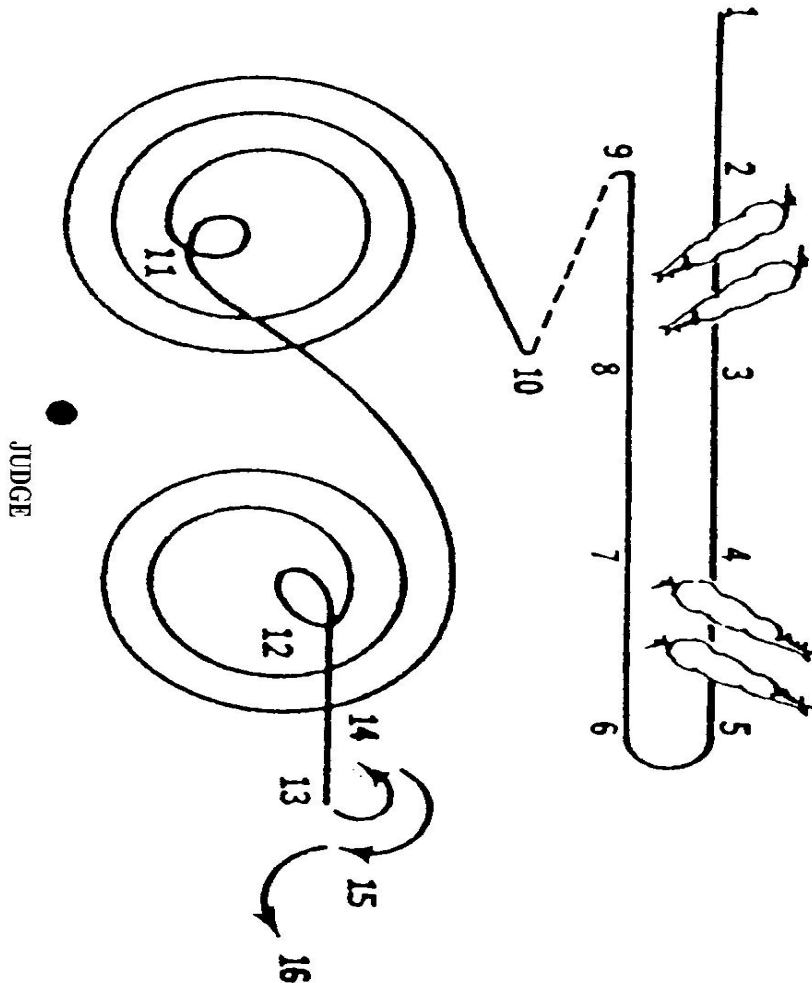

Division 23B -Unit 2 - Branching Out

Class

- 1 Results of an experiment you conducted on plants
- 2 Results of an experiment you conducted on seeds
- 3 Host plant and new plant in process of air layering propagation
- 4 plant grown without soil & an explanation of what you did & learned
- 5 A terrarium
- 6 Pictures and explanation of your own compost pile
- 7 A chart listing at least 20 plants for transplanting (Include starting time and growing time)
- 8 Results of a soil sample from your yard and what you need to add to the soil
- 9 Chart on kinds of mulch and the advantages and disadvantages of using each kind
- 10 A perennial flower garden plan showing heights, color and blooming for the different seasons
- 11 An annual flower garden plan showing heights and color
- 12 chart identifying plant pests a description of each& the damage they do
- 13 A complete income and expense statement of your garden project
- 14 A mass flower arrangement
- 15 Any other exhibit using information learned in Unit II.

Division 23C -Unit 3 - Digging Deeper

Class

- 1 Pictures and explanation of a cold frame you have built and used
- 2 A landscape plan, of your design, to improve a site in your community
- 3 A notebook covering all aspects of a Gardening Clinic you planned, implemented and evaluated
- 4 Results of at least two plant experiments you have designed and implemented
- 5 A notebook with plans and results for teaching others how to grow a herb garden
- 6 A line - moss flower arrangement
- 7 A poster with instructions and illustrations on how to force bulbs
- 8 A chart comparing organic to traditional gardening
- 9 A notebook with your complete design of a video on perennial division
- 10 A complete marketing plan to sell horticulture products in your county

- 11 An informative chart about different careers in horticulture
- 12 Project manual
- 13 Any other exhibit using information learned in Unit III.

Division 23D -Horticulture - Floral
Open to any youth enrolled in Horticulture

Class

- 1 Display a started plant or tree with an index card telling what you did, plant name, and problems you encountered
- 2 Poster using varying types of plant seeds & show how each is used
- 3 Exhibit a product that you have grown, on index card-label product and explain what you did in project and uses of product
- 4 Floral arrangement (use flowers you have grown), display flowers in an appropriate container
- 5 Aster, 3 stems
- 6 Bachelor Buttons, 6 stems
- 7 Bells of Ireland, 3 stems
- 8 Calendula, 6 stems
- 9 California Poppy, 3 stems
- 10 Calliopsis, 6 stems
- 11 Carnations, 3 stems
- 12 Cosmos, 3 sprays
- 13 Dahlias, 3 stems
- 14 Daisy, African, 6 stems
- 15 Daisy, English, 6 stems
- 16 Lilies, 1 stalk
- 17 Gaillardia, 4 stems
- 18 Golden Glow, 3 sprays
- 19 Larkspur, 6 stems
- 20 Marigold, 3 stems
- 21 Marigold, dwarf, 6 stems
- 22 Pansy, 3 stems
- 23 Petunia, single, 3 stems
- 24 Gladiolus, 1 spike
- 25 Petunia, double, 3 stems
- 26 Phlox, 3 stems
- 27 Phlox, perennial, 1 stems
- 28 Pinks, 6 stems
- 29 Poppy, annual, 3 stems
- 30 Rose, 3 stems
- 31 Straw Flowers, 4 stems

Class

- 4 Four-Year-Old Under Saddle - Western
 - Open to four-year-old mares and geldings. Animal will show best with a ring snaffle bit or rawhide nose band hackamore (bosal) using two hands; however, if a contestant desires a curb bit, one hand can be used. The use of a German Olympic martingale or running martingale may be used when using a ring snaffle only, but it is not mandatory. However, other martingales and tie downs are not permitted.
 - For other equipment, refer to "General Requirements".
 - Horses may be neck reined or direct reined. Both methods are acceptable, and no additional credit will be given for neck reining.
 - Horses will be judged at the walk, jog, lope on the rail both directions and lengthen and reduce each gait as directed by the judge. Rider may post the extended trot, but must sit the jog trot. Each individual will also be judged on Pattern #7.
 - Other tasks the contestant may be asked to perform are:
 - Requirements from classes 1 and 1
 - Parts of the animal, equipment and nutrition

PATTERN #7

Retire to one end of the arena where each rider will perform the following pattern individually:

- 1-2 Trot straight ahead, sitting the trot, 25 feet
- 2-3. Side pass to the left - 15 feet - at the walk
- 3-4. Trot straight ahead, sitting the trot
- 4-5. Side pass to the right - 15 feet - at the walk
5. Strike off the right lead
- 5-6. Lope in right lead - 30 feet
6. Stop, settle horse
- 6-7. Strike off left lead 30 feet
7. Stop, settle horse
- 7-8. Strike off right lead - 30 feet
8. Stop, settle horse
- 8-9. Strike off left lead - 3
- 9-10. Backing horse - 10 to 12 feet
- 10-11. Trot to the left making circle progressively smaller and smaller until horse is holding hindquarters in one spot and crossing his front legs to walk around a complete 360°

- 13-14 Trot to the left making the circle progressively smaller drawing down to three circles until the horse is holding hindquarters in one spot and crossing his front legs to walk around 180° turn
- 14-15 Trot to right making the circle progressively smaller drawing down to three circles until horse is holding hindquarters in one spot and crossing his front legs to walk around 180° turn
- 15-16 Trot
- 16 Stop
- 16-17 Back 10 feet
- 17 Stop, settle horse for 10 seconds
- 18 Retire to judge for inspection

PATTERN#6

Three-year-old Under Saddle (western)

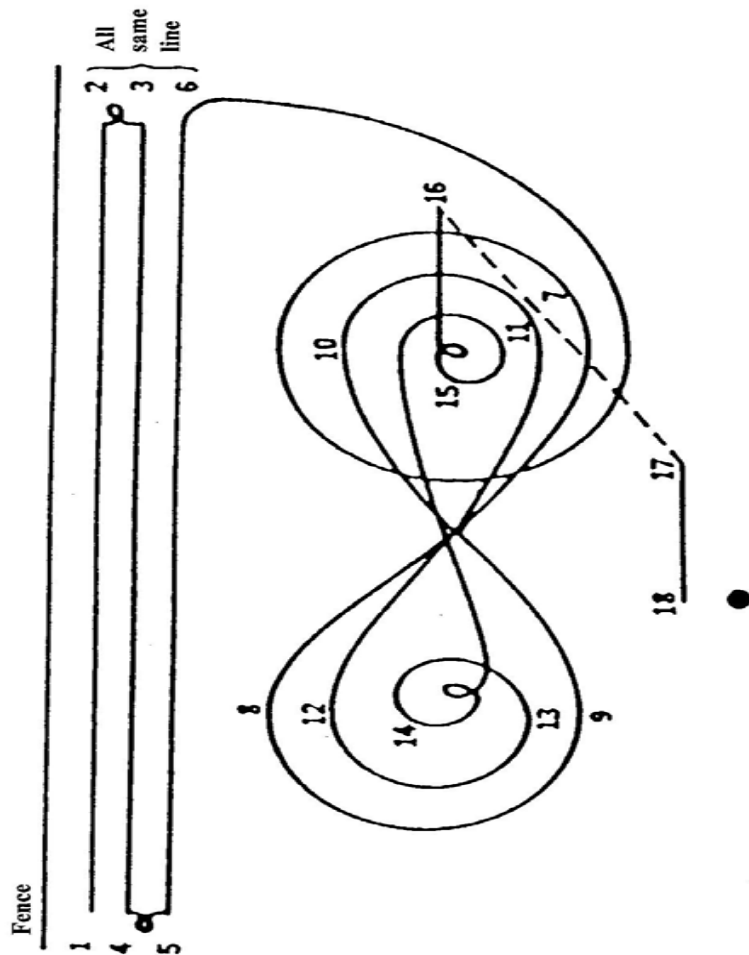

- 32 Sweet Sultan, 6 stems
- 33 Sweet Pea, 6 stems
- 34 Stocks, 3 stems
- 35 Snapdragons, 3 stems
- 36 Nasturtiums, 3 stems
- 37 Nicotiana, 6 stems
- 38 Zinnia, Pompom, 1 stems
- 39 Zinnia, Giant, 1 stems
- 40 Container vegetable
- 41 Container flowering plant
- 42 Container herb
- 43 Container plant, grown from slip or cutting, bulb or root
- 44 Bedding plant
- 45 Begonia
- 46 Foliage plant
- 47 Geranium
- 48 African Violet
- 49 Hanging plant
- 50 Notebook on landscape plan, include pictures
- 51 Educational display on landscape
- 52 Pint of cherries
- 53 Pint of strawberries
- 54 Pint of gooseberries
- 55 Pint of currants
- 56 Pint of raspberries
- 57 Pint of choke cherries
- 58 Any other fruit, 1 pint

**Division 23E -Horticulture - Vegetables
Open to any youth enrolled in Horticulture**

Exhibits that do not contain the required number of vegetables will not be considered for awards. Exhibits will be judged for uniformity, maturity, varietal characteristics, freedom from injury and disease.

Class

- 1 Asparagus, 6 spears
- 2 Beans, pole, 10 pods
- 3 Beans, yellow, 10 pods
- 4 Beans, green, 10 pods
- 5 Beans, purple, 10 pods
- 6 Beets, 3

- 7 Broccoli, 1 head
- 8 Brussel sprouts, 6
- 9 Cabbage, round, 1
- 10 Cabbage, conical, 1
- 11 Cabbage, flat, 1
- 12 Cabbage, red, 1
- 13 Cantaloupe or muskmelon, 1
- 14 Carrots, oxheart, 4
- 15 Carrots, half long, 4
- 16 Carrots, long, 4
- 17 Cauliflower, 1
- 18 Celery, 1 bunch
- 19 Citron, 2
- 20 Cucumber, burpless, 3
- 21 Cucumber, slicing, 3
- 22 Cucumbers, pickling, 6
- 23 Dill, 3 heads
- 24 Eggplant, 1
- 25 Endive, 2
- 26 Kohlrabi, 3
- 27 Lettuce, best pale heads, 1
- 28 Okra, 4
- 29 Onions, brown or yellow, 3
- 30 Onions, white, 3
- 31 Onions, pickling, 6
- 32 Onions, green bunching, 6
- 33 Parsley, 1 plant
- 34 Parsnips, 3
- 35 Peas, 10 pods
- 36 Peppers, red, 3
- 37 Peppers, green, 3
- 38 Unlisted peppers, (Identify)
- 39 Pumpkin, 1
- 40 Pumpkin, small sugar, 2
- 41 Largest pumpkin, 1, judged by weight
- 42 Radishes, 6
- 43 Rutabagas, 3
- 44 Rhubarb, 6 stalks
- 45 Squash, table queen, 1
- 46 Squash, buttercup, 1
- 47 Squash, Hubbard, 1

Class

- 3 Three-Year-Old Under Saddle - Western
 - Open only to three-year-old mares and geldings. Animal will show best with a ring snaffle bit, or a rawhide noseband hackamore (bosal). The use of a German Olympic martingale or running martingale is recommended but not mandatory. Other martingales, tie downs and bits are not permitted. (Shank bits are not permitted).
 - For other equipment, refer to "General Requirements".
 - Horses may be neck reined or direct reined. Either method is acceptable; no additional credit will be given for neck reining. Spurs should not be used forward of the cinch.
 - Horses will be judged at the walk, jog, lope on the rail both directions and lengthen and reduce each gait as directed by the judge. Each individual will also be judged on Pattern #6.
 - Other tasks the contestant may be asked to perform are:
 - Requirements from class I and class 2
 - Identify leads
 - Parts of animal, equipment and nutrition

PATTERN #6

Retire to one end of the arena where each rider will perform the following-pattern individually:

- 1-2 Trot along side of fence about 100 feet
Stop
- 2-3 Turn on forehand (front feet stay in two foot circle) with hindquarter moving to the right
- 3-4 Trot back toward starting point along the fence
Stop
- 4-5 Turn on the forehand (keep front feet in two foot circle) with hindquarter moving to the left
- 5-6 Trot along fence striking into a lope as the rider begins the Figure 8 and go around Circle A once at the lope
- 7 Drop to a trot
- 8 Pick up new lead and go around Circle B at the lope
- 9 Drop to a trot
- 10 Pick up new lead and go around Circle A
- 11 Drop to a trot
- 12 Pick up new lead and go around Circle B

PATTERN #5
Two year old under saddle

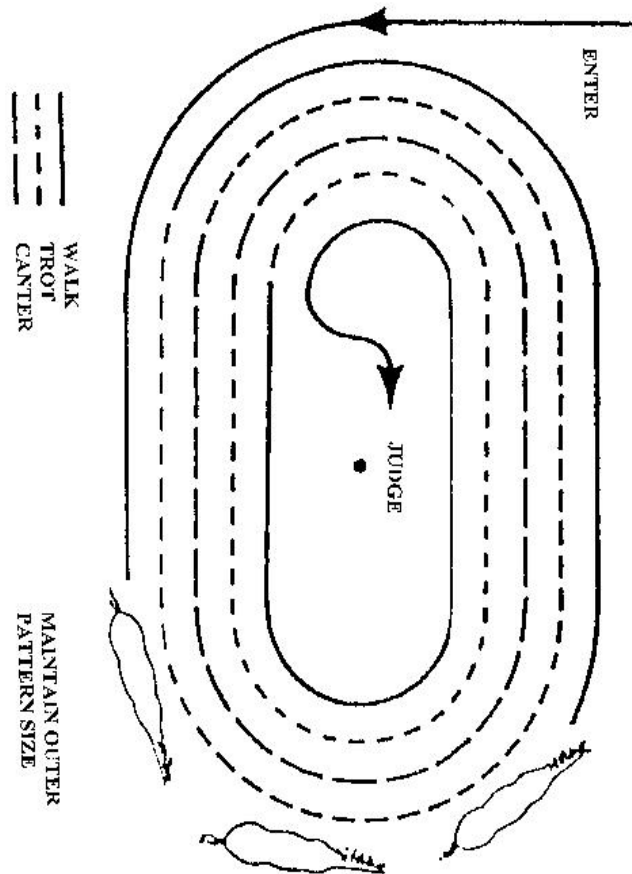

- 48 Squash, marble, 1
- 49 Squash, any other winter, 1, and identify
- 50 Squash, Zucchini, 2, 8 in. or under
- 51 Squash, Zucchini, 1, largest, judged by weight
- 52 Squash, yellow, straight and crookneck, 2
- 53 Squash, white or scallop, 2
- 54 Squash, other summer, 2 (Identify)
- 55 Squash, largest, 1, judged by weight
- 56 Swiss chard plant, 3
- 57 Sweet corn, 3
- 58 Turnips, table, 3
- 59 Tomatoes, red, 3
- 60 Tomatoes, green, 3
- 61 Tomatoes, small ripe, 5
- 62 Tomatoes, yellow pear, 5
- 63 Watermelon, 1
- 64 Largest watermelon, 1, by weight
- 65 Any other vegetable, if similar vegetable to carrot, beet or corn, bring 4, If pea or bean-type vegetable, 10
- 66 Potatoes, round red, 6
- 67 Potatoes, early round white, 6
- 68 Potatoes, russet, 6
- 69 Potatoes, any other not previously listed (Identify) (Blue Victor, Purple Flesh, etc.), 6
- 70 Sprouts, display in a clear container
- 71 Gourds, 2
- 72 Unique-shaped vegetable

DEPT FF Division 24 - LEADERSHIP (POINTS 4, 2, 1)

Class

- 1 A notebook including your plan and reports of accomplishments with supporting materials for any of the activities carried out
- 2 A poster or display highlighting an area of your leadership
- 3 Any other project-related item

DEPT JJ Division 25 - LEATHER CRAFT (Points 5, 3, 2)

Each exhibit winning best of division is eligible to advance to the Champion of Champions contest at the Eastern Montana Fair.

Division 25A -Unit 1

Class

- 1 Bookmark
- 2 Comb case
- 3 Bag tag
- 4 Coin purse
- 5 Key case
- 6 Knife sheath
- 7 Pencil holder
- 8 Wristband
- 9 Billfold
- 10 A minimum of 3 coasters depicting your stages of progress in unit
- 11 Beading on leather
- 12 Any other item using whip stitch
- 13 Any other item using running stitch lacing
- 14 Any other item using a pear shader
- 15 Any other item showing beveling with a modeling tool
- 16 Any other item showing use of the veiner tool
- 17 Any other item showing use of a seeder tool
- 18 Any other item showing use of a back grounder tool
- 19 Any other project-related item

Division 25B -Unit 2

Class

- 1 Checkbook cover
- 2 Small purse
- 3 Belt buckle
- 4 Pocket saver
- 5 Key case
- 6 ID and picture case
- 7 Eyeglass case
- 8 Knife sheath
- 9 Swivel knife sheath
- 10 A minimum of 3 coasters depicting your stages of progress in unit
- 11 Any other item showing use of swivel knife
- 12 Any other item showing use of camouflage tool
- 13 Any other item showing use of beveling tool
- 14 Any other item using double loop lacing

Class

2 Two-Year-Old Under Saddle - Western

- Open only to two-year-old fillies and geldings. Animal will show best with a ring snaffle bit, or a rawhide hackamore (bosal). The use of running martingale or German Olympic martingale is permissible, but not mandatory. Other martingales, tie downs and bits are not permitted (shank bits are not permitted).
- For other equipment, refer to "General Requirements".
- Horses will be direct reined only (rein held in each hand).
- Horses will be judged at the walk, trot and lope both directions of the ring.
- Perform pattern # 5.
- Other tasks the contestant may be asked to perform are:
 - Halt (not sliding stop) from the walk
 - Dismount and mount
 - Unsaddle and saddle up
 - Back while dismounted
 - Parts of the animal, equipment and nutrition

**PATTERN #5
Two-Year-Old under Saddle**

Enter ring counter clockwise at a walk at judge's direction; increase to a trot, maintain until judge asks to increase to a lope (canter), hold until judge asks you to trot then to walk. Switch directions turning toward judge and repeat. Halt from a walk at judges direction.

Division 6G -Level VII (Points 7, 4, 2)

Class

1. Required mounted abilities
 - Rider to execute the pattern using skills from required mounted abilities from level VI
 - Pattern to be developed by rider and submitted with registration and entry
 - It will be provided to judge before the class begins
 - Patterns may be choreographed to music
 - Single exhibitor and horse to perform pattern
 - Setup time, performance of pattern, and tear down time not to exceed 4 minutes. Time limit will be enforced

Dept P Division 6H -Horse Breeding (Points 5, 3, 2)

- The dam and offspring need to be biologically related.
- The dam and offspring need to be present for judging only. They may be returned home, not kept on the fairgrounds unless prior arrangements have made and approved of.
- The offspring would have been born on or after January 1, of current year.

Class

1. Dam and Offspring (The objective of this class is to show member has improved on the conformation of offspring.)
2. Project book and/or notebook recording all details of project.

Division 6I -Training a Colt to Maturity (Points 7, 4, 2)

Refer to Bulletin 353 "Training Horses -Yearling to 5 Year Old" for additional requirements.

Class

1. Yearling
 - Each club member will show his or her colt while standing at the walk, at the trot, backing and be able to pick up all four feet. Refer to Montana 4-H Showmanship Guide, Circular 1287. May be shown in Western or English attire and tack.

- 15 Any other item showing decorative cuts
- 16 Any other project-related item

Division 25C -Unit 3

Class

- 1 Barbecue seat
- 2 Belt
- 3 Belt and holster
- 4 Book cover
- 5 Notebook
- 6 Pistol caddy
- 7 Purse
- 8 Quiver and arm guard
- 9 Travel or toiletry bag
- 10 Wallet
- 11 A minimum of 3 coasters depicting your stages of progress in unit
- 12 Any other item showing inverted carving techniques
- 13 Any other item showing beginning dyeing
- 14 Any other item showing lining
- 15 Any other item showing simple molding or shaping
- 16 Any other item showing hand stitching
- 17 Any other project-related item

Division s 25D -Advanced Leather craft Units 4

Class

- 1 Advanced carving skills with or without beginning dyeing on item
- 2 Advanced carving skills colored by solid-color dyeing, block dyeing, or shade dyeing on item
- 3 One framed or mounted, carved-leather picture (Item may be stained or colored)
- 4 One completed saddle, tooled or un-tooled
- 5 One article or matching set using creative stamping
- 6 One article or matching set using non-tooled or minimal tooling and non-sewn-leather-working techniques
- 7 One article made by sewing leather
- 8 Any other project-related item

Dept FF Division 26 – NEEDLEWORK (Points 5, 3, 2)

Judge will determine most outstanding Crocheted item, Knitted Item, Embroidery item, and Cross Stitch item. These items will be eligible to advance to Champion of Champions at the Eastern Montana Fair.

Division 26A -Knitting

Class

- 1 Scarf
- 2 Hat
- 3 Two-needle mittens
- 4 Two-needle sport anklet
- 5 Slippers
- 6 Knitted pillow
- 7 Pair of potholders
- 8 Socks - 2 colors
- 9 Slippers - 2 colors
- 10 Mittens - 2 colors
- 11 Sweater with raglan sleeves
- 12 Novelties (stuffed toys)
- 13 Item using cable stitch
- 14 Item using moss or seed stitch
- 15 Item with buttonholes
- 16 Sweater set (pullover and cardigan)
- 17 Coat sweater with design
- 18 Article using circular needles (skirt, sweater, etc.)
- 19 Socks or cap using four needles
- 20 Afghan
- 21 Any other project-related item

Division 26B -Crochet

Class

- 1 Bookmark
- 2 Basket
- 3 Christmas item
- 4 Poster showing examples of stitches: SC, DC, TC
- 5 Potholders, set of 2
- 6 Napkin rings, set of 2
- 7 Collection of 3 bazaar items
- 8 Sweater
- 9 12" dolly or centerpiece
- 10 Baby afghan
- 11 Afghan

**PATTERN#4
Horsemanship VI (Western)**

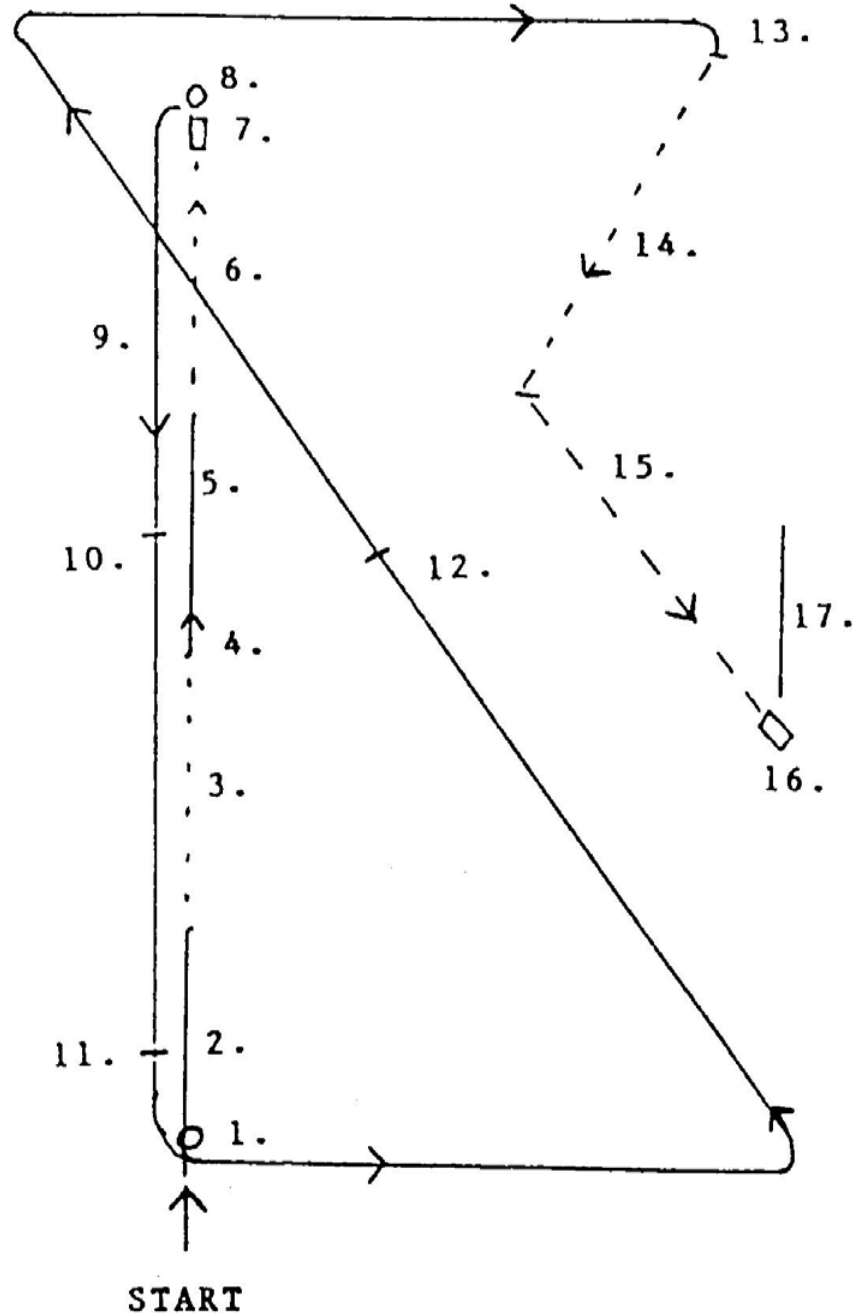

Division 6F -Level VI

Class

1. Perform any tasks in Levels I, II, III, IV and V.

The horse will be judged on his ability to perform Pattern #4.

PATTERN #4

1. Hindquarter turn 360° right.
2. Right lead.
3. Trot.
4. Trot.
5. Left lead.
6. Trot.
7. Stop.
8. Hindquarter turn 180° left.
9. Left lead.
10. Change right lead.
11. Change left lead.
12. Change right lead
13. Trot
14. Two track to right.
15. Two track to left.
16. Stop.
17. Back the horse 8 feet.

12 Rug

13 Notebook on examples of crocheting with different mediums

14 Any other project-related item

Division 26C -Embroidery

All wall hangings must be mounted properly and backed.

Class

- 1 Potholder (2)
- 2 Pincushion
- 3 Pillow top
- 4 Simple design on scarf, towel, clothing item or any other article
- 5 Small picture with frame
- 6 Simple pillow cases (2) (in plastic bag)
- 7 Article using cross stitch
- 8 One article using four or more different embroidery stitches
- 9 Embroidered luncheon cloth (over 34" up to 54" in size)
- 10 Cross-stitched luncheon cloth (over 34" up to 54" in size)
- 11 Embroidered table cloth (over 54")
- 12 Cross-stitched table cloth (over 54")
- 13 Embroidered doilies (under 12")
- 14 Cross-stitched doilies (under 12")
- 15 Embroidered centerpiece (12" to 34" in size)
- 16 Cross-stitched centerpiece (12" to 34" in size)
- 17 Embroidered dresser scarf
- 18 Cross-stitched dresser scarf
- 19 Embroidered towels (set of 2)
- 20 Cross-stitched towels (set of 2)
- 21 Embroidered pillow cases (set of 2)
- 22 Cross-stitched pillow cases (set of 2)
- 23 Embroidered sofa pillow
- 24 Cross-stitched sofa pillow
- 25 Article using chicken - scratch stitch
- 26 Article using candle wicking
- 27 Place mats (set of 2)
- 28 Set of pictures (2)
- 29 Wall hanging
- 30 Design on clothing item
- 31 Article with six or more stitches
- 32 Crewel wall hanging
- 33 Article using counted cross stitch
- 34 Article with line stitch

- 35 Article using long or short stitch
- 36 Any other project-related item

PATTERN#3
Horsemanship V (Western)

Dept JJ Division 27 OUTDOOR ADVENTURE (5,3,2)

Division 27A Hiking trails

1. Examples of items to pack in a backpack for a day hike (can be pictures)
2. Exhibit showing comparison of quality hiking or camping equipment
3. Exhibit on hiking safety
4. Exhibit explaining GPS use for hiking and geocaching
5. Journal and photos of a hike and/or camping trip you completed
6. Any other project related item

Division 27B Camping Adventures

1. Examples of items to pack in a backpack for an overnight hike (can be pictures)
2. Exhibit showing comparison of quality camping equipment
3. Exhibit on camping safety
4. Eight or more recipes used while camping
5. Exhibit showing knot tying and or tool use
6. Exhibit showing how to choose a camp site and or appropriate camp shelters
7. Journal and photos of a camping/hiking trip you completed
8. Any other project related item

Division 27C Backpacking Expeditions

1. Exhibit of items needed for an extended backpacking trip (Can be pictures)
2. Exhibit or outdoor survival skills and/or first aid
3. Ten or more recipes used while backpacking and camping
4. Exhibit showing how to use maps and/or compass or GPS
5. Exhibit showing Leave No Trace Principles
6. Exhibit showing how to purify water
7. Journal and photos of a backpack and/or camping trip you completed
8. Any other project related item

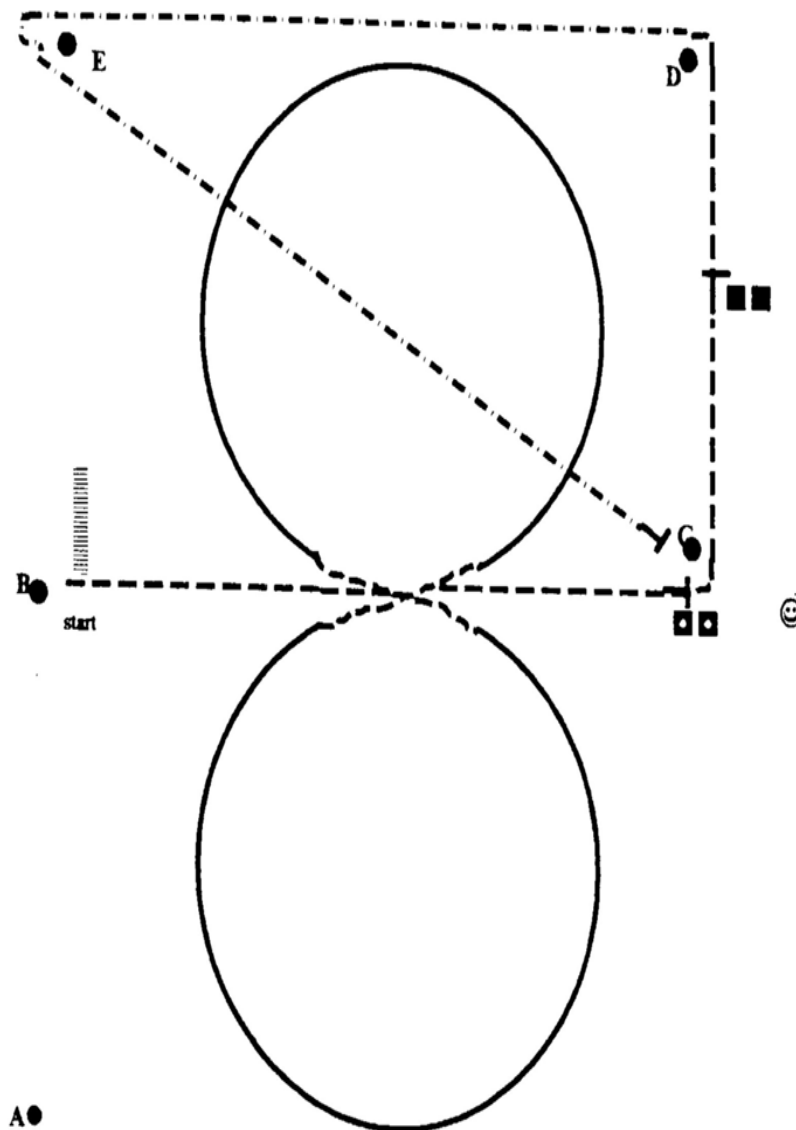

Division 6E -Level V

Class

1. Perform any tasks in Levels I, II, III and IV.
The horse will be judged on his ability to perform Pattern #3.

PATTERN #3

1. Start at marker B. Side pass to the left and right, 10 feet each way.
2. Jog to center. Pick up left lead to start figure 8 with a simple lead change in the middle.
3. After completion of figure 8 jog to judge and stop. Settle. Do a 180° hindquarter pivot right and left.
4. Jog around marker C halfway to marker D and stop. Do a 180° forehand turn right and left.
5. Jog to corner around marker D. Extend trot to and around marker E and to marker C. Stop.

DEPT NN Division 28 – PHOTOGRAPHY (Points 5, 3, 2)

- Hints for preparing fair entries for the photography project:
- Do your titling on lightly-ruled lines which can be erased later.
- Even-spacing around prints on the mount is very important.
- Do a good job mounting the pictures using rubber cement. Be sure to coat both surfaces and allow time for the cement extending beyond the edges of the pictures to dry, then it will rub off.
- Be sure the poster board you use for mounting is heavy enough.
- All photography exhibits should include a written explanation of your picture exhibit and what you learned.
- Each lot should be mounted separately. Each exhibit winning best of class in Units 1, 2, & 3 and Photography trophy winner is eligible to advance to the Champion of Champions Contest at the Eastern Montana Fair.

CAMERA TYPE NOT RELEVANT

Division 28A -Unit 1 Focus on Photography

Class

- 1 Poster with 8 or more parts of camera labeled
- 2 Outdoor pictures at different times of day. Use the same scene. (3 or more pictures)
- 3 Photos of shadows(3)
- 4 lightning (front back side and top lightning) Label each type of lightning(4)
- 5 Using flash (3ft, 5ft, 12ft) (3)
- 6 Fill flash (2)
- 7 Composition: horizontal picture with labeled foreground, middle-ground and back ground
- 8 Photos at different distances close-ups medium and long shots(at least one of each)
- 9 Trick pictures (3)
- 10 Black and White photos (3)
- 11 Scrapbook pages of pictures you took.
- 12 Photo story (3 to 10 pictures)
- 13 Any other project-related item

Division 28B -Unit 2 - Controlling the Image

Class

- 1 Short and long depth of field (at least 1 of each)
- 2 Low light(3)
- 3 Hard and soft light (at least 1 of each)

- 4 Silhouettes (2 or more)
- 5 Using flash (2 or more)
- 6 Rule of thirds (2 or more)
- 7 Golden triangle and golden rectangle (at least 1 of each)
- 8 Different view points (3 or more)
- 9 Photo story (3 to 10 pictures)
- 10 Use shutter speeds to show action (3 or more)
- 11 Show bits and pieces of subject (3)
- 12 Scrapbook page of pictures you took
- 13 Any other project related item

Class 28C-Unit 3 Mastering Photography

Class

- 1 Lenses - 3 pictures of the same scene using normal wide and telephoto lenses
- 2 Special effects using filters (3 or more)
- 3 Exposure : (1 overexposed 1 under exposed 1 balanced exposure)
- 4 Photos without flash using natural or artificial light (3 or more)
- 5 Reflections as subjects (2 or more)
- 6 Composition: framing the subject lines that lead the eye (1 or more of each)
- 7 Still life (3)
- 8 Portraits (2 or more)
- 9 Use color as a composition tool (3 or more)
- 10 Photos showing texture patterns or shapes (3 or more)
- 11 Photos showing interesting details (3)
- 12 Photos that could be used in a brochure (3 or more)
- 13 Any other project-related item

Division 28D -Unit 4 - Videography

Class

1. Short – 1-2 minute film
2. Long – 5 minute film
3. Public Service Announcement (PSA)
4. Storyboard and/or script for film production
5. Podcast of Video created
6. Research on topic for film creation
7. Filmed Interviews on specific topic

Division 28 NN Misc. Odds and Ends

- This division is open to all 4-H member entered in any level of photography Camera Type not relevant

**PATTERN #2
Horsemanship IV (Western)**

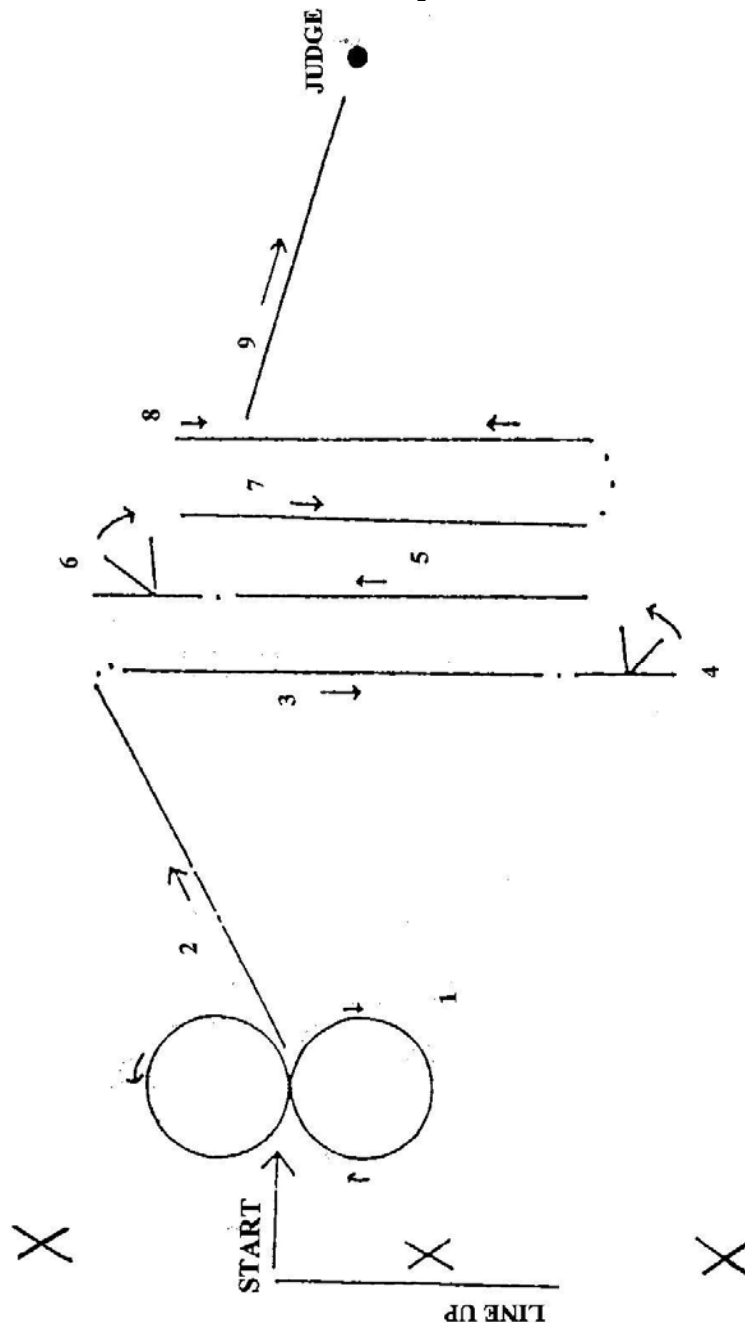

PATTERN #2

1. Make two figure eights at a lope, with a simple lead change (drop to a trot) - start with right lead.
2. Go to one end of the arena. Walk a straight line.
3. From a standing start, lope to the other end of the arena.
4. Make a rollback toward the judge.
5. Come out of the rollback at a lope to the other end of the arena.
6. Again rollback toward the judge.
7. Come out of the rollback smoothly at a lope.
8. Make a smooth stop in the center of the arena and then back the horse 15 feet in a straight line.
9. Move forward to the judge for final instructions.

- Division 27G1 Color
- Division 27G2 Black and White
- Division 27G3 Color enlargements
- Division 27G4 Black and white enlargements
- Division 27G5 Computer enhanced (attach original photo)

Class

- 1 Action
- 2 Agricultural
- 3 Animal or animals
- 4 Baby or babies
- 5 Carter County views (3)
- 6 Character study
- 7 Christmas card scene
- 8 Clouds
- 9 Collage or layered
- 10 Farm scene
- 11 Flowers
- 12 Interior
- 13 Outdoor architecture-new
- 14 Outdoor architecture-old
- 15 Picture story (3)
- 16 Portrait animal
- 17 Portrait child
- 18 Portrait adult
- 19 Ranch scene
- 20 Sunrises
- 21 Sunsets
- 22 Child or children
- 23 Humorous
- 24 Landscape
- 25 Night
- 26 Patriotic
- 27 Person or persons
- 28 Rainbow
- 29 Seasons (Picture of same subject/different seasons) 3-4 pictures
- 30 Wild animals, natural habitat
- 31 Photo Calendar (Using photos you have taken)
- 32 Action in Sports
- 33 Carter County Fair
- 34 Fireworks

- 35 Rodeo
- 36 Any other identify

PATTERN # 1
Horsemanship III (Western)

DEPT KK Division 29 - POCKET PETS (Points 4, 2, 1)
Division 29A -Level I - Pet Pals

Class

- 1 A display or scrapbook with pictures of different pets and at least two interesting facts about each pet
- 2 A poster about hazards to pets in our homes
- 3 A poster about plants that can be harmful to pets if eaten
- 4 A toy you have designed and made for a pet
- 5 A poster comparing prices of pets and supplies for three different kinds of pets
- 6 Educational display on commercial pet foods (label type and main ingredients)
- 7 A poster with two drawings of your pet (one with internal parts labeled and one with external parts labeled)
- 8 A set of at least two sketches you have made of your pet
- 9 Project manual
- 10 Any other project-related item

Division 29B -Level II - Scurrying Ahead

Class

- 1 A poster of the digestive system of a hamster identified and labeled
- 2 Poster of internal anatomy of your pet (label and specify function of each part)
- 3 A collection of photographs you have taken of pets (write your interpretation of each picture)
- 4 List and describe at least 20 animal related careers
- 5 An advertisement of a pet product or service (this ad is your creation from your own design)
- 6 Project manual
- 7 Any other project-related item

Division 29C -Level III - Scaling the Heights

Class

- 1. A plan you have developed for organizing your own business
- 2. A poster of your classification of four species of animals (include species, genus, family, order, class, phylum and kingdom)
- 3. A set of cards you have created to teach interesting pet facts

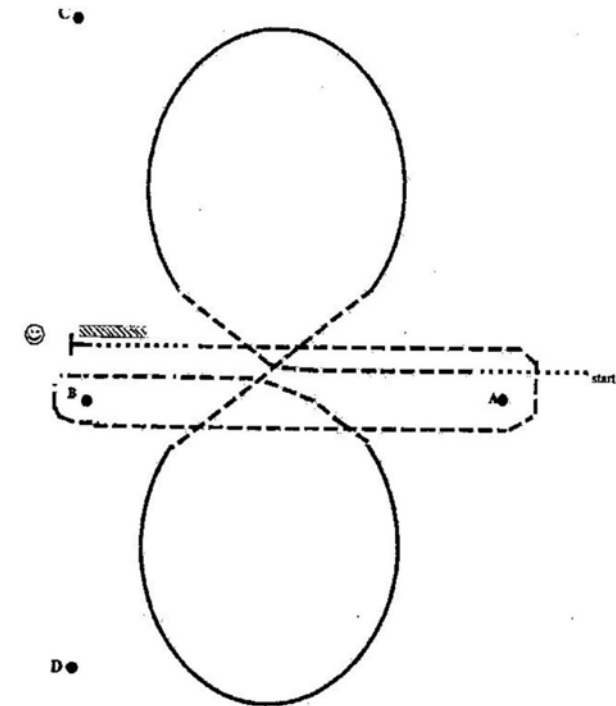

Division 6D -Level IV

Class

- 1. Contestants will be judged on their ability to perform Pattern #2 and perform any tasks in Levels I, II, and III.

- Demonstrate how to pick up all four feet
- Perform pattern #1 at the discretion of the judge

PATTERN #1

1. Walk to marker A. Pick up jog to middle of arena. Pick up right lead and lope circle near center of arena break to a jog. Jog through center of arena then pick up a left lead and lope a circle.
3. After completing left circle jog to and around markers B and A
4. Continue jogging towards judge. When near judge slow to a walk then stop. Settle horse. Back your horse 8 steps

4. A poster of diseases and symptoms for at least five species of pets (include treatment of diseases)
5. A poster of at least 20 specific situations with pictures that show people influencing animals or populations of animals
6. A short essay about your pet that you have written and illustrated
7. Project manual
8. Any other project-related item

DEPT AA Division 30 - POULTRY (Points 4, 2, 1) Division 30A -Level 1 - Scratching the Surface

Class

- 1 Twelve large grade AA eggs, white or brown
- 2 Poster identifying the parts of poultry
- 3 A collection of pictures and information on different species of poultry
- 4 A collection of pictures and information on different breeds of one species of poultry
- 5 Poster of a fresh egg you have drawn with the parts labeled
- 6 collection of five recipes for eggs using different cooking methods
- 7 A poster of your design for a brooding arrangement for 100 chicks (include measurements, floor space, ventilation, feeders, waterers, lighting and sanitation)
- 8 Collection of drawings or actual feathers with label of pattern & breed
- 9 Poster with the parts of a bird's digestive system labeled and at least one function of each part included
- 10 Project manual
- 11 Any other project-related item

Division 30B -Level 2 - Testing Your Wings

Class

- 1 Poster of a bird examination chart showing the difference between a healthy and an unhealthy bird
- 2 Poster of your drawing of a bird skeleton with at least 20 bones labeled
- 3 Chart with picture, names and functions of a hen's reproductive tract
- 4 Chart showing differences between a superior production hen and a non-laying hen
- 5 Poster with at least two poultry feed tag labels and feed tag information chart for each

- 6 An advertisement for a poultry product of your choice that you have designed yourself
- 7 A poster showing the results of your poultry product search (include a drawing of your favorite package)
- 8 A homemade candler with a description of how it works
- 9 A poster depicting a plan you have developed for preventing poultry diseases
- 10 Project manual
- 11 Any other project-related item

Division 30C -Level 3 - Flocking Together

Class

1. Details of a poultry judging clinic you have planned, organized and carried out (include pictures)
2. Your outline of a plan for managing a small laying flock
3. A prepared and mounted chicken skeleton
4. Your outline of steps to reduce food-related illnesses
5. A game you have created to educate the players about poultry
6. A collection of eggs dyed with natural dyes (label each egg with the dye material(s) used)
7. A drawing and explanation of a super bird you would like to create using biotechnological principles
8. A list and description of poultry related careers
9. Project manual
10. Any other project-related item

DEPT FF-Division 31 -QUILTING, PATCHWORK, APPLIQUE (Points 5, 3, 2)

These Classes may be entered by those enrolled in the quilting project

Class

- 1 Tote bag with patchwork pocket
- 2 Pot holders (2)
- 3 Place mats(2)
- 4 Table runner
- 5 Wall hanging using patchwork, tied
- 6 Christmas decoration
- 7 Christmas stocking
- 8 Simple patchwork pillow

indicated in class description. Chain chin straps less than one-half (½) inch in diameter are also prohibited. Split or Romal reins are permissible, but roping reins are not allowed. Spurs are optional. Spurs should not be used forward of the cinch. In all divisions, the judge has the option of requesting one or all contestants to perform individually.

HORSEMANSHIP (Points 7, 4, 2)

Refer to Introduction to Horsemanship Manual I-III, 5246 and Montana 4-H Horsemanship Project Manual, C1160

Showmanship refer to page 132

Division 6A -Level I

Class

1. The horse will be judged at a walk, trot and canter both ways of the ring. One or more contestants may be asked to dismount and mount.

Division 6B -Level II

Class

1. The horse will be judged at a walk, trot & canter, both ways of the ring using correct lead. One or more contestants may be asked to:
 - Perform any tasks in Level I
 - Back your horse six steps, while mounted
 - Name the parts of the horse and/or tack
 - Demonstrate the left and/or right lead
 - Move from a walk to a trot to a lope back to a trot then a walk both directions

For All Working Patterns

- The arena or plot should be approximately 50 x 150 feet in size.
- The judge will indicate where the mandatory markers are to be placed on the fence or arena wall.
- Large "X" indicates where mandatory markers are to be placed.

Division 6C -Level III

Class

1. The horse will be judged at a walk, trot and lope both ways of the ring using the correct lead. Trot or lope in a straight line around a pylon without breaking gait, return in a straight line and back your horse 10 steps while mounted. One or more contestants may be asked to:
 - Perform any tasks in Levels I and II

- Major faults - nervous, jiggling
- Disqualification - not walking

Jog:

- Good - easy riding, good motion, consistent, steady
- Minor faults - too slow, too fast
- Major faults - not performing a two-beat jog, failing to jog both front and back, hard or rough riding
- Disqualification - constant breaking

Lope:

- (Cannot extend)
- Good - easy riding, good motion, consistent, steady
- Minor faults - too slow, too fast
- Major faults - wrong lead, pulling, trotting behind, hard or rough riding
- Disqualification - Not under control

Extended Jog:

- Good - easy riding, good motion, smooth, consistent
- Minor faults - inconsistent speed
- Major faults - breaking gaits, pulling, hard or rough riding
- Disqualification - no increase in speed

Back:

- Good - proper flexion, readily responsive, back in straight line
- Minor faults - hesitant, not backing straight
- Major faults - throwing head, gaping, pulling
- Disqualification - not backing, rearing

General:

- Good - smooth, steady, easy riding, proper flexion and balance, good attitude
- Minor faults - over or under flexion, switching tail, inconsistent speed, out of balance, poll too high or too low to throw horse out of balance, improper or incomplete appointments
- Major faults - throwing head, bad mouth, constant bumping the bit, gaping, evidence of altered tail carriage, obvious schooling
- Disqualifications - constant breaking of gaits, two hands on reins unless using a snaffle bit or hackamore (bosal), kicking, illegal equipment, lameness, cuing horse in front of cinch, fall of horse or rider

GENERAL REQUIREMENTS FOR RIDING DIVISIONS

Entries must be shown in a stock saddle. Tie-downs, martingales, and mechanical hackamore of any type are prohibited unless other-wise

- 9 Simple patchwork quilt, tied
- 10 Any other project related item
- 11 Sampler quilt, tied
- 12 Baby quilt, patchwork or appliqué
- 13 Appliqué wall hanging
- 14 Wall hanging, hand or machine quilted
- 15 Article or garment with appliqué designs
- 16 Quillow
- 17 Quilt, hand quilted
- 18 Quilt, machine quilted
- 19 Article or garment using patchwork, tied
- 20 Article or garment, hand or machine quilted
- 21 Poster on color wheels
- 22 Poster of chart for designing a quilt project
- 23 Appliqué techniques in quilting
- 24 Block design quilt, tied
- 25 Block design quilt, hand quilted
- 26 Block design quilt, machine quilted
- 27 Color study with only one design quilt
- 28 Garments using patchwork and /or appliqué design
- 29 Research cultural and/or historical background of appliqué and patchwork designs
- 30 Set of quilted placemats
- 31 A table runner
- 32 Quilt, strip piecing with no backing fabric
- 33 Article or garment, strip piecing with no backing fabric
- 34 Quilt, strip piecing using a backing fabric
- 35 Article or garment, strip piecing using a backing fabric
- 36 Rag quilt
- 37 Any other project related item

DEPT AA Division 32 - RABBIT (Points 4, 2, 1)

Division 32A -Level 1 - Hop to IT! And what's Hopping

Class

- 1 Collection of pictures and information on different rabbit breeds
- 2 A chart showing the uses of different rabbit breeds
- 3 Poster with your drawing of a rabbit with at least 15 body parts labeled
- 4 Display or poster identifying equipment used in raising rabbits
- 5 A homemade rabbit cage

- 6 A poster identifying the symptoms and treatments of three rabbit health conditions resulting from different parasites
- 7 A description of five nutrients a rabbit needs in its diet and why
- 8 A homemade rabbit nest box
- 9 Project manual
- 10 Any other project-related item.

Division 32B -Level 2 - A Jump Ahead

Class

- 1 List and description of careers that deal with rabbits or rabbit products in some way
- 2 A mobile carrying case for a rabbit you have designed and built
- 3 A homemade rabbit nest box (include building plans and reasons for the size and shape)
- 4 Examples of at least five materials that can be used for nest box bedding (include description of each)
- 5 A rabbit tattoo box you have built yourself
- 6 A chart comparing a recommended human daily diet to that of a rabbit
- 7 An example of two rabbit feed labels and a chart comparing their nutritional value
- 8 A growth chart of your rabbit or rabbits over a ten-week period
- 9 Project manual
- 10 Any other project-related item.

Class 32C -Level 3 - Leaps and Bounds

Class

1. A collection of pictures (can be drawn) and information on 40 different breeds of rabbits
2. Pictures and explanation of a rabbit skillathon you organized and conducted
3. Your rabbit breeding record that you designed and maintained
4. Pictures and explanation of a rabbit showmanship clinic you organized and conducted
5. A chart of the dominant and recessive genes of our rabbits and an explanation of how genetics is helping you to improve your herd
6. A collection of ten recipes using rabbit meat
7. A poster or report on the availability/interest of markets for rabbit products in the United States
8. A description of at least ten rabbit and animal related careers
9. Project manual
10. Any other project-related item

8. Horses may be released with permission of horse superintendent each evening after 8 pm and must return by 8 am each morning
9. Youth enrolled in Horsemanship 1-7 can have an alternate horse. If this alternate horse is used by another 4-H member or a family member they must be enrolled in different levels of Horsemanship. The 4-H member needing to use an alternate will be required to have a veterinary certificate stating that their horse is unable to compete.
10. All horses in showmanship will be shown on halters only.
11. Horses must be exercised each morning and night.

General Dress Code For All Divisions

Western:

- Long sleeved, button or snap, white or solid colored blouse or shirt (no contrasting colors can be present on the shirt)
- Western type pants
- Western boots and western type hat (felt or straw) or helmet
- Vests, sweaters and jackets are prohibited
- Chaps, gloves and ties are optional
- Spurs are optional unless otherwise prohibited
- Hair that is shoulder length or longer must be contained in a net or braid while showing in the project or showmanship classes

English:

- Hunt type - Hunt coat (red, pink or scarlet coats prohibited unless exhibitor has earned them as a member of a recognized hunt)
- Breeches
- Hunt boots
- Hard hat with leather-type-chin strap for hunter type divisions
- Stock, chokers, or ties required
- Gloves optional
- Hair that is shoulder length or longer must be contained in a net or braid.
- Note: English jackets and/or vests may not be worn in halter, showmanship bareback divisions. Solid-colored long-sleeved blouse or shirt appropriate with English attire must be worn.

WESTERN JUDGING CRITERIA

Walk:

- Good - ground covering, flat footed, good attitude
- Minor faults - slow, disinterested, not attentive

- Proper control must be maintained at all times.
- Once a member and goat has completed all before mentioned years and has passed assessments to the satisfaction of harness goat leaders, member may assess to drive a team of goats. Team must be reasonably matched in size and weight and capability.
- The show ring in order to prevent uncontrolled entrance or exit of the animal for safety reasons.
- In the event a trained goat or team is purchased, exhibitor must pass assessments and demonstrate full and complete knowledge of the Harness Goat project in front of goat leaders.
- The carts and harness will be judged on neatness and proper fit.
- All harness projects must be secured by June 1 of the current year.
- Two animals per class will be permitted. A second year goat maybe used as part of a team, after passing assessments of goat leaders and advisors. Team must be reasonably matched in size and weight.

Class

- 1 First year
- 2 Second year
- 3 Third year

DEPT AP DIVISION 6 - HORSES

1. All animals shown by 4-H members in 4-H divisions must be owned by the member or in partnership with immediate family or the member must have access to the horse June 1 through the county fair.
2. Stallions may not be shown in any divisions with the only exception being a yearling in the Horse Training Project.
3. One horse can be shown by two members if in different divisions in horsemanship divisions only.
4. Members must compete in the most advanced level they are taking.
5. Members must ride at only one level English and/or one level Western. If riding both Western and English, the levels can have a spread of not more than two levels.
6. A Hackamore means the use of only rawhide braided leather braided or rope bosal. It does not refer to a so called "mechanical hackamore". Exhibitors are not allowed to use a mechanical hackamore.
7. Showmanship, Bareback Equitation and Trail divisions will be open to all horse project members at the Fair. Members must use one of their project horses in these divisions.

DEPT KK Division 33 - RANGE MANAGEMENT (Points 5, 3, 2)

The Grand Champion Range exhibit and the Best of Division Beginning Range are eligible to advance to the Champion of Champions Contest at the Eastern Montana Fair.

Division 33A -Beginning Range

Class

- 1 Make a collage of four kinds of land - poster divided into four segments - each segment consisting of drawings or cut outs that describe the kind of land
- 2 Draw a food chain on a poster
- 3 Make a plant notebook showing through illustrations or actual plant parts the following: (a) Flowers - shown vs. grass (b) Stems - parts or rhizomes and stolons (c) Leaves - simple vs. compound, reination patterns, leaf arrangements (d) Roots - different types of
- 4 Any other project-related item
- 5 Any other project-related item

Division 33B -Unit I

Class

- 1 Completed project manual
- 2 Plant collection - at least five plants identified
- 3 Any other project-related item

Division 33C -Unit II

Class

1. Completed project manual
2. Plant collection - at least 11 plants - includes 5 plants from Unit I
3. Plant Press
4. Any other project-related item

Division 33D -Unit III

Class

- 1 Completed project manual
- 2 Plant collection - at least 28 plants - includes 11 from Unit II
- 3 Educational display of range plants showing five decreaseers, five increaseers, and five invaders
- 4 Educational display showing the importance of determining soil textures
- 5 Educational display showing livestock grazing and utilization, grasses, one grass - like, eight forbs, four shrubs
- 6 Any other project-related item

Division 33E -Unit IV

Class

- 1 Unit IV Range Management Reference Book, completed
- 2 Educational display showing range conditions
- 3 Educational display showing livestock grazing patterns and range-land utilization
- 4 Educational display showing the effects of over-grazing
- 5 Educational display of range-use planning including a 1-year plan for a ranch
- 6 Any other project-related item

Division 33F -Unit V

- 1 Youth range manual project outline and project report
- 2 Display or poster relating to project
- 3 Any other project related item

Dept JJ Division 34 ROBOTICS (Points 4, 2,1) Division 34A Robotics, Level1, Explorer

Class

1. Poster on a project-related topic
2. Notebook that may contain completed project activities
3. Educational display on a project related topic
4. Any other project related item

Division 34 B Robotics, Level 2, Probe

1. Poster on a project-related topic
2. Notebook that may contain completed project activities
3. Educational display on a project related topic
4. Any other project related item

Dept CC Division 35 - SCRAPBOOK (Points 4, 2, 1)

Any member or club can enter classes in Scrapbook division.

Rosettes are awarded to the best exhibit by a junior exhibitor and senior exhibitor.

Division 35A Sr. Division

Division 35B Jr. Division

Class

1. Member's journal

- 2 Goat competing for third or fourth year.
- 3 Goat competing for five years or more.

Division 5H -Obstacle Course

- Division is open to doe or wether goats
- Goat must also be entered in one of the other division
- Lead and halter or collar is permitted. If led with collar and lead, collar will not be touched; doing so will result in loss of points.
- Course will be timed to help ascertain the winner.
- All new goats will start as first year beginners.

Class

- 1 Beginner - members competing in obstacle for the 1st and 2nd year
- 2 Novice - members competing in obstacle for the third and fourth years
- 3 Novice Graduate - members competing in obstacle for the fifth year and more.

Division 5I -Goat Driving/Harness (7, 4, 2)

- The harness goat project is a multi-year project. The first year of the project, the exhibitor can take a kid in the harness kid division or first year.
- The second year the animal can come back as a harness yearling.
- The third and succeeding years, the goat is in the senior harness divisions.
- The exhibitor must begin with the first year project.
- The harness goats will be judged on the following: the level of the division should deal with the level of the goat, not its age.
- This division is open to doe or wether goats of all breeds, and in possession prior to June 1 of the current year.
- All goats must begin at First Year, regardless of age.
- Harness must not exceed 25% of adult goat weight.
- Advancement between the years must be approved by goat leaders for safety reasons.
- All equipment used on goats must be checked by leaders for safety, proper fit and cleanliness.
- If Pygmy Goats are being used, they must begin to be trained as a team beginning with first year.
- All carts, 2 wheel as well as 4 wheel are not to exceed 100 lbs. and must be in proper, clean and safe working order.
- Rider and goat must compete against many and all goats in their class.

- 4 Dam and offspring, any ages.

Division 5E -Pygmy Goat (7, 4, 2)

Class

- 1 Kid, doe or wether born the current year
- 2 Yearling doe
- 3 Mature doe
- 4 Dam-& offspring any ages.

Divisions 5F -Fiber Goats (7, 4, 2)

- This division is open to any breed of goat whose primary function is that of producing fiber.
- Horned goats are permitted, as fiber goats are judged on breed characteristics, and are shown by horn and chin while standing next to goat.

Class

- 1 Doeling under 6 months of age.
- 2 Doeling 6 months and under 1 year.
- 3 Doe 1 year and under 2 years
- 5 Doe 2 years and older
- 6 Dam and Daughter
- 7 Granddame, Dam, & Daughter.

Division 5G -Pack Goat Project (Points 7, 4, 2)

- 1 Division is open to doe or wether goats of any breed born prior to and in possession prior to June 1, of current year.
- 2 Goat must also be entered in one of the other division
- 3 Lead and halter or collar is permitted. If led with collar and lead, collar will not be touched; doing so will result in loss of points.
- 4 Course will be timed to help ascertain the winner.
- 5 Weight of packs and items not to exceed 25% of the weight of a “well conditioned” adult goat, and not to exceed 10% of the weight of a kid goat. Example: 10% of a kid goat weighing 35 lbs. By the current fair is 3.5 lbs. A well conditioned adult goat weighing 150 lbs can carry 37.50 lbs.
- 6 goat is to be lead in then stand while the packs or pack saddle is put on and loaded. (A helper in this area is permissible) then the goat will be led around the course

Class

- 1 Goat competing for first or second year.

2. 4-H Club scrapbook
3. Member’s 4-H scrapbook
4. Health scrapbook
5. Safety scrapbook
6. Community-service scrapbook

**DEPT JJ Division 36 - SELF-DETERMINED PROJECT
(Non livestock)(Points 5, 3, 2)**

This project is designed for members to create a project that is not currently recognized by the 4-H program. The Self-Determined project work should not be able to be achieved by taking any of the projects available to the 4-H Members at this time.

Class

- 1 Poster
- 2 Notebook
- 3 Scrapbook
- 4 Educational Display
- 5 Essay
- 6 Any other way of telling about project
- 7 Display of 2 project items
- 8 Display of 3 project items (items should compliment each other)
- 9 Any homemade item used in project (not a result of)

**DEPT AA DIVISION 37 – SHEEP (Points 4, 2, 1)
Division 37A -Sheep 1 - Lambs, Rams and You**

Class

- 1 Collection of pictures and information on different sheep breeds
- 2 Poster with your drawing of a sheep with at least 25 body parts labeled
- 3 A chart of at least ten different kinds of items that contain wool (Include the item, percentage of wool it contained and price)
- 4 A poster of at least ten sheep by-products, where they are found and their use
- 5 Poster or educational display on manufactured products that come from sheep
- 6 A poster teaching how to tell the age of sheep
- 7 Educational display of sheep grooming equipment (Include name and explanation)
- 8 Poster of your drawing and explanation of the ideal ewe lamb
- 9 A sheep examination chart for a healthy sheep and a sick sheep

- 10 A lambing supply kit (neat and labeled) you have put together
- 11 Project manual
- 12 Any other project-related item

Division 37B -Sheep 2 - Shear Delight

Class

- 1 A poster showing the life cycle of at least two different sheep parasites and how to treat them
- 2 Poster with your drawing of a sheep's digestive system (Include a brief description of what happens as the feed moves through each part)
- 3 A poster or notebook of at least ten health problems, their symptoms, and prevention or cure
- 4 A poster of at least 30 jobs or careers that are related to the sheep industry. Identify each in categories such as marketing, production, etc
- 5 Poster of the eight sheep production periods with correct management practices recorded in each period
- 6 A chart of the weekly price of market lambs over a two month period
- 7 A poster of a shelter you have designed for 20 sheep (Include dimensions of cabinets, waterers, etc)
- 8 A lamb meat cut game using pictures and names to match lamb cut, wholesale cut, and preferred cooking method
- 9 Using an actual feed tag, identify the feed ingredients and the nutrients they supply
- 10 Project manual
- 11 Any other project-related item

Division 37C -Leading the Flock

Class

- 1 A graph of local weekly market lamb prices, and leg of lamb prices for a six week period
- 2 A full explanation with pictures of a sheep related activity that you have planned and conducted
- 3 Brief explanation/description of at least 20 different careers in Animal Agriculture (a poster, notebook or index cards)
- 4 Different examples of marketing sheep products
- 5 Poster of a ewe's and ram's reproductive system drawn and labeled
- 6 Poster of five ewe breeds and five ram breeds (Include an explanation and picture of each)

Division 5B -Junior Dairy Goat (Points 7, 4, 2)

Junior classes consist of does under 24 months of age that are not in milk and have never freshened.

Class

- 1 Born prior to June 1 and under 6 months.
- 2 6 months and under 1 year
- 3 Dry does and under 2 years

Division 5C -Senior Dairy Goat (Points 7, 4, 2)

Senior divisions consist of does that have freshened or milked regularly including dry and precocious milkers.

Class

- 1 Yearling and under 2 years
- 2 2 years and under 3 years
- 3 3 years and under 4 years
- 4 4 and under 5
- 5 5 years and older
- 6 Dam & Daughter
- 7 Granddame, Dam and Daughter
- 8 Best udder in show

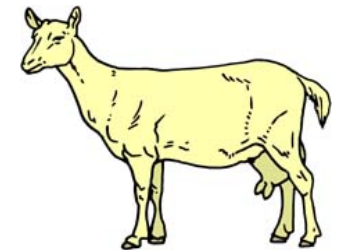

Division 5D -Meat Goat (Points 7, 4, 2)

- This division is open to any and all purebred and crossbred goats bred for meat.
- Some of the breeds include: Boer, Spanish, Cashmere, Kiko, Tennessee, Boer/Spanish, Spanish/Cashmere, Cashmere/Angora, Boer/Angora, and Pygmy.
- Although most any goat can be considered in the Meat Goat breeding project, the objective of this division is to show how you have improved the meat in your project. Any animal showing signs of disease, or improper abnormalities will be refused.

Class

- 1 Kid doe under 1 year of age
- 2 Yearling doe
- 3 Mature doe

DEPT AP DIVISION 5 - GOATS

- All goats should be clipped and clean before they are shown.
- All exhibitors will adhere to the official 4-H and FFA dress code.
- Members must have possession of their animals by June 1st.
- All animals must have scrapie ID tags
- All milking goats will be milked out 12 hours before show time.
- Collars are the only acceptable means under which goats may be shown.
- Animals must be shown in their respective Divisions before they are eligible to be shown in Dam & Daughter, Best Udder in Show and Best Junior Doe in Show.
- Dam & Daughter division will consist of biological dam and daughter. The objective in this division is to show you have improved on the conformation of offspring.
- Any animal showing signs of disease, emaciation, warts, ringworm, abscess (caseous lymphadenitis) or other skin conditions or unsightly blemishes will be refused.
- All animals must be completely healed from disbudding or dehorning. Horned goats may be shown by approval of goat superintendent. Also, the animals must be deemed safe and manageable by a leader or a committee member.
- No males will be shown. No males of breeding age (over 2 months) will be allowed on the fair grounds. If a male is castrated, they must be completely healed.
- All divisions are open to these breeds:

Saanen	Nubian Alpine	LaMancha
Toggenburg	Oberhasli	American
Experimental	Recorded Grade	

Showmanship refer to page 132

Division 5A -Market Goats (Points 7, 4, 2)

- Open to mixed or pure-breed goats born prior to June 1 of current year.
- Members must have possession of animals by June 1.
- Males must be castrated and completely healed.

Carter County 4-H & FFA Members Only in this Division

Class

- 1 Goat under 1 year
- 2 Pen of three (individual or club entry)

- 7 Poster or your drawing of the ideal sheep (Include where you would get the genetic material and list the characteristics of your genetically-engineered animal)
- 8 A poster showing your drawing of all the retail lamb cuts, their name and location
- 9 Project manual
- 10 Any other project-related item

DEPT JJ Division 38 - SHOOTING SPORTS (Points 4 2 1)

The judge will determine the most outstanding Shooting Sports Exhibit which will be eligible to advance to the Champion of Champions contest at the Eastern Montana Fair.

Divisions 38A -Rifles

Class

- 1 Poster on project related topic
- 2 Educational display on a project related topic
- 3 Notebook which could include project related activities
- 4 Scored targets in a notebook
- 5 Any other project-related item

Division 38B -Archery)

Class

- 1 Poster on project related topic
- 2 Educational display on a project related topic
- 3 Notebook which could include project related activities
- 4 Any other project-related item

Division 38C -Hunting

Class

- 1 Poster on project related topic
- 2 Educational display on a project related topic
- 3 Notebook which could include project related activities
- 4 Any other project-related item

Division 38D -Shotgun

Class

- 1 Poster on project related topic
- 2 Educational display on a project related topic
- 3 Notebook which could include project related activities
- 4 Any other project-related item

Division 38E Pistol

Class

1. Poster on project related topic
2. Educational display on a project related topic
3. Notebook which could include project related activities
4. Any other project-related item

Division 38F 22 Rim-Fire Rifle

Class

1. Poster on project related topic
2. Educational display on a project related topic
3. Notebook which could include project related activities
4. Scored targets in a notebook
5. Any other project-related item

Division 38G Muzzle loading

Class

1. Poster on project related topic
2. Educational display on a project related topic
3. Notebook which could include project related activities
4. Any other project-related item

Division 38H Cowboy Action

Class

1. Poster on a project related subject
2. Educational display on a project related topic
3. Notebook which could include project related activities
4. Any other project related item

DEPT CC Division 39- SHORT TERM (Points 4, 2, 1)

- Short-Term project consists of any type arts or crafts that won't fulfill requirements in any other 4-H Project – county or state.
- Member must enroll in Short-term project to exhibit in this class at the fair.
- Members may exhibit no more than two entries of the same type of art or craft.
- A project information sheet must be attached to each entry.
- Judging will be based on quality of work best of division will be given to most outstanding item in each division (Jr. Sr.)

Division 39A Sr. Division

Division 39B Jr. Division

DEPT AP DIVISION 4 - DOG

- A current vaccination record must be attached to entry form or dog will not be allowed to show.
- Dogs are not to stay on the fairgrounds. Dogs are brought to the fairgrounds for the judging only, and then removed.
- The conformation of the dog is not considered, but only the ability to present the dog to the judge
- Dogs must be shown with proper lead and be groomed and clean.
- This division is open to all 4-H project dogs- mixed and pure breeds.

Showmanship refer to page 132

Division 4A Dog Obedience (Points 5, 3, 2)

- All done on leash of 8-10 ft in length
- Level you exhibit in is based on ribbon placing of past performance/s of your dog and yourself working together as a team, not the level you are enrolled in. Your dog leader will inform you what level you are to exhibit in prior to the fair.

Class

- 1 Beginner A
- 2 Beginner B
- 3 Graduate Beginner
- 4 Novice
- 5 Graduate Novice

Division 4B Dog Agility (Points 5, 3, 2)

- Level you exhibit in is based on ribbon placing of past performance/s of your dog and yourself working together as a team, not the level you are enrolled in. Your dog leader will inform you what level you are to exhibit in prior to the fair.
- Youth competing in this division must be signed up for the dog project

Class

- 1 Beginner
- 2 Elementary
- 3 Intermediate
- 4 Senior
- 5 Advanced



DEPT AP DIVISION 2 CAT (Points 5, 3, 2)

A current vaccination record must be attached to the entry form or the cat will not be allowed to show.

This division is open to all cats - mixed and pure breeds.

Cats are not to stay on the fairgrounds. Cats are brought to the fairgrounds for the judging only, and then removed.

Class

- 1 Cat, 3 months to 1 year, health and grooming
- 2 Cat, over 1 year old, health and grooming



DEPT AP DIVISION 3 - DAIRY COW (Points 7, 4, 2)

Animals in dairy divisions will be judged on size for age, dairy type, vigor, condition, and milk producing characteristics.

Dairy Animal Exhibits

	Heifers under 1 year	Over 1 year & under 2	Cow over 2 & under 3 yrs	Cow 3 & not over 4yr
Holstein	1	2	3	4
Jersey	5	6	7	8
Ayrshire	9	10	11	12
Guernsey	13	14	15	16
Brown Swiss	17	18	19	20
Milking Shorthorn	21	22	23	24
Crossbred	25	26	27	28

Crossbred must be dairy-bred cross

Class

- 29 Dairy cow and calf



© 2008 by The American Quarter Horse Association

Class

- 1 Art or craft item
- 2 Art or craft item
- 3 Art or craft item
- 4 Art or craft item
- 5 Art or craft item
- 6 Art or craft item
- 7 Art or craft item
- 8 Art or craft item
- 9 Art or craft item
- 10 Art or craft item
- 11 Any other project related item

DEPT JJ Division 40 - SMALL ENGINES (Points 4, 2, 1)

Class 40A -Unit I -Crank it up

Class

- 1. Poster with the external parts of a lawn mower labeled
- 2. Poster or educational display of the tools needed for proper maintenance and repair of small engines
- 3. poster or informative exhibit identifying different sources of power and the things that “run” on each power source
- 4. A chart showing the results of an experiment to determine the efficiency of different types of fabric used as a filter
- 5. poster or informative exhibit explaining steps and the results of an experiment to determine the importance of the engine cooling system
- 6. A poster or educational display on spark plugs
- 7. A poster or notebook listing various jobs and identifying the machines needed to complete each of these jobs
- 8. collection of pictures of machines that have engines used for “play” and identify how they are used: air, water, land, travel and toys
- 9. A safety poster about protective gear to hang in a small engine work area
- 10. poster showing the results of your tool comparison
- 11. Project manual

Division 40B -Unit II - Warm It Up

Class

- 1. A poster or educational display identifying the similarities and differences among different types of small engines

2. poster or educational display identifying internal small engine parts
3. A poster or educational display identifying specialty tools used for maintenance and repair of small engines
4. A poster or notebook where you have determined the size of at least two engines by calculating the piston displacement
5. The steps and results of a compression test on a small engine and compare compression ratio of diesel and gasoline engines
6. A chart explaining the results of different oil grades being tested for viscosity under different conditions
7. A model of an engine that shows how the power is taken from the piston to the rest of the engine through the use of pulleys, belts, gears and other engine parts
8. A poster showing the correct procedure for storing your engine at the end of the season
9. A poster of the pre-mowing procedure to be hung up in a work area.
10. A notebook show the results of your research into exploring the possibilities of starting a lawn mowing business
11. Project manual.

Division 40C -Lawn and Power Equipment

Class

1. A poster or educational display identifying and explaining the use of diagnostic tools used in small engine repair
2. A notebook explaining the steps and your observations as you tear down the air and fuel system of a small engine
3. A notebook explaining the steps and your observations as you tear down the electrical system of a small engine
4. A notebook explaining the steps and your observations as you disassemble the engine base of a small engine
5. A poster or notebook with information on laws and regulations concerning small engines
6. Constructed go-cart, log splitter or other piece of equipment with a small engine you have selected for it.
7. A notebook listing and explaining the estimated costs and income of starting your own business using small engine equipment
8. Project manual

Division 1C -Beef Breeding Stock (Points 7, 4, 2)

- Beef-breeding animals must be in member's possession by June 1
- First place of each division will remain in the ring for Best-of-Breed judging. Best of each breed will return for overall-female champion at the end of the judging.
- Beef dairy cows will qualify for Crossbred female
- Only purebred animals can be entered as exhibits in classes 5 - 48

	Yearling	2 yr old with calf	3 yr old with calf	4 yr & over with calf
Hereford female	1	2	3	4
Black Angus female	5	6	7	8
Red Angus female	9	10	11	12
Charolais female	13	14	15	16
Tarentaise	17	18	19	20
RX3	21	22	23	24
Limousin	25	26	27	28
Gelbvieh	29	30	31	32
Simmental	33	34	35	36
Saler	37	38	39	40
Polled Herford	41	42	43	44
Maine Anjou	45	46	47	48
English Crossbreed	49	50	51	52
Exotic Crossbreed	53	54	55	56
Other	57	58	59	60

The top breeding yearling heifer in each breed is eligible for the overall heifer trophy.

Top cow/calf pair in each breed is eligible for the over-all cow/calf trophy

The age of the calves accompanying the cows for the cow with calf exhibits must be born after January 1 of current year

PLEASE NOTE: There is no bull to be shown in 4-H unless shown as a calf when accompanying the mother in one of the divisions.

DEPT AP DIVISION 1 - BEEF

Division 1A -Market Beef (Points 7, 4, 2)

- This division is open to any beef breed or crossbreeds.
- Animals must have been owned and fed by the exhibitor since Jan. 1,
- No milk in any form shall have been fed to the animals 90 days prior to the showing.
- The Carter County Grand Champion Market Beef animal and the Reserve Champion Market Beef animal are eligible to compete in the Champion of Champions contest at the Eastern Montana Fair.

Carter County 4-H & FFA Members Only in this Division

Showmanship refer to page 132

Class

1. Market Beef
2. Pen of three market beef. Entry can be individual or a club.

Division 1B - Junior Stocker-Feeder Beef Calves (Points 7, 4, 2)

- open to members enrolled in the Junior Stocker-Feeder Beef project
- Entries are limited to steers and heifers
- Calves must be on fairgrounds by 9:00 a.m. Saturday, and not leave until 6:00 p.m. Saturday
- For additional rules, etc., refer to project guidelines

Class

1. Stocker-Feeder Steers (born 2-1 to 4-15, of current year)
2. Stocker-Feeder Heifers (born 2-1 to 4-15, of current year)

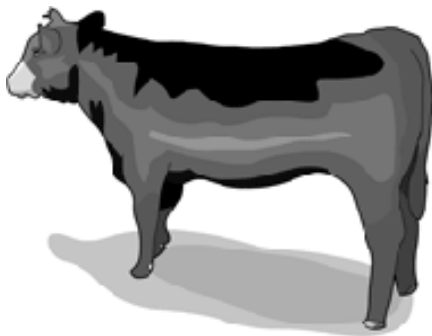

© SIMPLIS TECHNOLOGIES, INC.
ARTIST.COM

DEPT JJ Division 41-SPORTFISHING (Points 4, 2, 1)

Division 41A - Take the Bait

Class

1. Poster on project related topic
2. Notebook that may contain completed project activities
3. Educational display on a project related topic
4. Your tackle box and an inventory list of contents
5. Any other project-related item

Division 41B - Reel in the Fun

Class

1. Poster on project related topic
2. Notebook that may contain completed project activities
3. Educational display on a project related topic
4. A fly wallet constructed by member containing at least one artificial fly made by member
5. Any other project-related item

Division 41C - Cast into the Future

Class

1. Poster on project related topic
2. Notebook that may contain completed project activities
3. Educational display on a project related topic
4. A collection of artificial lures and/or flies made by member
5. Any other project-related item

DEPT AA Division 42 – SWINE (Points 4, 2, 1)

Division-42A -Level 1 - Growing with Swine and Squeal Appeal

Class

1. A collection of pictures and explanations of at least eight swine breeds
2. A Mix-and-Match Pig Game you have made
3. A picture of a pig you have drawn with at least 20 parts labeled
4. A complete budget you have prepared of the costs involved to buy a bred gilt and raise 10 pigs to market weight (Average 260 pounds)
5. Your drawn plan for a swine finishing facility
6. A drawn picture of a pig's digestive system with the parts labeled
7. A poster or educational display of at least 10 pork-by-products

- 8 Poster or notebook of at least 10 pork cuts (Include name, location, and preferred types of cooking)
- 9 A poster or educational display that identifies and names the primary uses of five swine feed ingredients
- 10 Project manual
- 11 Any other project-related item

Division 42B-Level 2 - Hamming it up

Class

- 1 A complete pig examination chart of a swine you own or have observed
- 2 A poster or notebook of at least ten swine diseases, their symptoms and how each can be treated
- 3 A poster of at least 30 jobs or careers that are involved bringing pork to your table
- 4 A poster of a health care plan for both pigs and gilts
- 5 poster of the nine swine production periods and an explanation of each
- 6 A poster of a complete ration for a growing pig (Include ingredients, percentages, and cost)
- 7 A sketch of your ideal pig and an explanation of why
- 8 Poster or educational display of swine equipment
- 9 Poster illustrating and explaining each of the four baby pig management practices
- 10 Project manual
- 11 Any other project-related item

Division 42C-Level 3 - Going Whole Hog

Class

- 1 Report on what you believe the swine industry will be like in five years
- 2 Pictures and explanation of a swine judging clinic you planned and conducted
- 3 Pictures and explanation of a swine showmanship clinic you have planned and conducted
- 4 Pictures and explanation of a swine quiz bowl you have written questions for, planned and conducted
- 5 A report on two state or national swine organizations you have contacted
- 6 A sketch of the house and farm you would like to own someday (Include notes on activities, equipment and landscape)

13. All members must dress appropriately for their livestock divisions. All divisions require neat clothing; pants and appropriate shirts. It is suggested that long sleeved white or pastel colored shirts, dark jeans, dark tie and work shoes be worn. Western hats and boots are required in the horse divisions heavy footwear is required in all other large livestock divisions. Shirts with writing, baseball caps, tennis shoes, sandals and thongs ARE NOT ALLOWED.
14. All animals may be removed between 5 p.m. and 1 hour after the rodeo concludes on Sunday. Each member must show a Livestock Superintendent his clean stall before leaving.
15. Montana 4-H and FFA require that animals be handled in a proper and ethical manner in accordance with accepted modern animal husbandry and scientific practices. In addition, adequate care, including watering, feeding and comfort should be appropriately provided to all animals. Any individual treating an animal in any other manner may be asked to leave the grounds.
16. Exhibitors, their parents, leaders and instructors have a serious responsibility to follow animal health practices that are approved by the industry and the U.S. Department of Agriculture to assure that meat customers are receiving wholesome food. Health aids and other approved products should be used with care, according to prescribed practices, only when needed and in the correct amounts.
17. Montana 4-H and FFA require that market animals meet all the Food and Drug Administration regulations governing management and safety practices. Approved withdrawal times from health aids and growth stimulants must be followed. Animals that do not meet these standards will not be sold.
18. Exhibitors should seek competent professional advice if medical situations arise which are beyond their capabilities.



4-H AND FFA LIVESTOCK PROJECTS

General Livestock Rules

WEIGH IN TIMES

FRIDAY 8 TO 9 A.M. & 5 TO 6 P.M.

SATURDAY 8 TO 9 A.M.

1. The livestock exhibitor must be properly enrolled in the livestock project that he/she exhibits.
2. Only 4-H and FFA members will be permitted to care for their own 4-H and FFA animals on exhibit unless good reason is presented for the necessity of other arrangements.
3. Upon 4-H and FFA animals arrival on the fair grounds, 4-H and FFA members must have an active part in fitting and cleaning their animals for the show ring.
3. Only 4-H and FFA members are eligible to show their own animals.
4. 4-H and FFA members in the sheep projects are requested to clean and trim their sheep for the fair. NOTE: It is not necessary that sheep be blocked or that wool breeds be washed.
5. If you are a member who is in both 4-H and FFA you must choose at the time of the possession date which organization you wish to sell your animal under. The member is only allowed to sell one market beef, one market swine, one market lamb, one market goat, one market chicken, and one rabbit.
6. All Market Beef entries are required to have a Bill of Sale. The Bill of Sale must be turned in at the time of weigh in.
7. Market Divisions are open to Carter County 4-H & FFA members only
8. FFA and 4-H will show together and trophies will be awarded to overall champions. Sponsor will be joint.
9. All Market Animals receiving a ribbon in the Market divisions will be allowed to sell at the Fair Livestock Sale, regardless of the color of ribbon the animal received. Those showing market animals that do not belong to Carter County 4-H or FFA will not be allowed to sell their animals.
10. **Livestock Sale at 3:00 p.m. at the Fairgrounds on Saturday.**
11. Exhibitor numbers will be assigned by the Fair Secretary.
12. Livestock exhibitors are not permitted to use tranquilizers for livestock within 30 days prior to the fair. Any drug used at the fair must be administered by or under the direct supervision of a veterinarian

7. Design a hog operation for ten 30 pound pigs to be raised to 240 pounds
8. Project manual
9. Any other project-related item

Division 43 - THEATER ARTS (Points 4, 2, 1)

Division 43A - Play the Role

Class

1. Display of tongue twisters you made up
2. Scene you have written with directions indicating voice tone
3. Script you have written with flashback scenes
4. Photos of the clown character you created
5. Picture story you created for a script
6. Series of stage pictures for a story
7. Critic's review of a musical you reviewed
8. Any other exhibit related to project
9. Any other exhibit related to project

Division 43B - Become a Puppeteer

Class

1. Sock puppet you made
2. Rod puppet you made
3. Everyday found object puppet
4. Puppet character you built
5. Puppet stage you built
6. Any other exhibit related to project
7. Any other exhibit related to project

Division 43C - Set the Stage

Class

1. Costume you designed
2. Set you designed and built
3. Color wheel you designed
4. Play prompt book you created
5. Any other exhibit related to project
6. Any other exhibit related to project

DEPT JJ Division 44 - VETERINARY SCIENCE (Points 4, 2, 1)

Exhibitor will prepare exhibits from the unit enrolled in. Drawings can be observed in each unit book. Drawings can be colored, if desired. The judge will determine the most outstanding Veterinary Science Exhibit which will be eligible to advance to the Champion of Champions contest at the Eastern Montana Fair.

Division 44A -Veterinary Science Unit 1

Class

- 1 Complete Unit 1 book
- 2 Label parts of a free-hand drawing of eye
- 3 Label a free-hand drawing of pathway of impulse
- 4 Label parts of a free-hand drawing of lungs showing veins and aorta
- 5 Label parts of a free-hand drawing of a section of heart
- 6 Photographic exhibit of normal and abnormal characteristics of animals
- 7 Poster showing temperature, respiration, and heart rate changes under varying conditions
- 8 Display or poster showing disease preventive procedures by use of proper nutrition and other management decisions
- 9 Safety display or poster concerning handling of chemicals used in Animal Health and disinfection
- 10 Poster or display on immunization of animals
- 11 Project manual
- 12 Any other project-related item

Division 44B -Veterinary Science Unit 2

Class

- 1 Complete Unit 2 book
- 2 Drawing of three external parasites of cattle (Write on drawing control measures of each)
- 3 Label a free-hand drawing of cell and four bacterial shapes
- 4 On one drawing complete and explain life cycle of heel fly and round worm
- 5 Collect, mount and identify 3 poisonous plants
- 6 Project manual
- 7 Any other project-related item

Division 44C -Veterinary Science Unit 3

Class

- 1 Notebook or self-study activity
- 2 Display or poster relating to project
- 3 Project manual
- 4 Any other project-related item

DEPT CC Division 48- WRITING ARTS (points 4, 2, 1)

To exhibit in this category you must be currently enrolled in 4-H cowboy Poetry project there is only one level and it is self paced. Project books and records are not to be exhibited to be judged

Class

- 1 A poster showing what you have learned about cowboy poetry.
- 2 Display of a least 3 original poems written by you during the current year.
- 3 An educational display related to what you have learned about rhyme schemes or meter.
- 4 An educational display about some of the classic cowboy poets.
- 5 An educational display about Western culture or history, especially about your local area.
- 6 Display of examples of cowboy poetry you have found in your local library.
- 7 A photo story of your participation in a cowboy poetry gathering.
- 8 A photo story showing you teaching others to write and recite their own original poetry.
- 9 Any educational display related to what you have learned in this project.

9. Any other project-related item
10. Any other project-related item

Division 47C -Nailing it Together

Class

1. Project manual
2. Notebook on one carefully researched woodworking career
3. Notebook of wood projects (include patterns, cost, tools used, etc)
4. Educational display of four different types of joints
5. One pattern in three different sizes that you have enlarged yourself by drawing on a grid
6. Educational display or notebook on different types of hinges, hasps, and flush plates
7. Any other project-related item
8. Any other project-related item
9. Any other project-related item

Division 47D -Finishing Up

Class

1. Project manual
2. Design your own workshop (describe all of the tools to include in your ideal workshop)
3. A set of woodworking plans you have designed and made yourself
4. Educational display of six different types of joints
5. Notebook or poster identifying the names, uses and characteristics of various adhesives
6. A wood project that you have refinished
7. Wood vehicle using project manual plans
8. Hockey board using project manual plans
9. Step stool/chair using project manual plans
10. Toy dog using project manual plans
11. Door knocker using project manual plans
12. Any other project-related item
13. Any other project-related item
14. Any other project-related item
15. Any other project-related item

DEPT KK Division 45 - WEED SCIENCE (Points 5 3 2)

The Grand Champion Weeds exhibit is eligible to advance to the Champion of Champions Contest at the Eastern Montana Fair.

Division 45A -Unit I Weed Science

Class

- 1 Standard-size wooden plant press, constructed by exhibitor
- 2 Collection of 12 weeds (properly mounted and identified)
- 3 Written story on “Why I Think it is Important to Recognize Weeds and Control Them or Loss and Damage Caused by Weeds on Our Property”
- 4 Notebook or display on weed options you have chosen
- 5 Project manual
- 6 Any other project-related item

Division 45B -Unit II Weed Science

Class

- 1 Collection of 18 weeds (properly mounted and identified) (No duplication of Unit I.)
- 2 A map of your farm, an adjoining farm, roadside, block or area in which you live showing patches of problem weeds
- 3 Record, with specific details, of a visit to a patch of weeds while they were being sprayed
- 4 Short story on “How I Would Control a Patch of Perennial Weeds”
- 5 Notebook or display on weed options you have chosen
- 6 Project manual
- 7 Any other project-related item

Division 45C -Unit III Weed Science

Class

- 1 Collection of 20 weeds (properly mounted and identified) (No duplication of Unit I or Unit II)
- 2 Sample of five different crop seeds, with a sample of three kinds of weed seeds that are commonly found in each of them for a total of 15 weed seeds (Do not duplicate weed seeds)
- 3 Notebook or display on weed options you have chosen
- 4 Project manual
- 5 Any other project-related item

Division 45D -Unit IV Weed Science

Class

1. Collection of eight weeds known to be poisonous to livestock (Properly mounted and identified)
2. Notebook or display on weed options you have chosen
3. Project manual
4. Any other project-related item (Identify)

DEPT UU Division 46 – WILDLIFE CONSERVATION (Points 4, 2, 1)

- The judge will determine the most outstanding Wildlife Exhibit which will be eligible to advance to the Champion of Champions Contest at the Eastern Montana Fair.

DIVISION 46A – Level 1, The Worth of Wild Roots

Class

1. Poster on a project related topic
2. Notebook which could include project related activities
3. Education display on a project related topic
4. Nature Journal (pg. 13-14)
5. Make a diorama of a wildlife scene, wildlife tracks, or wildlife signs
6. Write a Wildlife Essay
7. Wildlife Experiments (pgs. 44-60)
8. Any Display Board or poster exhibit (p.39)
9. Any other project related exhibit

DIVISION 46B – Level 2, Living Wild in an Ecosystem

Class

1. Poster on a project related topic
2. Notebook which could include project related activities
3. Education display on a project related topic
4. Project Manual
5. Your Nature Journal
6. A house you made for wildlife
7. Your wildlife habitat plan
8. A birdbath or feeder you made
9. Your integrated pest management plan
10. Any display related to project

DIVISION 46C – Level 3, Managing in a world with You and Me

Class

1. Poster on a project related topic
2. Notebook which could include project related activities
3. Education display on a project related topic
4. Project Manual
5. Any other project related exhibit
6. Any other project related exhibit

DEPT JJ Division 47 – WOODWORKING (Points 5, 3, 2)

Each exhibit winning best of division in Skill Level I, Level 2, Level 3, and Level 4 is eligible to advance to the Champion of Champions contest at the Eastern Montana Fair.

Division 47A -Measuring Up

Class

1. Project manual
2. Tool identification and usage notebook (at least 10 hand tools)
3. Safety poster
4. Display of different types of wood
5. Poster teaching differences between hard and soft woods
6. Display of at least 10 different types of nails and screws
7. Display or poster identifying different types and grades of sandpaper
8. Any other project-related item
9. Any other project-related item
10. Any other project-related item

Division 47B -Making the Cut

Class

1. Project manual
2. Tool identification / usage notebook (at least 10 hand and 5 power tools)
3. Notebook on safety procedures to follow when using woodworking tools (minimum of 10 tools)
4. Notebook on woodworking careers
5. Poster showing the different types of fiberboard and plywood
6. Display of different types of wood and matching game of at least 10 types of wood
7. Educational poster or notebook on liquid finishers (paint, shellac, varnish, etc.)
8. Any other project-related item