

WAVES OF GLORY

A TRIBUTE TO OUR TROOPS

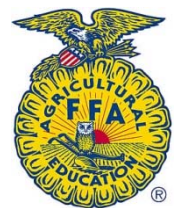

Fallon County Fair
August 18–22
2010





Welcome



To This Year's

Fallon County Fair

AUGUST 18 – 22, 2010

TABLE OF CONTENTS

FAIR SHOW SCHEDULE – PAGE 2

GENERAL RULES – PAGE 3

SILENT AUCTION – PAGE 4

4-H YOUTH INDOOR CLUB WORK

<u>DEPT.-DIVISION</u>	<u>PAGE</u>
UU.....1. Aerospace.....	5
WW2. Arts/Fine Arts.....	5
XX.....3. Beef.....	5
UU.....4. Bicycle.....	6
XX.....5. Cat.....	6
NN.....6. Child Development/Babysitting.....	6
NN.....7. Clothing & Textiles.....	7
JJ8. Cloverbuds.....	8
JJ9. Crop Science.....	8
XX.....10. Dairy Cow.....	9
XX.....11. Dog.....	10
UU.....12. Electricity.....	10
UU.....13. Entomology.....	11
JJ14. Exploring 4-H.....	11
NN.....15. Family Adventures.....	12
RR16. Food & Nutrition.....	12
JJ17. Forestry.....	15
XX.....18. Goat.....	15
NN.....19. Home Environment.....	16
XX.....20. Horseless Horse.....	16
KK.....21. Horticulture/Gardening.....	16
NN.....22. Leadership.....	18
UU.....23. Leathercraft.....	18
NN.....24. Needlework.....	19
UU.....25. Outdoor Adventure.....	20
TT.....26. Photography.....	20
JJ27. Pocket Pets.....	22
XX.....28. Poultry.....	22
NN.....29. Quilting.....	23
XX.....30. Rabbit.....	23
JJ31. Range Management.....	24
UU.....32. Robotics.....	24
WW33. Scrapbook.....	24
WW34. Self-Determined.....	25
XX.....35. Sheep.....	25
UU.....36. Shooting Sports.....	25
WW37. Short Term.....	26
UU.....38. Small Engines.....	26
UU.....39. Sportfishing.....	27
XX.....40. Swine.....	27
WW41. Theater Arts.....	27
XX.....42. Veterinary Science.....	28
JJ43. Weed Science.....	28
UU.....44. Wildlife Conservation.....	29
UU.....45. Woodworking.....	29
WW46. Writing Arts.....	30

Indoor Youth Awards.....Page 31

4-H/FFA YOUTH LIVESTOCK

Livestock RulesPage 32

<u>DEPT.-DIVISION</u>	<u>PAGE</u>
P1. Beef.....	34
P2. Cat.....	35
P3. Dairy Cow.....	35
P4. Dog.....	36
P5. Goat.....	36
<i>Horse Rules</i>	39
P6. Horse.....	40
P7. Self Determined (All Livestock).....	61
P8. Poultry.....	61
P9. Rabbit.....	62
P10. Sheep.....	63
P11. Showmanship.....	64
P12. Swine.....	65
P13. Wool.....	65

FFA YOUTH AGRICULTURAL EDUCATION INDOOR

<u>DEPT. DIVISION</u>	<u>PAGE</u>
U.....1. Ag Communication.....	66
U.....2. Livestock.....	66
U.....3. Plant Science.....	67
U.....4. Natural Resources.....	67
U.....5. Ag Processing.....	68
U.....6. Ag Mechanics.....	68

Special Youth Awards List 69

2009 Livestock Buyers 70

2009 4-H/FFA Award Contributors 71

FALLON COUNTY FAIR SHOW SCHEDULE

TUESDAY

Queen Contest

WEDNESDAY

- 6:00 am Horses may enter the barn
8:00 am All 4-H Horses must be in place
8:00 am Sr., Jr., Novice Horse Showmanship
Horse Riding Classes (see page 41 in fairbook)
10:00 am Trail Class to begin (to run concurrently with other horse classes)

~HORSES MAY BE REMOVED FROM THE BARN AND FAIRGROUNDS

AFTER SHOWING~

- 1:00 pm Goat Packing, Goat Harness, Goat Obstacle Course in that order
2:00 pm Sr., Jr., Novice Dog Showmanship
Dog Obedience
Dog Agility
Sr., Jr., Novice Cat Showmanship
Cat

THURSDAY

~EXHIBIT HALL CLOSED ALL DAY FOR JUDGING~

- 6:00 am Goats and Sheep may enter barn
8:30 am Goats and Sheep must be weighed and in place

~NO UNLOADING OR WEIGHING OF LARGE ANIMALS IN THE BARN FROM 8:30AM - 4:00PM~

- 9:00 am Sr., Jr., Novice Non-Fiber Goat Showmanship
Sr., Jr., Novice Fiber Goat Showmanship
Market Goat
Dairy Goat in fairbook order
Non-Dairy Breeding Goat in fairbook order
11:00 am Sr., Jr., Novice Sheep Showmanship
Market Sheep
Breeding Sheep Classes in fairbook order
1:00 pm Rabbits and Poultry in place

- 2:00 pm Sr., Jr., Novice Rabbit Showmanship
Market Rabbit
Breeding Rabbit Classes in fairbook order
Sr., Jr., Novice Poultry Showmanship
Market Poultry
Breeding Poultry Classes in fairbook Order
9:00 pm Beef, Dairy and Swine must be weighed (if applicable) and in place

FRIDAY

- 6:00 am Horses may enter barn
8:00 am All 4-H horses must be in place
8:00 am Sr., Jr., Novice Swine Showmanship
Market Swine
Breeding Swine Classes in fairbook order
10:00 am Sr., Jr., Novice Dairy Showmanship
Breeding Dairy Classes in fairbook order
1:00 pm Sr., Jr., Novice Beef Showmanship
Breeding Beef Classes in fairbook order
5:00 pm Market Beef
Breeding Beef will resume if not finished

SATURDAY

- 8:00 am Round Robin Showmanship
9:30 am Open Class Livestock Trailer Show
11:00 am Fallon County Fair Parade
1:00 pm 4-H Silent Auction Begins
12:30 pm Pet Parade
4:30 pm 4-H/FFA Youth Livestock Sale

SUNDAY

- 11:30 am 4-H Fair Awards Ceremony
3:00 pm All animals may be removed from the barn and fairgrounds
3:00 pm 4-H Silent Auction Bidding Closed
5:00 pm Demolition Derby
5:30-8:00 Indoor exhibits must be picked up

4-H GENERAL RULES

1. Members of 4-H Clubs in Fallon and Carter Counties are eligible to exhibit in this department. All members must be enrolled in the projects in which they are entering. All entries must be approved by the County Extension Agent or local club leaders.
2. All entries must be made on the Fallon County Fair entry blanks. Additional entry blanks are available at the Fair Office and the Extension Office.
3. Only one entry in each class per exhibitor except in rabbits and poultry when more than one type of breed is being exhibited.
4. No entry fee is required in this department.
5. Check fair schedule listed in County 4-H August newsletter for entry and exhibit-in-place deadlines for each specific project.
6. Attach "Age of Member, Year in Project", and year in current project level sticker to back of entry tags for exhibits in exhibit hall.
7. Exhibits need to be picked up at the Exhibit Hall between 6:00pm and 8:00pm on Sunday. 4-H members will not receive premium monies if they remove their exhibits from fairgrounds before Sunday at 6:00 p.m.
8. All 4-H exhibits will be judged on the Danish or Group System, of placing first group - blue, second - red, and third - white.
9. Posters must be no smaller than 14" X 22" and no larger than 22" X 28". Criteria for judging posters: Originality - 25% Neatness - 25% Content - 50%
10. Members who are enrolled in different levels of the same 4-H project are eligible to exhibit in the higher level only at fair time.
11. Entry forms must be turned into the Extension Office no later than Wednesday, August 4, 2010.
12. The Fallon/Carter Extension Service reserves the final and absolute right to interpret these 4-H rules and regulations and settle and determine all matters, questions and differences in regard to 4-H.

The point value equals \$1.00

4-H SILENT AUCTION

For Indoor Exhibits at the Fallon County Fair

1. Member must be enrolled in the project. Only one silent auction item per project, but member may enter one for each project they are enrolled in.
2. Item placed in the silent auction will be an entry in the fair. Item will be marked as such (for silent auction) on the fair entry form.
3. Silent auction item must have received a red or blue ribbon placing. If designated item does not receive a red or blue placing, another item may be selected from that member's other entries in that project that did receive said placing.
4. Member may require a minimum bid for their item.
5. Bids will be in increments of \$1.00
6. If the silent auction item is selected to go to Champion of Champions, a label will be on the item stating the situation to the bidders.
7. The location of the silent auction in the main exhibit hall will be at the discretion of the fairboard and manager; however, the location will be where the 4-H superintendents may observe the tables.
8. The auction will run from Saturday at 1:00 PM until Sunday at 3:00 PM. This will allow items to remain in their exhibit areas for a day following judging. A bright symbol placed on the entry tags of silent auction items will make it easier for location of items to place in the auction on Saturday.
9. At 3:00 PM on Sunday a Fallon County 4-H Leader will declare the bidding closed and announce the winning bidders for each item. Items are to be removed from the area by 5:30 PM Sunday. Payments will be made to the Fallon County 4-H Council and the treasurer will make out checks to the members. No deductions will be taken from the monies collected.
10. Items remaining after 5:30 PM on Sunday will be the responsibility of the member to deliver and collect money for. Likewise the checks will be made to the 4-H Council.

4-H YOUTH INDOOR CLUB WORK

DEPARTMENT UU

DIVISION 1 – AEROSPACE

DIVISION 1A – Aerospace Level 1 – Lift-Off (Points 4,2,1)

CLASS NO.

1. Poster on a project related topic
2. Notebook which could include project related activities
3. Education display on a project related topic
4. Any other project related item
5. Any other project related item

DIVISION 1B – Aerospace Level 2 – Reaching New Heights (Points 6,3,1)

CLASS NO.

1. Poster on a project related topic
2. Notebook which could include project related activities
3. Education display on a project related topic
4. Any other project related item
5. Any other project related item

DIVISION 1C – Aerospace Level 3 – Pilot In Command (Points 8,4,2)

CLASS NO.

1. Poster on a project related topic
2. Notebook which could include project related topic
3. Education display on a project related topic
4. Any other project related item
5. Any other project related item

DEPARTMENT WW

DIVISION 2 – ARTS/FINE ARTS

DIVISION 2A – Arts K – 6 (Points 8,4,2)

CLASS NO.

1. Item you have made incorporating cutting and pasting
2. Item you have made incorporating drawing
3. Item you have made incorporating painting
4. Item you have made incorporating sculpting
5. Item you have made incorporating printing

6. Item you have made incorporating fiber
7. Item you have made incorporating 3-D construction
8. Any other project related item

DEPARTMENT XX

DIVISION 3 – BEEF

DIVISION 3A –Beef 1–Bite Into Beef (Points 4,2,1)

CLASS NO.

1. Poster on a project related topic
2. Notebook which could include project related activities
3. Educational display on a project related topic
4. A collection of at least 10 labeled feed ingredients fed to beef cattle
5. Any other project related item

DIVISION 3B –Beef 2–On the Moove (Points 4,2,1)

CLASS NO.

1. Poster on a project related topic
2. Notebook which could include project related activities
3. Educational display on a project related topic
4. A collection of at least 10 beef by-products, telling from what part of the animal they are from and their uses
5. Any other project related item

DIVISION 3C –Beef 3–Leading The Charge

(Points 4,2,1)

CLASS NO.

1. Poster on a project related topic
2. Notebook which could include project related activities
3. Educational display on a project related topic
4. A rope halter you have made
5. Any other project related item



DEPARTMENT UU
DIVISION 4 – BICYCLE

Judge will determine most outstanding Bicycle Exhibit which will be eligible to advance to the Champion of Champions Contest at the Eastern Montana Fair.

DIVISION 4A – Unit 1 – You and Your Bicycle (Points 4,2,1)

CLASS NO.

1. Poster on a project related topic
2. Notebook which could include project related activities
3. Educational display on a project related topic
4. Any other project related item

DIVISION 4B – Unit II – Caring For Your Bicycle (Points 6,3,1)

CLASS NO.

1. Poster on a project related topic
2. Notebook which could include project related activities
3. Educational display on a project related topic
4. Any other project related item

DIVISION 4C – Unit III – Mastering Bicycle Skills (Points 8,4,2)

CLASS NO.

1. Poster on a project related topic
2. Notebook which could include project related activities
3. Educational display on a project related topic
4. Any other project related item

DEPARTMENT XX
DIVISION 5 – CAT

DIVISION 5A – Level 1 – Purrr-fect Pals (Points 4,2,1)

CLASS NO.

1. Poster on a project related topic
2. Notebook which could include project related activities
3. Educational display on a project related topic
4. Any other project related item



DIVISION 5B – Level II – Climbing Up! (Points 4,2,1)

CLASS NO.

1. Poster on a project related topic
2. Notebook which could include project related activities
3. Educational display on a project related topic
4. Any other project related item

DIVISION 5C – Level III – Cat Connections (Points 4,2,1)

CLASS NO.

1. Poster on a project related topic
2. Notebook which could include project related activities
3. Educational display on a project related topic
4. Any other project related item

DEPARTMENT NN
DIVISION 6 – CHILD DEVELOPMENT/
BABYSITTING

Judge will determine most outstanding Child Development project, which will be eligible to advance to the Champion of Champions Contest at the Eastern Montana Fair.

DIVISION 6A – Level 1 – Growing On My Own (Points 4,2,1)

CLASS NO.

1. Design a Bloomin' Bag
2. A collection of (10-12) pictures of you at different ages. Describe how you have changed on the outside and the inside.
3. A learning box with 10 or more items (labeled)
4. A notebook, poster, or card index describing 12 or more time out ideas or activities
5. A notebook listing the 12 roles of your life, the responsibilities of each role and the hat you would wear for each role
6. Your design of a Fire Escape Plan for your home and family
7. Notebook, poster or display related to this project
8. Any other project related exhibit
9. Any other project related exhibit

**DIVISION 6B – Level 2 – Growing With Others
(Points 6,3,1)**

CLASS NO.

1. Home alone game enlarged
2. A plan for when I'm home alone including a list of emergency telephone numbers
3. A collection of at least 10 recipes of nutritious snacks to make safely alone
4. A friendship chain
5. A family tree you have designed
6. Poster of the Food Guide Pyramid
7. Street smart game on a poster
8. A notebook, poster or display relating to this project
9. Any other project-related item

**DIVISION 6C – Level 3 – Child Development
(Points 8,4,2)**

CLASS NO.

1. A resume you have developed for a career working with children
2. A set of completed television evaluation forms for at least five shows aimed at children under the age of 6
3. A Friendship Quilt
4. A toy you have created for a specific age level (specify the age range)
5. An exhibit depicting a community service project you have planned and implemented
6. A notebook, poster or display illustrating basic first aid, CPR, and poison control emergencies
7. A first aid kit with explanation of use of items in the kit
8. A notebook, poster or display of activities available to youth in your community
9. A notebook, poster or display related to this project
10. Any other project-related item

DIVISION 6D – Babysitting (Points 8,4,2)

CLASS NO.

1. Poster on a project related topic
2. Notebook which could include project related activities
3. Educational display on a project related topic
4. A Babysitter's Magic Bag
5. Any other project related exhibit

DEPARTMENT NN

DIVISION 7 – CLOTHING AND TEXTILES

Judge will judge the entire exhibit for each of the following classes. Pattern envelope and instruction sheet should be exhibited with the garment. Each exhibit winning Best of Class in Skill Level I, Level 2, and Level 3 is eligible to advance to the Champion of Champions contest at the Eastern Montana Fair.

DIVISION 7A – Skill Level 1 – Sew and Have Fun (Points 4,2,1)

CLASS NO.

1. Educational display or notebook on a project-related topic
2. Hand-sewn item – either mended or item you have made
3. Sewing box with labeled equipment
4. Item with some type of casing
5. Item utilizing hand stitching
6. Item with trim
7. Item with finished seams
8. Item with buttons, snaps or hooks
9. Serged item using beginning sewing skills
10. Item sewn utilizing Level 1 Skills and made with wool
11. Stitch a card
12. Simple gathered skirt
13. Hair scrunchie
14. Item decorated with fusible web
15. Tote bag
16. Any other project-related item
17. Any other project-related item

**DIVISION 7B – Skill Level II – Sew Much More
(Points 6,3,1)**

CLASS NO.

1. Educational display, notebook, chart, or poster on a project-related topic
2. Any item with clipped curves
3. Item with darts
4. Item that has gathers
5. Item with a zipper
6. Item with machine button holes
7. Item using interfacing
8. Item with seams finished or utilizing different, i.e. Flat felled, French, etc.
9. Item with set in sleeves
10. Serged item using novice sewing skills
11. Item sewn utilizing Level 2 skills and made with wool.
12. Patchwork pillow

13. Simple apron
14. Simple pants
15. Simple shirt
16. Any other project-related item
17. Any other project-related item

DIVISION 7C – Skill Level III – Sew On and Sew Fourth (Points 8,4,2)

CLASS NO.

1. Project related educational item, display, poster, or notebook
2. A clothing item you have updated (include before picture)
3. Outdoor product created from polar fleece (include pattern)
4. Recreational gear: (hiking, bicycling, golfing) – For example: tent, sleeping bag, back pack or other recreational gear
5. Western wear: pants, jacket, shirt, coat or other western wear
6. Any item of outer wear: jacket or 1-piece snowsuit (down or synthetic insulation), vest (down or synthetic) or pants
7. 3-or-more piece ensemble with one garment purchased and the rest home sewn. Include price and care labels for purchased garment
8. Item with set-in sleeves
9. Striped or plaid garment
10. Lined garment
11. Item including interfacing
12. Item with pockets
13. Item with collar and/or cuffs
14. Top-stitched item
15. Serged item using advanced sewing skills
16. Item sewn utilizing Level 3 skills and made with wool
17. Any other project-related item
18. Any other project-related item

DIVISION 7D – Skill Level IV – Advanced Sewing Skills (Points 10,5,3)

CLASS NO.

1. Project related educational item, display, poster, or notebook
2. An original design created for yourself or someone else
3. An item with lining
4. An item or garment using interfacing in shaping

5. A formal or tailored garment
6. An item that masters bound button holes
7. An item with interfaced hem
8. An item with creative uses of embellishments
9. An item demonstrating expertise in working with at least two challenging fabrics (such as wool, satin, lycra, deep pile, metallic, brocade, sheers, leather or leather look-alike, stretch knit, etc.)
10. New garment made from a recycled garment, include before and after pictures
11. Any other project-related item
12. Any other project-related item

DEPARTMENT JJ

DIVISION 8 – CLOVERBUDS (1 Point)

Open to all Cloverbuds. Exhibits must be related to information in Cloverbud Manual and topics covered at Cloverbud meetings.

CLASS NO.

1. Animals - pets
2. Creative Arts
3. Clothing - fabric
4. Environmental education
5. Food and nutrition
6. Games
7. Horticulture education
8. Health and safety
9. Performing arts
10. Recipes
11. Science
12. Any other project related item

DEPARTMENT JJ

DIVISION 9 – CROP SCIENCE

DIVISION 9A – Wheat-Grower Helper (Points 4,2,1)

CLASS NO.

1. Display showing how to run germination tests
2. Display showing wheat at different stages of growth
3. Notebook, poster or display on some other aspect of your project
4. Any other project-related item

DIVISION 9B – Junior Wheat Grower (Points 6,3,1)

CLASS NO.

1. Poster or display on soil sampling and fertilization
2. Poster, notebook or display
3. One quart sample of threshed wheat
4. Any other project-related item

DIVISION 9C – Senior Wheat Grower (Points 8,4,2)

CLASS NO.

1. Notebook on your wheat production enterprises (up to where you are at). Include all production inputs and their costs. You may include an estimate of harvest costs, yields, and values, if you like; but use actual yields and costs for final records.
2. Poster, notebook or display on some other aspect of your project
3. Any other project-related item

DIVISION 9D – Practical Crop Production (Points 8,4,2)

CLASS NO.

1. Notebook on your production methods and costs
2. Educational poster or display on some aspect of your crop, such as production, storage, marketing, etc.
3. Samples of your crop at different stages of growth
4. Any other project-related item

DIVISION 9E – Barley-Grower's Helper (Points 4,2,1)

CLASS NO.

1. Poster or display related to project
2. Notebook on project
3. Collection of barley plants at different stages of growth
4. Display showing how to run a germination test
5. Any other project-related item



DIVISION 9F – Junior Barley Grower (Points 6,3,1)

CLASS NO.

1. Photo story of five varieties of barley as outlined on page 6, activity 2, of project book
2. Notebook which could include project related activities
3. One quart sample of threshed barley from project
4. Poster or display related to project
5. Any other project-related item

DIVISION 9G – Senior Barley Grower (Points 8,4,2)

CLASS NO.

1. Notebook which could include project related activities
2. Two food items utilizing barley flour
3. Poster or display related to project
4. Any other project related item

DEPARTMENT XX

DIVISION 10 – DAIRY

DIVISION 10A – Dairy 1 – Dig Into Dairy (Points 4,2,1)

CLASS NO.

1. Poster on a project related topic
2. Notebook which could include project related activities
3. Educational display on a project related topic
4. Any other project related item

DIVISION 10B – Dairy 2 – Mooving Ahead (Points 4,2,1)

CLASS NO.

1. Poster on a project related topic
2. Notebook which could include project related activities
3. Educational display on a project related topic
4. A collection of samples of different feeds or supplements for each of the nutrients a dairy cow requires
5. Any other project related item

**DIVISION 10C – Dairy 3 – Leading The Way
(Points 4,2,1)**

CLASS NO.

1. Poster on a project related topic
2. Notebook which could include project related activities
3. Educational display on a project related topic
4. Any other project related item

DIVISION 10D – Dairy Products (Points 4,2,1)

CLASS NO.

1. 1 quart of whole milk
2. 1 pint of fresh cream
3. 2 cups of unsalted, uncolored butter
4. A minimum of 8 oz. of any kind of cheese

**DEPARTMENT XX
DIVISION 11 – DOG**

**DIVISION 11A – Level 1 – Wiggles and Wags
(Points 4,2,1)**

CLASS NO.

1. Poster on a project related topic
2. Notebook which could include project related activities
3. Educational display on a project related topic
4. Any other project related item

**DIVISION 11B – Level 2 – Bounding Ahead
(Points 4,2,1)**

CLASS NO.

1. Poster on a project related topic
2. Notebook which could include project related activities
3. Educational display on a project related topic
4. Any other project related item

**DIVISION 11C – Level 3 – Pointing the Way
(Points 4,2,1)**

CLASS NO.

1. Poster on a project related topic
2. Notebook which could include project related activities
3. Educational display on a project related topic
4. Any other project related item



DEPARTMENT UU

DIVISION 12 – ELECTRICITY

The Grand Champion Electricity exhibit is eligible to advance to the Champion of Champions Contest at the Eastern Montana Fair.

**DIVISION 12A – Level I – Magic of Electricity
(Points 4,2,1)**

CLASS NO.

1. Any item made from the project manual
2. Any item made from the project manual
3. Notebook which could include project related activities
4. Poster or educational display on a project related topic
5. Any other project related item

**DIVISION 12B – Level II – Investigating
Electricity (Points 6,3,1)**

CLASS NO.

1. Any item made from the project manual
2. Any item made from the project manual
3. Notebook which could include project related activities
4. Any other project related item
5. Poster or educational display on a project related topic

**DIVISION 12C – Level III – Wired for Power
(Points 8,4,2)**

CLASS NO.

1. Any item made from the project manual
2. Any item made from the project manual
3. Notebook which could include project related activities
4. Any other project related item
5. Poster or educational display on a project related topic

**DIVISION 12D – Level IV – Entering
Electronics (Points 10,5,3)**

CLASS NO.

1. Any item made from the project manual
2. Any item made from the project manual
3. Notebook which could include project related activities
4. Any other project related item
5. Poster or educational display on a project related topic

DEPARTMENT UU

DIVISION 13 – ENTOMOLOGY

- The Grand Champion Entomology Exhibit will be eligible to advance to the Champion of Champions Contest at the Eastern Montana Fair.
- Exhibit will be judged on the following: Correctness of identification, variety of insects in collection, correctness and uniformity of pinning and labeling, condition of specimen, neatness and arrangement in the display box.
- A minimum of four orders of insects required.
- Notebooks will be judged on completeness.

DIVISION 13A – Level 1 – Creepy Crawlies (Points 4,2,1)

CLASS NO.

1. Educational poster or display
2. Notebook which could include project related activities
3. Any other project related item

DIVISION 13B – What’s Bugging You? (Points 6,3,1)

CLASS NO.

1. Poster or educational display
2. Collection of 20 different adult insects (1st year of Level 2)
3. Collection of 30 different adult insects (2nd year of Level 2)
4. Collection of 40 different adult insects (3rd year of Level 2)
5. Notebook which could include project related activities
6. Any other project related item

DIVISION 13C – Dragons, House and Other Flies (Points 8,4,2)

CLASS NO.

1. Poster or educational display
2. Collection of 50 different adult insects (1st year of Level 2)
3. Collection of 60 different adult insects (2nd year of Level 2)
4. Collection of 70 different adult insects (3rd year of Level 2)
5. Notebook which could include project related activities
6. Any other project related item

DEPARTMENT JJ

DIVISION 14 – EXPLORING 4-H

- The trophy will be awarded to the exhibitor with the most points based on 4,2,1 point system. If a tie results, the judge will select the trophy winner.
- All entries must be made by the exhibitor.
- Animals exhibited in Exploring 4-H will not be eligible to be sold during the Fair Livestock Sale.
- Judge will determine the most outstanding Exploring 4-H Exhibit which will be eligible to advance to the Champion of Champions contest at the Eastern Montana Fair.

DIVISION 14A – Unit 1 – Discovering 4-H (Points 4,2,1)

CLASS NO.

1. Montana information
2. Safety poster or display
3. Button sewn on an item
4. Snack recipe and sample of food item
5. Food pyramid guide poster
6. Poster or educational display
7. Horticulture exhibit
8. Collection of ten insects – identify with common name
9. Bird feeder
10. Item dealing with wildlife
11. Item dealing with animals and pets
12. Demonstration poster
13. Live animal (Notify Extension Office of the type of animal bringing)
14. Finished project manual
15. Display your treasure box
16. Display your Travel Log
17. Your scrapbook of 4-H information
18. Display your cards and your Happy Face or Favorite things to do lists
19. Any other project-related item



DEPARTMENT NN

DIVISION 15 – FAMILY ADVENTURES

(Points 4,2,1)

Any valuable items – make arrangements prior to fair to be judged and to take home following judging.

CLASS NO.

1. Poster on a project related topic
2. Notebook which could include project related activities
3. Educational display on a project related topic
4. Project Manual
5. Any other project related exhibit
6. Any other project related item

DEPARTMENT RR

DIVISION 16 – FOOD AND NUTRITION

- Members are encouraged to exhibit in their project area and in “Odds and Ends” food lots. Only one entry is allowed in each lot per exhibitor. Each 4-H member must make their own entries. Members of the same family should make different recipes. No packaged mixes may be used except as specified. Poster can be no smaller than 14”x 22”.
- Guides for display: Staple or tape entry tags on the outside of zip-lock bags. Write member’s age and year in project on entry tag. All baked goods must be placed in clear-plastic bags. Only use plastic wrap as a last alternative. All fruit and vegetables must be displayed on Styrofoam-meat trays or bowls, or heavy cardboard covered with foil. Small paper plates are to be used whenever possible to conserve space.
- Salads, dressings, butter, cheese, etc., can be exhibited in clear-glass jars.
- Perishable foods can be taken home after judging. Ribbons will be left for display on the tag. Other exhibits may not be removed until 5:30 p.m. Sunday.

DIVISION 16A – Beginning Foods (Points 4,2,1)

CLASS NO.

1. Display of measuring tools
2. Poster of food groups
3. Recipe file with a collection of at least 10 recipes from this area
4. Drop cookies (4)

5. ½ of a simple cake (your choice) on large meat tray
6. Monkey Bread, ½ of ring on large tray
7. Fun veggie display
8. Any other project-related item

DIVISION 16B – Six Easy Bites (Points 4,2,1)

CLASS NO.

1. Recipe file with a collection of at least 10 recipes
2. Granola bars (4) (include recipe)
3. Shaped or molded cookies (4) (include recipe)
4. Bar cookies (4) (include recipe)
5. Drop cookies (4) (include recipe)
6. Icebox or refrigerator cookies (4) (include recipe)
7. Colossal Chocolate Chunk Cookies (2) (include recipe)
8. Mystery Muffins (4) (include recipe)
9. Any muffin (4) (include recipe)
10. Quick bread loaf (include recipe)
11. Frozen cookies displayed in freezer bag or freezer container (6)
12. Frozen berries displayed in freezer bag or freezer container
13. Project manual
14. Any other project-related item

DIVISION 16C – Tasty Tidbits (Points 6,3,1)

CLASS NO.

1. Recipe file with at least 20 recipes
2. Educational display on how to freeze vegetables
3. Melon Boat fruit salad
4. Hot cocoa mix in storage container (include recipe)
5. Square, oblong or round layer of cake without frosting (include recipe)
6. No yeast Twisty Pretzels (4) (include recipe)
7. Rolled baking powder biscuits (4) (include recipe)
8. Dried banana chips in plastic bag or container
9. Frozen unbaked drop cookies in freezer bag or freezer container
10. Project manual
11. Any other project-related item

DIVISION 16D – You’re the Chef (Points 6,3,1)

CLASS NO.

1. Recipe file with at least 30 recipes
2. Educational report on anorexia and bulimia
3. ¾ loaf of non-yeast (include recipe)
4. ¾ loaf of yeast bread (include recipe)
5. Bread sticks (4) (include recipe)
6. Yeast rolls of any shape but not a sweet roll (4) (include recipe)
7. Fruit Leather (include recipe)
8. One container of freezer jam (include recipe and storing instructions)
9. One jar of fresh pack dill pickles (include recipe and complete instructions)
10. Package non-perishable invented snack. Exhibit must include a separate folder containing a marketing plan with product name, recipe, how it will be packaged, package design, where it will be sold and suggested selling price.
11. Project manual
12. Any other project-related item

DIVISION 16E – Foodworks (Points 8,4,2)

CLASS NO.

1. Recipe with at least 40 recipes
2. Educational report on changes in nutritional needs from youth to adult to senior citizens
3. Plan a catered party from start to finish and outline every detail in a written and visual report
4. One double-crust fruit pie (include recipe)
5. One jar of pressure canned vegetables
6. One jar of pressure canned meat or combination product
7. One jar of jelly without added pectin (include recipe and complete instructions)
8. Beef jerky (include recipe)
9. Peanut butter from recipe in Project Manual
10. Project manual
11. Any other project-related item

DIVISION 16F – Up for the Challenge, Healthy Decisions (Points 4,2,1)

CLASS NO.

1. Chart of daily activity for one week
2. Chart of drink consumption for 2 days
3. Chart of Label Lingo

4. Charts of Whoa, Slow and Go Snack Foods
5. Chart of Steps
6. Chart of Screen Time
7. Project Manual
8. Any other project related exhibit

DIVISION 16G – Fast Foods (Points 4,2,1)

CLASS NO.

1. Notebook which could include project related activities
2. Educational display on a project related topic
3. Any project related display or poster
4. Any project related food item
5. Any other project-related item
6. Any other project-related item

DIVISION 16H – Teens Entertain (Points 6,3,1)

CLASS NO.

1. Any project related display or poster
2. Any project related food item
3. Any other project-related item
4. Any other project-related item

DIVISION 16I – Let’s Bake Bread (Points 6,3,1)

- This unit is designed for members who have completed several years of food-project work. One will learn the nutritional value, the function of each and interaction of ingredients.
- One will acquire the skills in selecting, preparing, serving and storing grain products.
- Use standard-loaf-size pans.
- Display bread on a large styrofoam meat tray.
- Must specify hand-made or bread machine.

CLASS NO.

1. ¾ loaf white-yeast bread on large meat tray
2. ¾ loaf 100% whole-wheat bread on large meat tray
3. ¾ loaf oatmeal bread on large meat tray
4. ¾ loaf rye bread on large meat tray
5. ¾ loaf sourdough bread
6. ¾ loaf multi-grain bread
7. One plate of shaped-sweet-dough-rolls (cloverleaf, butterhorns, fan tans, etc.) (4)
8. Variety rolls (4) (cinnamon, lemon, orange, pecan, etc.) on a small meat tray

DEPARTMENT JJ
DIVISION 17 – FORESTRY

DIVISION 17A – Follow the Path, Level 1
(Points 4,2,1)

CLASS NO.

1. Poster on a project related topic
2. Notebook which could include project related activities
3. Educational display on a project related topic
4. Project Manual
5. Any other project related exhibit
6. Any other project related exhibit

DIVISION 17B – Reach for the Canopy, Level 2
(Points 4,2,1)

CLASS NO.

1. Poster on a project related topic
2. Notebook which could include project related activities
3. Educational display on a project related topic
4. Project Manual
5. Any other project related exhibit
6. Any other project related exhibit

DIVISION 17C – Explore the Deep Woods,
Level 3 (Points 4,2,1)

CLASS NO.

1. Poster on a project related topic
2. Notebook which could include project related activities
3. Educational display on a project related topic
4. Project Manual
5. Any other project related exhibit
6. Any other project related exhibit

DEPARTMENT XX
DIVISION 18 – GOAT

DIVISION 18A – Getting Your Goat, Dairy Goat
Level 1 (Points 4,2,1)

CLASS NO.

1. Poster on project related topic
2. Notebook which could include project related activities
3. Educational display on a project related topic
4. A collection of feed ingredients and an explanation of their uses
5. Any other project related item

DIVISION 18B – Stepping Out, Dairy Goat
Level 2 (Points 4,2,1)

CLASS NO.

1. Poster on a project related topic
2. Notebook which could include project related activities
3. Educational display on a project related topic
4. An educational display kit of kidding supplies
5. Any other project related item

DIVISION 18C – Showing the Way, Dairy Goat
Level 3 (Points 4,2,1)

CLASS NO.

1. Poster on a project related topic
2. Notebook which could include project related activities
3. Educational display on a project related topic
4. Any other project related item

DIVISION 18D – Dairy Goat Products (Points
4,2,1)

CLASS NO.

1. 1 pint of whole milk
2. ½ cup of cream
3. ½ cup of raw butter
4. Minimum of 4 oz. of goat cheese

DIVISION 18E – Just Browsing, Meat Goat
Level 1 (Points 4,2,1)

CLASS NO.

1. Poster on a project related topic
2. Notebook which could include project related activities
3. Educational display on a project related topic
4. Project Manual
5. Any other project related exhibit
6. Any other project related exhibit

DIVISION 18F – Growing with Meat Goats,
Level 2 (Points 4,2,1)

CLASS NO.

1. Poster on a project related topic
2. Notebook which could include project related activities
3. Educational display on a project related topic
4. Project Manual
5. Any other project related exhibit
6. Any other project related exhibit

DIVISION 18G – Meating the Future, Meat Goat Level 3 (Points 4,2,1)

CLASS NO.

1. Poster on a project related topic
2. Notebook which could include project related activities
3. Educational display on a project related topic
4. Project Manual
5. Any other project related exhibit
6. Any other project related exhibit

DEPARTMENT NN

DIVISION 19 – HOME ENVIRONMENT
(Points 4,2,1)

- The judge will determine the most outstanding Home Environment Exhibit which will be eligible to advance to the Champion of Champion contest at the Eastern Montana Fair.
- Each category is open to any member enrolled in Home Environment

CLASS NO.

1. Design a room for someone in a wheelchair
2. Design a piece of furniture
3. Design a sound system
4. Renovate anything old
5. Make a photo display of old houses
6. Trace the history of an item in your home
7. Notebook of a remodel job or addition to your home you have done
8. Notebook on a room design including a floor plan
9. Notebook of comparing items for the home (eg. carpet, wallpaper, appliances, flooring, windows, or appliances)
10. Project completed in The Basic Touch, designing walls, windows and floors
11. Project completed in The Distinctive Touch, furniture, fabrics and storage
12. Project completed in The Finishing Touch, accessorizing your room
13. Project completed in The Environmental Touch
14. Any other project-related item



DEPARTMENT XX

DIVISION 20 – HORSELESS HORSE

DIVISION 20A – Giddy Up and Go (Points 4,2,1)

CLASS NO.

1. Poster on a project related topic
2. Notebook which could include project related activities
3. Educational display on a project related topic
4. A labeled collection of at least five different feed ingredients fed to horses
5. Any other project related item

DIVISION 20B – Head, Heart and Hooves
(Points 4,2,1)

CLASS NO.

1. Poster on a project related topic
2. Notebook which could include project related activities
3. Educational display on a project related topic
4. An emergency kit for both rider and horse
5. Any other project related item

DIVISION 20C – Stable Relationships (Points 4,2,1)

CLASS NO.

1. Poster on a project related topic
2. Notebook which could include project related activities
3. Educational display on a project related topic
4. Any other project-related item
5. Any other project-related item

DEPARTMENT KK

DIVISION 21 – HORTICULTURE/GARDENING

DIVISION 21A – Unit 1 – Budding Gardeners
(Points 4,2,1)

CLASS NO.

1. Poster on a project related topic
2. Notebook which could include project related activities
3. Educational display on a project related topic
4. A compost column and list of what to put in and what not to put in and why
5. A dish garden
6. Any other project related item

DIVISION 21B – Unit 2 – Branching Out (Points 4,2,1)

CLASS NO.

1. Poster on a project related topic
2. Notebook which could include project related activities
3. Educational display on a project related topic
4. A terrarium
5. Any other project related item

DIVISION 21C – Unit 3 – Digging Deeper (Points 4,2,1)

CLASS NO.

1. Poster on a project related topic
2. Notebook which could include project related activities
3. Educational display on a project related topic
4. A cold frame you have built
5. Any other project related item

DIVISION 21D – Horticulture Floral (Points 6,3,1)

- * Exhibits that do not contain the required number of flowers will not be considered for awards.
- * Exhibits will be judged for uniformity, maturity, variety, characteristics, freedom from disease, and quality
- * Collective displays will be judged on quality and artistic design
- * Displays are to be exhibited by the individual producer.
- * Floral display can be prepared by selecting any of the following according to the number of varieties that were grown by the member

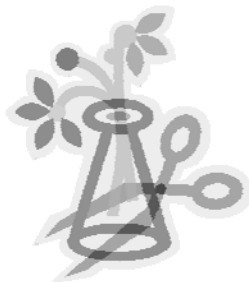

Bachelor Buttons, 3 stems
Bells of Ireland, 3 stems
Calendula, 3 stems
California Poppy, 3 stems
Carnations, 3 stems
Cosmos, 3 sprays
Dahlias, 3 small flowers
Dahlias, 1 large flower
Daisy, white, 3 stems
Daisy, colored, 3 stems
Gaillardia, 3 stems
Geranium, 3 stalks
Gladiolus, yellow, 1 spike
Gladiolus, pink, 1 spike
Gladiolus, red, 1 spike
Gladiolus, bicolor, 1 spike
Hollyhock, 1 stalk
Larkspur, 3 stems
Lilies, 1 stalk
Marigold, tall, orange, 3 stems
Marigold, tall, yellow, 3 stems
Marigold, dwarf, orange, 3 stems
Marigold, dwarf, yellow, 3 stems
Marigold, dwarf, bicolor, 3 stems
Nasturtium, 3 stems
Nicotiana, 3 stems
Pansy, 3 stems
Petunia, single, color A, 3 stems
Petunia, single, color B, 3 stems
Petunia, double, color A, 3 stems
Petunia, double, color B, 3 stems
Petunia, miniature, color A, 3 stems
Petunia, miniature, color B, 3 stems
Phlox, 1 stem
Pinks, 3 stems
Poppy, annual, 3 stems
Rose, Tea, 1 stem
Rose, Floribunda, 1 stem
Rose, Flat, 1 stem
Straw Flowers, 3 stems
Stocks, 3 stems
Snapdragons, Small, 3 stems
Snapdragons, Tall, 3 stems
Status, 3 stems
Sunflower, small blossom, 1 stem
Sunflower, medium blossom, 1 stem
Sunflower, large blossom, 1 stem
Sweet Pea, 3 stems
Yarrow, 3 stems
Zinnia, Pompom, 1 stem
Zinnia, Medium, 1 stem
Zinnia, Giant, 1 stem
Any other flower not listed

CLASS NO.

1. Twelve floral variety display
2. Nine floral variety display
3. Six floral variety display
4. Three floral variety display
5. Two floral variety display
6. One floral variety display
7. Container floral plant
8. Container foliage plant
9. Hanging floral plant
10. Hanging foliage plant
11. Decorative grass display
12. Coleus, plant or cut display

**DIVISION 21E – Horticulture –
Vegetable/Produce (Points 6,3,1)**

- * Exhibits that do not contain the required number of vegetables/produce will not be considered for awards.
- * Exhibits will be judged for uniformity, maturity, variety, characteristics, freedom from disease, and quality.
- * Displays are to be exhibited by the individual producer.

CLASS NO.

1. Beans, in pod (5)
2. Beets, table (3)
3. Berries, any variety (1/2 cup)
4. Broccoli (1 head or bunch)
5. Cabbage (1 head)
6. Carrots (3)
7. Cauliflower (1 head)
8. Corn, sweet, in husk (3)
9. Cucumbers (3)
10. Egg Plant (2)
11. Herbs, flavoring, 2 or more varieties in water
12. Kohlrabi (3)
13. Melon, any kind (1)
14. Onions (3)
15. Parsnips (3)
16. Peas (6 pods)
17. Peppers (3)
18. Potatoes (3)
19. Pumpkin (1)
20. Radishes (4, 1 Bunch)
21. Rhubarb (4 complete stalks, 1 bunch)
22. Rutabagas (3)
23. Spinach (3 plants with roots)

24. Squash (1)
25. Swiss Chard (3)
26. Tomatoes (3)
27. Turnips (3)
28. Other vegetable or fruit not included above
29. Funniest shaped vegetable
30. Biggest or heaviest vegetable
31. Longest vegetable
32. Garden Collection (Not less than 6 different vegetables or fruits)

DEPARTMENT NN

DIVISION 22 – LEADERSHIP (Points 4,2,1)

CLASS NO.

1. A notebook including your plan and reports of accomplishments with supporting materials for any of the activities carried out
2. A poster or display highlighting an area of your leadership
3. Any other project-related item

DEPARTMENT UU

DIVISION 23 – LEATHERCRAFT

Each exhibit winning the best of class in Leathercraft is eligible to advance to the Champion of Champions contest at the Eastern Montana Fair.

- Class 1 (coasters) is a mandatory pre-requisite to entering other lots in Units 1 – 3 of Leathercraft.

DIVISION 23A – Unit 1 (Points 4,2,1)

CLASS NO.

1. A minimum of 3 coasters depicting your stages of progress in Unit 1 Leathercraft
2. Any item using whip stitch lacing
3. Any item using running stitch lacing
4. Any project related item with lacing
5. Any project related item with tooling
6. Any project related item with stamping
7. Any other project related item



DIVISION 23B – Unit 2 (Points 6,3,1)

CLASS NO.

1. A minimum of 3 coasters depicting your stages of progress in Unit 2 Leathercraft
2. Any other item showing use of swivel knife
3. Any other item showing use of camouflage tool
4. Any other item showing use of beveling tool
5. Any other item using double loop lacing
6. Any other item showing decorative cuts
7. Any other project related item

DIVISION 23C – Unit 3 – (Points 8,4,2)

CLASS NO.

1. A minimum of 3 coasters depicting your stages of progress in Unit 3 Leathercraft
2. Any other item showing inverted carving techniques
3. Any other item showing beginning dyeing
4. Any other item showing lining
5. Any other item showing simple molding or shaping
6. Any other item showing hand-stitching
7. Any other project-related item

ADVANCED LEATHERCRAFT

DIVISION 23D – Units 4-10 (Points 10,5,3)

CLASS NO.

1. Advanced carving skills with or without beginning dyeing on item
2. Advance carving skills colored by solid-color dyeing, block dyeing, or shade dyeing on item
3. One framed or mounted, carved-leather picture (Item may be stained or colored)
4. One completed saddle, tooled or untooled
5. One article or matching set using creative stamping
6. One article or matching set using non-tooled or minimal tooling and non-sewn-leather-working techniques
7. One article made by sewing leather
8. Any other project-related item

DEPARTMENT NN

DIVISION 24 – NEEDLEWORK

Judge will determine most outstanding Crocheted Item, Knitted Item, Embroidery Item, and Cross Stitch Item. Each of these items will be eligible to advance to the Champion of Champions at the Eastern Montana Fair.

DIVISION 24A – Knitting (Points 6,3,1)

CLASS NO.

1. Two-needle knitted item
2. Two-needle knitted item
3. 2 colors worked into knitted item
4. Sweater with raglan sleeves
5. Item using cable stitch
6. Item using moss or seed stitch
7. Item with buttonholes
8. Coat sweater with design
9. Article using circular needles
10. Four needle knitted item
11. Afghan
12. Poster, display, or notebook of at least 3 examples of project progression
13. Any other project-related item

DIVISION 24B – Crochet (Points 6,3,1)

Beginner: First & Second year crochet members

CLASS NO.

1. Item using one type of stitch
2. Item using a combination of stitches
3. Item made with thread
4. Item made with yarn
5. Item made with wool
6. Poster with 3 examples of project progression (1st, 2nd, 3rd examples of progression in the project)
7. Poster with examples of stitches: single, double and triple
8. Any project related item

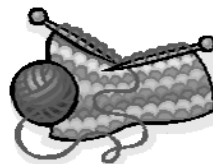

DIVISION 24C – Advanced Crocheting (Points 8,4,2)

Advanced: Three plus years in crochet project

CLASS NO.

1. Afghan
2. Doily or centerpiece
3. Item made with yarn
4. Item made with thread
5. Item made with wool
6. Notebook on example of crocheting with different mediums
7. Any other project related item
8. Any other project related item

DIVISION 24D – Embroidery (Points 6,3,1)

All wall hanging must be mounted properly and backed.

CLASS NO.

1. Article using one or more different embroidery stitches
2. Article using two or more different embroidery stitches
3. Article using three or more different embroidery stitches
4. Article using four or more different embroidery stitches
5. Article using five or more different embroidery stitches
6. Article using six or more different embroidery stitches
7. Article using smocking
8. Article using cross stitch
9. Any other project-related item
10. Any other project-related item

DEPARTMENT UU

DIVISION 25 – OUTDOOR ADVENTURE

DIVISION 25A – Hiking Trails (Points 4,2,1)

CLASS NO.

1. Examples of items to pack in a backpack for a day hike. (Can be just pictures)
2. Exhibit showing comparison of quality hiking or camping equipment
3. Exhibit on hiking safety
4. Exhibit explaining GPS use for hiking and geocaching
5. Journal and photos of a hike and/or camping trip you completed
6. Any other project related item

DIVISION 25B – Camping Adventures (Points 6,3,1)

CLASS NO.

1. Examples of items to pack in a backpack for an overnight hike (can be just pictures)
2. Exhibit showing comparison of quality camping equipment
3. Exhibit on camping safety
4. Eight or more recipes used while camping
5. Exhibit showing knot tying and/or tool use
6. Exhibit showing how to choose a camp site and/or appropriate camp shelters
7. Journal and photos of a camping/hiking trip you completed
8. Any other project related item

DIVISION 25C – Backpacking Expeditions (Points 8,4,2)

CLASS NO.

1. Exhibit of items needed for an extended backpacking trip (can be pictures)
2. Exhibit on outdoor survival skills and/or first aid
3. Ten or more recipes used while backpacking and camping
4. Exhibit showing how to use maps and/or compass or GPS
5. Exhibit showing Leave No Trace Principles
6. Exhibit showing how to purify water
7. Journal and photos of a backpacking and/or camping trip you completed
8. Any other project related item

DEPARTMENT TT

DIVISION 26 – PHOTOGRAPHY

Hints for preparing fair entries for the photography project:

- Keep the mount or poster board absolutely clean.
- Titles should be as neat as possible. Do your titling on lightly-ruled lines which can be erased later.
- Even-spacing around prints on the mount is very important.
- Do a good job mounting the pictures using rubber cement. Be sure to coat both surfaces and allow time for the cement extending beyond the edges of the pictures to dry, then it will rub off.

- Be sure the poster board you use for mounting is heavy enough.
- All photography exhibits should include a written explanation of your picture exhibit and what you learned.
- Each class should be mounted separately. Each exhibit winning Best of Class in Units 1,2 & 3 and Photography trophy winners are eligible to advance to the Champion of Champions Contest at the Eastern Montana Fair.
- Pictures may be taken with a 110 camera, a 35 millimeter camera, an advanced photo system, a single use camera, and/or a digital camera.

DIVISION 26A – Unit 1 – Focus on Photography (Points 4,2,1)

CLASS NO.

1. Poster with 8 or more parts of camera labeled
2. Outdoor pictures at different times of day. Use the same scene. (3 pictures or more)
3. Photos of shadows (3)
4. Lightning (front, back, side and top lightning) Label each type of lightning. (4 photos)
5. Using Flash (3 ft., 5 ft., 12 ft.) (3)
6. Fill Flash (2)
7. Composition: horizontal picture with labeled foreground, middle-ground and background
8. Photos at different distances. Closeups, medium and long shots. (at least one of each)
9. Trick pictures (3)
10. Black and White Photos (3)
11. Scrapbook pages of pictures you took
12. Photo Story (3 to 10 pictures)
13. Any other project related item

DIVISION 26B – Unit 2 – Controlling the Image (Points 4,2,1)

CLASS NO.

1. Short and long Depth of Field (at least 1 of each)
2. Low light (3)
3. Hard and Soft light (at least 1 of each)
4. Silhouettes (2 or more)
5. Using Flash (2 or more)
6. Rule of thirds (2 or more)

7. Golden Triangle and Golden Rectangle (at least one of each)
8. Different viewpoints (3 or more)
9. Photo Story (3 to 10 pictures)
10. Use shutter speeds to show action (3 or more)
11. Show bits and pieces of subject (3)
12. Scrapbook page of pictures you took
13. Any other project related item

DIVISION 26C – Unit 3 – Mastering Photography (Points 6,3,1)

CLASS NO.

1. Lenses – 3 pictures of same scene using normal, wide angle and telephoto lens
2. Special effects using filters (3 or more)
3. Exposure: (one overexposed, one underexposed, one balanced exposure)
4. Photos without flash using natural or artificial light (3 or more)
5. Reflections as subjects (2 or more)
6. Composition: framing the subject, lines that lead the eye (1 or more of each)
7. Still life (3)
8. Portraits (2 or more)
9. Use color as a composition tool (3 or more)
10. Photos showing texture, patterns, or shapes (3 or more)
11. Photos showing interesting details (3)
12. Photos that could be used in a brochure (3 or more)
13. Any other project related item

DIVISION 26D – Videography (Points 8,4,2)

CLASS NO.

1. Short – 1-2 minute film
2. Long – 5 minute film
3. Public Service Announcement (PSA)
4. Storyboard and/or script for film production
5. Podcast of Video created
6. Research on topic for film creation
7. Filmed Interviews on specific topic



**DIVISION 26E – Odds and Ends (Photography)
(Points 8,4,2)**

- This division is open to all 4-H members entered in any level of photography (Camera Type not relevant)
- If computer enhanced, attach original photo

CLASS NO.

1. Action
2. Agricultural
3. Animal or animals
4. Baby or babies
5. Character Study
6. Christmas Card Scene
7. Clouds
8. Collage or Layered
9. Fallon County Views (3)
10. Farm Scene
11. Flowers
12. Interior
13. Outdoor Architecture – New
14. Outdoor Architecture – Old
15. Picture Story (3)
16. Portrait Animal
17. Portrait Child
18. Portrait Adult
19. Ranch Scene
20. Sunrises
21. Sunsets
22. Any Other Identify
23. Child or children
24. Humorous
25. Landscape
26. Night
27. Patriotic
28. Person or persons
29. Rainbow
30. Seasons (Picture of same subject/different seasons) 3-4 pictures
31. Wild animals, natural habitat
32. Photo Calendar (Using photos you have taken)

DEPARTMENT JJ

DIVISION 27 – POCKET PETS

DIVISION 27A – Level I – Pet Pals (Points 4,2,1)

CLASS NO.

1. Poster on a project related topic
2. Notebook which could include project related activities
3. Educational display on a project related topic
4. Any other project related item

**DIVISION 27B – Level II – Scurrying Ahead
(Points 4,2,1)**

CLASS NO.

1. Poster on a project related topic
2. Notebook which could include project related activities
3. Educational display on a project related topic
4. Any other project related item

**DIVISION 27C – Level III – Scaling the Heights
(Points 4,2,1)**

CLASS NO.

1. Poster on a project related topic
2. Notebook which could include project related activities
3. Educational display on a project related topic
4. Any other project related item

**DIVISION 27D – All Levels of Pocket Pets
(Points 6,3,1)**

Open to all youth enrolled in the Pocket Pets Project

CLASS NO.

1. Your live pocket pet
2. Your live pocket pet

DEPARTMENT XX

DIVISION 28 – POULTRY

DIVISION 28A – Level 1 – Scratching the Surface (Points 4,2,1)

CLASS NO.

1. Poster on a project related topic
2. Notebook which could include project related activities
3. Educational display on a project related topic
4. A homemade poultry crate
5. Any other project related item

**DIVISION 28B – Level 2 – Testing Your Wings
(Points 4,2,1)**

CLASS NO.

1. Poster on project related topic
2. Notebook which could include project related activities
3. Educational display on a project related topic
4. A homemade candler with a description of how it works
5. Any other project related item

**DIVISION 28C – Level 3 – Flocking Together
(Points 4,2,1)**

CLASS NO.

1. Poster on a project related topic
2. Notebook which could include project related activities
3. Educational display on a project related topic
4. A collection of eggs dyed with natural dyes (label each egg with the dye material(s) used)
5. Any other project related item

DIVISION 28D – Poultry By-Products (Points 4,2,1)

CLASS NO.

1. 6 eggs (recommended they be all gathered from the same project animal)
2. Any other project related item

DEPARTMENT NN

DIVISION 29 – QUILTING, PATCHWORK, APPLIQUE (Points 6,3,1)

Judge will determine most outstanding Quilt, Patchwork, Appliqué item. This item will be eligible to advance to the Champion of Champions at the Eastern Montana Fair.

- Any size quilt, wall hanging or garment will be accepted.
- All work must be completed by the 4-H member. Professionally machine quilted items will not be accepted.

CLASS NO.

1. Article or garment – using appliqué
2. Quilt – using appliqué
3. Wall Hanging – using appliqué
4. Any other project related item – using appliqué
5. Article or garment – using patchwork – quilted or tied
6. Quilt – using patchwork – quilted or tied (Pattern)
7. Quilt – using patchwork – quilted or tied (No Pattern)
8. Wall Hanging – using patchwork – quilted or tied – (Pattern)
9. Wall Hanging – using patchwork – quilted or tied – (No Pattern)
10. Any other project related item – using patchwork – quilted or tied
11. Article or garment – hand or machine quilted

12. Quilt – hand or machine quilted
13. Wall hanging – hand or machine quilted
14. Any other project related item – hand or machine quilted
15. Set of quilted placemats
16. A table runner
17. Quilt, strip piecing with no backing fabric
18. Article or garment, strip piecing with no backing fabric
19. Quilt, strip piecing using a backing fabric
20. Article or garment, strip piecing using a backing fabric
21. Rag quilt

DEPARTMENT XX

DIVISION 30 - RABBIT

DIVISION 30A – Level 1 – Hop to IT! And What's Hoppening (Points 4,2,1)

CLASS NO.

1. Poster on a project related topic
2. Notebook which could include project related activities
3. Education display on a project related topic
4. A homemade rabbit cage
5. A homemade rabbit nest box
6. Any other project related item

DIVISION 30B – Level 2 – A Jump Ahead (Points 4,2,1)

CLASS NO.

1. Poster on a project related topic
2. Notebook which could include project related activities
3. Educational display on a project related topic
4. A mobile carrying case for a rabbit you have designed and built
5. Any other project related item

DIVISION 30C – Level 3 – Leaps and Bounds (Points 4,2,1)

CLASS NO.

1. Poster on a project related topic
2. Notebook which could include project related activities
3. Educational display on a project related topic
4. A collection of ten recipes using rabbit meat
5. Any other project related item

DEPARTMENT JJ

DIVISION 31 – RANGE MANAGEMENT

The Grand Champion Range exhibit and Best of Class Beginning Range are eligible to advance to the Champion of Champions Contest at the Eastern Montana Fair.

DIVISION 31A – Beginning Range (Points 4,2,1)

CLASS NO.

1. Educational poster or display
2. Plant notebook showing, through illustrations or actual specimens, the parts of range plants
3. Beginning Range completed manual
4. Any other project-related item

DIVISION 31B – Unit I (Points 4,2,1)

CLASS NO.

1. Completed project manual
2. Plant collection – five plants identified
3. Any other project-related item

DIVISION 31C – Unit II (Points 6,3,1)

CLASS NO.

1. Completed project manual
2. Plant collection – 11 plants
3. Plant Press
4. Any other project-related item

DIVISION 31D – Unit III (Points 6,3,1)

CLASS NO.

1. Completed project manual
2. Plant collection – 28 plants – includes 11 from Unit II
3. Educational display or poster
4. Any other project-related item

DIVISION 31E – Unit IV (Points 8,4,2)

CLASS NO.

1. Completed project manual
2. Educational display or poster
3. One year range-plan for a ranch
4. Any other project-related item

DIVISION 31F – Unit V (Points 8,4,2)

CLASS NO.

1. Youth range manual, project outline, and project report
2. Display or poster relating to project
3. Any other project-related item

DEPARTMENT UU

DIVISION 32 - ROBOTICS

DIVISION 32A – Robotics, Level 1, Explorer (Points 4,2,1)

CLASS NO.

1. Poster on a project-related topic
2. Notebook that may contain completed project activities
3. Educational display on a project-related topic
4. Any other project-related item

DIVISION 32B – Robotics, Level 2, Probe (Points 6,3,1)

CLASS NO.

1. Poster on a project-related topic
2. Notebook that may contain completed project activities
3. Educational display on a project-related topic
4. Any other project-related item

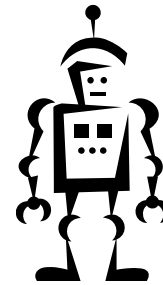

DEPARTMENT WW

DIVISION 33 – SCRAPBOOK

Any member or club can enter lots in Scrapbook class. Rosettes are awarded to the best exhibit by a Junior Exhibitor and Senior Exhibitor. State age on entry tag. No trophy awarded in this area.

DIVISION 33A – Scrapbook (Points 4,2,1)

CLASS NO.

1. Member's journal
2. 4-H Club scrapbook
3. Member's 4-H scrapbook

DEPARTMENT WW

DIVISION 34 – SELF-DETERMINED (Points 8,4,2)

This project is designed for members to create a project that is not currently recognized by the 4-H program. The Self-Determined project work should not be able to be achieved by taking any of the projects available to 4-H members at this time.

DIVISION 34A – Non-livestock Project

CLASS NO.

1. Poster on a project related topic
2. Project related notebook or scrapbook
3. Educational display
4. Essay
5. Display of 3 project items (items should complement each other)
6. Any homemade item used in project (not a result of)
7. Any other project-related item

DIVISION 34B – Livestock project (Points 4,2,1)

CLASS NO.

1. Display of project item/animal
2. Poster, notebook, or educational display
3. Any other project related item

DEPARTMENT XX

DIVISION 35 – SHEEP

DIVISION 35A – Sheep 1 – Lambs, Rams And You (Points 4,2,1)

CLASS NO.

1. Poster on a project related topic
2. Educational display on a project related topic
3. Notebook which could include project related activities
4. Poster with your drawing of a sheep with at least 25 body parts labeled
5. A poster of at least ten sheep by-products, where they are found and their use
6. A lambing supply kit (neat and labeled) you have put together
7. Any other project related item

DIVISION 35B – Sheep 2 – Shear Delight (Points 4,2,1)

CLASS NO.

1. Poster on a project related topic
2. Educational display on a project related topic
3. Notebook which could include project related activities

4. Using an actual feed tag, identify the feed ingredients and the nutrients they supply
5. Collection of at least three wool samples with explanation
6. Any other project-related item

DIVISION 35C – Sheep 3 – Leading The Flock (Points 4,2,1)

CLASS NO.

1. Poster on a project related topic
2. Educational display on a project related topic
3. Notebook which could include project related activities
4. Drawing of lamb with all the retail cuts labeled.
5. Any other project-related item

DEPARTMENT UU

DIVISION 36 – SHOOTING SPORTS

The judge will determine the most outstanding Shooting Sports Exhibit which will be eligible to advance to the Champion of Champions contest at the Eastern Montana Fair.

DIVISION 36A – Rifles (Points 4,2,1)

CLASS NO.

1. Poster on a project related topic
2. Educational display on a project related topic
3. Notebook which could include project related activities
4. Scored targets in a notebook
5. Any other project-related item

DIVISION 36B – Archery (Points 4,2,1)

CLASS NO.

1. Poster on a project related topic
2. Educational display on a project related topic
3. Notebook which could include project related activities
4. Any other project-related item

DIVISION 36C – Hunting (Points 4,2,1)

CLASS NO.

1. Poster on a project related topic
2. Educational display on a project related topic
3. Notebook which could include project related activities
4. Any project-related item

DIVISION 36D – Shotgun (Points 4,2,1)

CLASS NO.

1. Poster on a project related subject
2. Educational display on a project related topic
3. Notebook which could include project related activities
4. Any other project-related item

DIVISION 36E – Pistol (Points 4,2,1)

CLASS NO.

1. Poster on a project related topic
2. Educational display on a project related topic
3. Notebook which could include project related activities
4. Scored targets in a notebook
5. Any other project-related item

DIVISION 36F – 22 Rim-Fire Rifle (Points 4,2,1)

CLASS NO.

1. Poster on a project related subject
2. Educational display on a project related topic
3. Notebook which could include project related activities
4. Any other project-related item

DIVISION 36G – Muzzleloading (Points 4,2,1)

CLASS NO.

1. Poster on a project related subject
2. Educational display on a project related topic
3. Notebook which could include project related activities
4. Any other project-related item

DIVISION 36H – Cowboy Action (Points 4,2,1)

CLASS NO.

1. Poster on a project related subject
2. Educational display on a project related topic
3. Notebook which could include project related activities
4. Any other project-related item

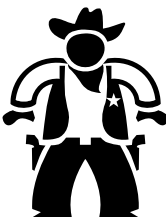

DEPARTMENT WW

DIVISION 37 SHORT TERM

- Short-Term project consists of any type arts or crafts that won't fulfill requirement in any other 4-H Project – county or state.
- Member must enroll in Short-term project to exhibit in this class at the fair.
- Members may exhibit no more than two entries of the same type of art or craft.
- A project information sheet must be attached to each entry.

DIVISION 37A – Short term (Points 4,2,1)

CLASS NO.

1. Art or craft item
2. Art or craft item
3. Art or craft item
4. Art or craft item
5. Any other project-related item

DEPARTMENT UU

DIVISION 38 – SMALL ENGINES

DIVISION 38A – Unit 1 – Crank It Up! (Points 4,2,1)

CLASS NO.

1. Poster on a project related topic
2. Notebook which could include project related activities
3. Educational display on a project related topic
4. Any other project related item

DIVISION 38B – Unit 2 – Warm It Up! (Points 6,3,1)

CLASS NO.

1. Poster on a project related topic
2. Notebook which could include project related activities
3. Educational display on a project related topic
4. Any other project related item

DIVISION 38C – Tune It Up! (Points 8,4,2)

CLASS NO.

1. Poster on a project related topic
2. Notebook which could include project related activities
3. Educational display on a project related topic
4. Any other project related item

DEPARTMENT UU
DIVISION 39 – SPORTFISHING

DIVISION 39A – Take the Bait (Points 4,2,1)

CLASS NO.

1. Poster on a project related topic
2. Notebook that may contain completed project activities
3. Educational display on a project related topic
4. Your tackle box and an inventory list of contents
5. Any other project related item

DIVISION 39B – Reel in the Fun (Points 6,3,1)

CLASS NO.

1. Poster on a project related topic
2. Notebook that may contain completed project activities
3. Educational display on a project related topic
4. A fly wallet constructed by member containing at least one artificial fly made by member
5. Any other project related item

DIVISION 39C – Cast Into the Future (Points 8,4,2)

CLASS NO.

1. Poster on a project related topic
2. Notebook that may contain completed project activities
3. Educational display on a project related topic
4. A collection of artificial lures and/or flies made by member.
5. Any other project related item

DEPARTMENT XX
DIVISION 40 - SWINE

DIVISION 40A – Level 1 – Growing with Swine and Squeal Appeal (Points 4,2,1)

CLASS NO.

1. Poster on a project related topic
2. Educational display on a project related topic
3. Notebook which could include project related activities
4. A poster or educational display of at least 10 pork-by-products
5. Poster with hand drawing of a pig with at least 20 parts labeled

6. Poster or display that identifies the ingredients of at least 5 swine feed samples
7. Any other project-related item

DIVISION 40B – Level 2 – Hamming It Up (Points 4,2,1)

CLASS NO.

1. Poster on a project related topic
2. Educational display on a project related topic
3. Notebook which could include project related activities
4. Poster or notebook of at least 10 pork cuts (include name, location, and preferred types of cooking)
5. Any other project-related item

DIVISION 40C – Level 3 – Going Whole Hog (Points 4,2,1)

CLASS NO.

1. Poster on a project related topic
2. Educational display on a project related topic
3. Notebook which could include project related activities
4. Poster or notebook of at least ten swine diseases, their symptoms and how each can be treated
5. Any other project-related item

DEPARTMENT WW
DIVISION 41 – THEATER ARTS

DIVISION 41A – Play the Role (Points 4,2,1)

CLASS NO.

1. Display of tongue twisters you made up
2. Scene you have written with directions indicating voice tone
3. Script you have written with flashback scenes
4. Photos of the clown character you created
5. Picture story you created for a script
6. Series of stage pictures for a story
7. Critic's review of a musical you reviewed
8. Any other exhibit related to project
9. Any other exhibit related to project



DIVISION 41B – Become a Puppeteer (Points 4,2,1)

CLASS NO.

1. Sock puppet you made
2. Rod puppet you made
3. Everyday found object puppet
4. Puppet character you built
5. Puppet stage you built
6. Any other exhibit related to project
7. Any other exhibit related to project

DIVISION 41C – Set the Stage (Points 6,3,1)

CLASS NO.

1. Costume you designed
2. Set you designed and built
3. Color wheel you designed
4. Play prompt book you created
5. Any other exhibit related to project
6. Any other exhibit related to project

DEPARTMENT XX

DIVISION 42 – VETERINARY SCIENCE

- Exhibitor will prepare exhibits from the unit enrolled in
- Drawings can be observed in each unit book
- Drawings can be colored, if desired
- The judge will determine the most outstanding Veterinary Science Exhibit which will be eligible to advance to the Champion of Champions contest at the Eastern Montana Fair

DIVISION 42A – Veterinary Science Unit 1 (Points 4,2,1)

CLASS NO.

1. Educational display or poster on related topic
2. Notebook of project activities completed for Unit 1
3. Freehand anatomical drawing of a part of an animal with labeled parts
4. Any other project-related item

DIVISION 42B – Veterinary Science Unit 2 (Points 6,3,1)

CLASS NO.

1. Educational display or poster on related topic
2. Notebook of project activities completed for Unit 2

3. Collect, mount and label 3 poisonous plants
4. Freehand drawing or poster of subject in Unit 2D
5. Any other project-related item

DIVISION 42C – Veterinary Science Unit 3 (Points 8,4,2)

CLASS NO.

1. Notebook or self-study activity
2. Display or poster relating to project
3. Any other project-related item

DEPARTMENT JJ

DIVISION 43 – WEED SCIENCE

The Grand Champion Weed exhibit is eligible to advance to the Champion of Champions Contest at the Eastern Montana Fair.

DIVISION 43A – Unit 1 Weed Science (Points 4,2,1)

CLASS NO.

1. Poster on a project related topic
2. Notebook that may contain completed project activities
3. Educational display on a project related topic
4. Plant press constructed by exhibitor
5. Collection of 12 weeds 1st year and 25 weeds for 2nd year - Properly mounted and identified
6. Any other project-related item

DIVISION 43B – Unit II Weed Science (Points 6,3,1)

CLASS NO.

1. Poster on a project related topic
2. Notebook that may contain completed project activities
3. Educational display on a project related topic
4. Collection of 32 weeds, including 25 from Unit 1
5. Any other project-related item



DIVISION 43C – Unit III Weed Science (Points 6,3,1)

CLASS NO.

1. Poster on a project related topic
2. Notebook that may contain completed project activities
3. Educational display on a project related topic
4. Collection of 40 weeds, including 32 weeds from Unit 2. Must include three weeds on the Montana State Noxious Weed list.
5. Any other project-related item

DIVISION 43D – Unit IV Weed Science (Points 8, 4,2)

CLASS NO.

1. Collection of eight weeds known to be poisonous to livestock (Properly mounted and identified)
2. Notebook or display on weed options you have chosen
3. Project manual
4. Any other project-related item (Identify)

DEPARTMENT UU

DIVISION 44 – WILDLIFE CONSERVATION

- The judge will determine the most outstanding Wildlife Exhibit which will be eligible to advance to the Champion of Champions Contest at the Eastern Montana Fair

DIVISION 44A – Level 1, The Worth of Wild Roots (Points 6,3,1)

CLASS NO.

1. Poster on a project related topic
2. Notebook which could include project related activities
3. Education display on a project related topic
4. Nature Journal (pg. 13-14)
5. Make a diorama of a wildlife scene, wildlife tracks, or wildlife signs
6. Write a Wildlife Essay
7. Wildlife Experiments (pgs. 44-60)
8. Any Display Board or poster exhibit (pg. 39)
9. Any other project related exhibit

DIVISION 44B – Level 2, Living Wild in an Ecosystem (Points 6,3,1)

CLASS NO.

1. Poster on a project related topic
2. Notebook which could include project related activities
3. Educational display on a project related topic
4. Project Manual
5. Your Nature Journal
6. A house you made for wildlife
7. Your wildlife habitat plan
8. A birdbath or feeder you made
9. Your integrated pest management plan
10. Any display related to project

DIVISION 44C – Level 3, Managing in a world with You and Me (Points 6,3,1)

CLASS NO.

1. Poster on a project related topic
2. Notebook which could include project related activities
3. Educational display on a project related topic
4. Project Manual
5. Any other project related exhibit
6. Any other project related exhibit

DEPARTMENT UU

DIVISION 45 – WOODWORKING

Each exhibit winning Best of Class in Skill Level 1, 2, 3, and 4 is eligible to advance to the Champion of Champions contest at the Eastern Montana Fair.

DIVISION 45A – Level 1 – Measuring Up (Points 4,2,1)

CLASS NO.

1. Notebook that may contain completed project activities
2. Tool identification and usage notebook (at least 10 hand tools)
3. Safety poster
4. Display of different types of wood
5. Poster teaching differences between hard and soft woods
6. Display of at least 10 different type of nails and screws
7. Display or poster identifying different types and grades of sandpaper
8. Exhibit or article from project manual plans
9. Any other project-related item
10. Any other project-related item

**DIVISION 45B – Level 2 – Making The Cut
(Points 6,3,1)**

CLASS NO.

1. Notebook that may contain completed project activities
2. Tool identification and usage notebook (at least 10 hand tools and 5 power tools)
3. Poster showing the different types of fiberboard and plywood
4. Educational poster or notebook on liquid finishers (paint, shellac, varnish, etc.)
5. An item made using project manual plans
6. Any other project-related item
7. Any other project-related item

**DIVISION 45C – Level 3 – Nailing it Together
(Points 8,4,2)**

CLASS NO.

1. Any other project-related item Poster on a project related topic
2. Notebook that may contain completed project activities
3. Educational display of four different types of joints
4. Educational display or notebook on different types of hinges, hasps, and flush plates
5. Any item made using project manual plans
6. Any other project-related item
7. Any other project-related item

DIVISION 45D – Level 4 – Finishing Up (Points 10,5,3)

CLASS NO.

1. Notebook that may contain completed project activities
2. A set of woodworking plans you have designed and made yourself
3. Notebook or poster identifying the names, uses and characteristics of various adhesives
4. A wood project that you have refinished
5. Any item made using project manual plans
6. Any other project-related item
7. Any other project-related item

DEPARTMENT WW

DIVISION 46 – WRITING ARTS

To exhibit in this category, you must be currently enrolled in 4-H Cowboy Poetry project. There is only one level in this project and it is self-paced. Project books and records are not to be exhibited or judged.

DIVISION 46A – Cowboy Poetry (Points 8,4,2)

CLASS NO.

1. A poster showing what you have learned about cowboy poetry.
2. Display of at least 3 original poems written by you during the current year.
3. An educational display related to what you have learned about rhyme schemes or meter.
4. An educational display about some of the classic cowboy poets.
5. An educational display about Western culture or history, especially about your local area.
6. Display of examples of cowboy poetry you have found in your local library.
7. A photo story of your participation in a cowboy poetry gathering.
8. A photo story showing you teaching others to write and recite their own original poetry.
9. Any educational display related to what you have learned in this project.

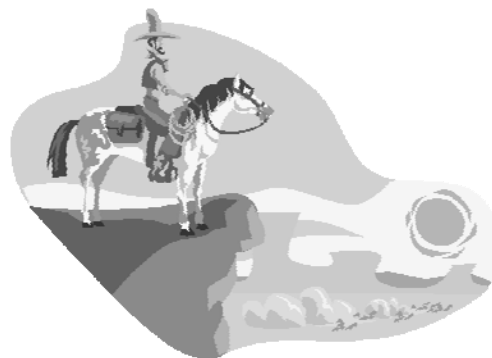

SPECIAL 4-H INDOOR AWARDS

Given to member with most Grand Champions in each area. If there should be a tie, then award goes to member with most blue ribbons in the area of the tie. Awards will be useful items and change from year to year.

Areas receiving awards:

Communications, Arts and Leisure - Photography, Leathercraft, Cowboy Poetry and Exploring 4-H

Family and Consumer Science - Child Development, Sewing, Family Life, Foods & Nutrition, and Home Environment

Indoor Animal Science - all indoor animal project exhibits

Mechanical Science - Aerospace, Bicycle, Electricity, Robotics, Small Engines and Woodworking

Natural Science – Entomology, Fishing, Forestry, Outdoor Adventures, Range Management, Shooting Sports and Wildlife

Plant Science - Crop, Weed and Horticulture

Keith and Sharon Schwartz will award \$25.00 to the 4-H member receiving the most blue ribbons on indoor exhibits and \$15.00 to the 4-H member receiving the second most blue ribbons on indoor exhibits.

The Willard Homemakers will award a cookbook to the exhibitor for the most 4-H Food Exhibits entered in the Fallon County Fair.

Individual 4-H Member with the most outstanding 4-H Centennial Display will receive a special award.

4-H Club with the most outstanding 4-H Centennial Display will receive a special award.

** More awards may become available after the printing of this fairbook.

FALLON COUNTY 4-H & FFA LIVESTOCK RULES

1. Market Livestock ownership deadlines are:
Market Steers: February 1st
Market Sheep/Swine/Goats: June 1st
Market Poultry/Rabbits: July 1st
2. For the purpose of these rules; a 4-H project and an FFA SAE will be referred to as “project”.
3. If you are a member who is in both 4-H and FFA, you must choose at the time of the possession date which organization you wish to sell your animal under. Family alternate animals do not need to be designated 4-H or FFA. The member is only allowed to sell one market beef, one market swine, one market lamb, one market goat, one meat-type chicken and one rabbit.
4. To exhibit a market animal, the member must be enrolled in the appropriate market project. To exhibit a breeding animal, the member must be enrolled in the appropriate breeding project. The same animal, however, cannot be entered in both the market and breeding class at the fair.
5. The market animal classes are open to only Fallon County 4-H and FFA members.
6. The breeding animal classes are open to Fallon County and Carter County 4-H and FFA members.
7. 4-H and FFA livestock will be judged together.
8. Livestock Quality Assurance will be held at least twice a year to be attended by first year 4-H livestock projects members and again as a senior 4-H livestock member. 4-H and FFA members who wish to participate in Steer of Merit, must take the MQA program every other year.
9. All Market Animals must be weighed in. Weigh-in times will be Thursday evening to 9:00 p.m. A “bill of sale” must be turned in for market beef.
10. All stall and pens should be cleaned before 7:45 a.m. each day.
11. Judging will begin promptly at 8:00 a.m. on Wednesday, 9:00 a.m. on Thursday and 8:00 a.m. on Friday.
12. Only 4-H and FFA members will be permitted to care for, fit, show and sell their animals on exhibit unless good reason is presented to the Livestock Committee for the necessity of other arrangements. Leaders, family members and other current 4-H/FFA members may assist in fitting of exhibit animals.
13. Montana 4-H and FFA require that animals be handled in a proper and ethical manner in accordance with accepted modern-animal husbandry and scientific practices. In addition, adequate care, including watering, feeding and comfort should be appropriately provided to all animals. Any individual treating an animal in any other manner may be asked to leave the grounds.
14. Exhibitors, their parents, leaders and instructors have a serious responsibility to follow animal-health practices approved by the industry and the U.S. Department of Agriculture to assure that meat customers are receiving wholesome food. Health aids and other approved products should be used with care, according to prescribed practices, only when needed, and in correct amounts.
15. Montana 4-H and FFA require that market animals meet all the Food and Drug Administration regulations governing management and safety practices. Approved withdrawal times from health aids and growth stimulants must be followed. Animals that have not met these standards will not be allowed to be sold.
16. No 4-H or FFA Livestock animal is to be administered a tranquilizer in any form to show at the Fallon Co. Fair.
17. The following dress code will be followed for each 4-H livestock project except horse. A long sleeved white or solid colored shirt & dark brown, black or blue jeans, boots & western hat (or bareheaded); no caps allowed. The wearing of a tie or organizational scarf is preferred. White clothing is suggested for contestants in dairy projects. No tennis shoes or sandals will be allowed. Horse projects require a different dress code. FFA members

- must follow official FFA dress code. If dress code is not followed the contestant will be dropped a ribbon placing.
18. All 4-H and FFA members should be present 30 minutes prior to the livestock judging and the livestock sale.
 19. 4-H and FFA members should have their animals under control at all times at the fair. If this cannot be achieved, the Barn Superintendent has the authority to make other arrangements for the animal.
 20. Neck ropes are mandatory for all cattle not in an enclosed pen at the Fallon County Fair.
 21. Swine will be shown with a riding crop/bat/cane or pole only.
 22. All cattle must be halter broke by fair time & all members in these projects should know how to tie a bowline knot, in case of emergency so your animal can be released quickly.
 23. 4-H and FFA members must sell their livestock at the regular sale if they desire to offer them for sale at the fair.
 24. A base price will be set on market steers, sheep, goats and swine. Should a buyer choose to pay only what they have bid over the base price, the person/livestock yard setting the base price owns the animal.
 25. All market steers will be entered in one lot number. Grand Champion and Reserve Champion will advance to the Eastern Montana Fair in Miles City.
 26. The 4-H and FFA livestock will be sold in the following order:
 FIRST - Blue ribbon steers
 SECOND - Red ribbon steers
 THIRD - Blue ribbon hogs
 FOURTH - Red ribbon hogs
 FIFTH - Blue Ribbon lambs
 SIXTH - Red Ribbon lambs
 SEVENTH - Blue Ribbon goats
 EIGHTH - Red Ribbon goats
 NINTH - Blue Ribbon Poultry
 TENTH - Red Ribbon Poultry
 ELEVENTH - Blue Ribbon Rabbits
 TWELTH - Red Ribbon Rabbits

***Resale animals will be sold at the end of the Sale.**

***The Judge will determine sale order.**

27. Livestock sale advertisement, picture expenses, check-off expenses, ear tags etc... for market livestock will be taken out of the 4-H and FFA member's check before they receive it. This amount will be 2.0% of the gross amount the market animal(s) sold for.
28. The 4-H and FFA livestock sale will take place at approximately 4:30 p.m. immediately following the Saturday afternoon rodeo performance. The sale is held in the livestock pavilion. Signs will be posted in the building giving purchaser's name, sale price and approximate weight. Exhibitors will be solely responsible for the care and ownership of such livestock until they are dismissed to the owners at the close of the fair.
29. The superintendents have the authority to remove from the fairgrounds anyone publicly expressing disapproval of the judge's decision. Judge's decisions are final.
30. Persons with concerns about livestock projects should contact the Livestock Superintendents and then the Livestock Grievance Committee. The Livestock Grievance Committee may make decisions at the Fair in cases of unforeseen issues. Their decisions are final. This committee will be made up of the Ag Education teachers from Plevna and Baker, County Agent, 4-H Assistant and the Fallon County Livestock/Barn Superintendent.
31. All animals can be removed from the barns and fair at 3:00 p.m. Sunday. Exhibitors have until 6:00 p.m. to remove animals from the barn.
32. There will be one class for a Pen of Three in the Market Animal classes. This includes alternate animals (Market: sheep, beef or swine).
33. The last year a Fallon or Carter County 4-H and FFA member will be allowed to show and sell is immediately following their year of high school graduation.

ALL OUTDOOR ANIMAL PROJECTS - DEPARTMENT P

DIVISION 1 - BEEF

DIVISION 1A - Market Beef (Points 10, 5, 3)

- Only open to Fallon County 4-H and FFA members.
- This class is open to any beef breed or crossbreeds.
- Animals must have been owned and fed by the exhibitor since January 1st of the current year.
- No milk in any form shall have been fed to the animals 90 days prior to the showing.
- Every animal will receive a ribbon based on grade and yield at the discretion of the judge. White-ribbon animals shall be designated as unfinished and not salable as market animals.
- All animals shown must be halter-broke and shown in the ring.
- Carcass evaluation using Montana Steer of Merit measurements will be attempted on as many steers as possible depending on date and location of slaughter.
- The Grand Champion Market Beef animal and the Reserve Champion Market Beef animal are eligible to compete in the Champion of Champions contest at the Eastern Montana Fair.
- The dress code for showing beef cattle and breeding cattle is long-sleeved white or solid-colored shirt and dark brown, black or blue jeans, boots and western hat or bareheaded – no caps allowed. The wearing of a tie or organizational scarf is preferred.
- All Market Beef entries are required to have a Bill of Sale. The Bill of Sale must be turned in at the time of weighing the animal for the fair competition.
- Feeder or market beef status of beef entry will be determined at the time of weigh-in. Beef less than 900 pounds will be considered feeder beef.

CLASS NO.

1. Market Beef
2. Pen of three market beef: Individual, Family, or Club
3. Feeder beef born during the current year's calving season.

DIVISION 1B - Junior Stocker-Feeder Beef Calves (Points 6, 3, 1)

- Class open to members enrolled in the Junior Stocker-Feeder Beef project
- Entries are limited to steers and heifers
- Calves must be on fairgrounds by 1:00 p.m. Friday, and not leave until 6:00 p.m. Friday
- For additional rules, etc., refer to project guidelines

CLASS NO.

1. Stocker-Feeder Steers (born after February 1 of the current calendar year)
2. Stocker-Feeder Heifers (born after February 1 of the current calendar year)

DIVISION 1C - Beef Breeding Stock (Points 10, 5, 3)

- Beef-breeding animals must be in member's possession by June 1, of the current calendar year.
- All lots in each breed will enter the ring at once and be judged in the order of ages.
- Champion of each lot will remain in the ring for Best-of-Breed judging. Best of each breed will return for overall-female champion at the end of the judging.
- Beef dairy cows will qualify for Crossbred female.
- Only purebred animals can be entered as exhibits in Classes 1 – 16.
- Crossbred animals are exhibits in Classes 17 – 28.
- The top breeding yearling heifer in each breed is eligible for the overall Heifer Trophy.
- The top cow/calf pair in each breed is eligible for the over-all cow/calf trophy.
- A cow with an adopted calf may be shown, if the birth calf of project animal has died.
- PLEASE NOTE: There is no bull to be shown in 4-H unless shown as a calf when accompanying the mother in one of the above classes.



CLASS NO.

	Yearling	2 yr old with calf	3 yr old with calf	Aged cow, 4 years & over with calf
Hereford female	1	2	3	4
Angus female	5	6	7	8
Gelbvieh	9	10	11	12
Simmental	13	14	15	16
Crossbreed	17	18	19	20
Other Exotic	21	22	23	24
Other English	25	26	27	28

DIVISION 2 - CAT (Points 8, 4, 2)

- A current vaccination record must be attached to the entry form or the cat will not be allowed to show.
- This class is open to all cats - mixed and pure breeds.
- Cats are not to stay on the fairgrounds. Cats are brought to the fairgrounds for the judging only, then removed.

CLASS NO.

1. Cat, 3 months to 1 year, health and grooming
2. Cat, over 1 year old, health and grooming



DIVISION 3 - DAIRY CATTLE (Points 10, 5, 3)

Animals in dairy classes will be judged on size for age, dairy type, vigor, condition, and milk producing characteristics.

DIVISION 3A - Dairy Animal Exhibits

CLASS NO.

	Heifers under 1 year	Heifers under 2 & over 1 year	Cows over 2 & under 3 years	Cows 3 & not over 4 years
Holstein	1	2	3	4
Jersey	5	6	7	8
Guernsey	9	10	11	12
Brown Swiss	13	14	15	16
Other	17	18	19	20
Crossbred (Must be dairy-breed cross)	21	22	23	24

CLASS NO.25. Dairy cow and calf at her side (Neither animal may be shown in Classes 1-24)

DIVISION 4 – DOG

- A current vaccination record must be attached to entry form or dog will not be allowed to show
- Dogs are not to stay on the fairgrounds. Dogs are brought to the fairgrounds for the judging only, then removed.
- The conformation of the dog is not considered, but only the ability to present the dog to the judge.
- Dogs must be shown with proper lead and be groomed and clean.
- This Division is open to all 4-H Project Dogs - mixed and pure breeds.

DIVISION 4A - Dog Obedience (Points 8, 4, 2)

- All done on leash of 8 – 10 ft in length
- Level you exhibit in is based on ribbon placing of past performances of your dog and yourself working together as a team, not the level you are enrolled in. Your dog leader will inform you what level you are to exhibit in prior to the fair.

CLASS NO.

1. Beginner A
1. Beginner B
3. Graduate Beginner
4. Novice
5. Graduate Novice

**See “Basic Companion Dog Manners & Obedience Manual”*

DIVISION 4B - Dog Agility (Points 8, 4, 2)

CLASS NO.

1. Beginner
2. Elementary
3. Intermediate
4. Senior
5. Advanced

**See “Basic Companion Dog Manners & Obedience Manual”*

DIVISION 5 - GOATS

OVERALL GOAT GUIDELINES

- All goats must be clean and show ready. Members must fit or contribute to the fitting of their own animals.
- All exhibitors will adhere to the official 4-H and FFA dress code.
- A long sleeved white or solid colored shirt & dark brown, black or blue jeans, boots & western hat (or bareheaded); no caps allowed. No tennis shoes or thongs will be allowed.

- FFA members must follow official FFA dress code. If dress code is not followed the contestant will be dropped a ribbon placing.
- Members must have possession of their animals by June 1st.
- Collars are the only acceptable means under which goats may be shown.
- Animals must be shown in their respective classes before they are eligible to be shown in Dam & Daughter.
- Dam & Daughter class will consist of biological dam and daughter. The objective in this class is to show you have improved on the conformation of offspring.
- Any animal showing signs of disease, emaciation, warts, ringworm, abscess (caseous lymphadenitis) or other skin conditions or unsightly blemishes will be refused.
- All animals must be completely healed from disbudding or dehorning. No horned animals will be allowed to show with the exception of Fiber Goat breeds. Small scurs are not desirable but will be allowed.
- No males will be shown. No males of breeding age (over 2 months) will be allowed on the fairgrounds. If a male is castrated, they must be completely healed.

DIVISION 5A - Dairy Goat (Points 10, 5, 3)

CLASS NO.

	Under 6 months	6 mo. - 1yr.	1 - 2 years	2 + years
Swiss (Alpine, Saanen, Toggen., etc.)	1	2	3	4
Nubian	5	6	7	8
LaMancha	9	10	11	12
Crossbred	13	14	15	16
Dam & Daughter	17			
Get of Sire	18			

DIVISION 5B – Market Goats (Points 10,5,3)

- Market Goat guidelines in addition to Overall Goat Guidelines will be followed.
- This class is open to mixed or pure-bred goats born prior to June 1 of the current year.
- Members must have possession of animals by June 1.
- Males must be castrated and completely healed.
- Exhibitors must adhere to official 4-H or FFA dress code.
- Goat will be sold by the head and not by weight at the Market Sale.

CLASS NO.

1. Market Goat

DIVISION 5C – Nondairy Breeding (Points 10,5,3)

- Will follow Overall Goat Guidelines

CLASS NO.

	Doe under 1 year	Doe 1 year - 2 years	Doe 2 + years
Angora (any fiber)	1	2	3
Boer	4	5	6
Pygmy	7	8	9
Crossbred	10	11	12
Other	13	14	15

DIVISION 5D – Pack Goat Project (Points 10,5,3)

- Class is open to doe or wether goats of any breed born prior to and in possession prior to June 1, of the current year. Wethers must be healed after castration.
- Exhibitors must adhere to the official 4-H or FFA dress code.
- A goat used in the obstacle course must be entered in a Dairy, Pygmy, Fiber, Meat, Harness, or Obstacle Course
- Lead and halter or collar are permitted. If led with collar and lead, collar will not be touched. Doing so will result in a loss of points.
- Course will be timed to help ascertain the winner.
- Course may include, but is not limited to: walking over several logs, a bridge, water obstacle, cones, and poles.

- Weight of packs and items not to exceed 25% of the weight of a “Well Conditioned” adult goat, and not to exceed 10% of the weight of a kid goat. Example: 10% of a kid goat weighing 35 lbs. by the current fair year is 3.5 Lbs. A well conditioned adult goat weighing 150 lbs. by July 15 of the current fair year can carry 37.50 lbs.
- All packs and goats must be weighed by goat leader by July 15 of the current fair year. Call in advance for appointment.
- Goat is to be led in and then stand while the packs or pack saddle is put on and loaded. A helper in this area is permissible. Then the goat will be lead around the course. Difficulty, of course, will be dependent on goat and handler maturity.

CLASS NO.

1. Goat competing for first or second year.
 2. Goat competing for third or fourth year.
 3. Goat competing for five years or more.
- *Goat competing for five years or more may show with voice command only if so wishes.*

DIVISION 5E – Obstacle Course (Points 8,4,2)

- This class is open to doe or wether goats.
- The goat being used for obstacle must also be entered in one of the other goat classes: Dairy Breeding, Fiber Breeding, Miniature Goat Breeding, Meat Breeding, Driving/harness, Market or Packing class.
- Exhibitor will adhere to official 4-H or FFA dress code.
- Goat is to be shown by lead and collar or halter and lead. Goat is to be led by lead only. If collar is touched, a loss in points will result.
- Novice Graduate members may show with voice command only, if so wishes, but goat must be under control at all times.
- Obstacles may include, but are not limited to: stairs, teeter-totter, log jump, barrel, and high jump.
- Time limit is set dependent upon the course and is set prior to the class by the judge and goat committee.
- All new goats will start as first year beginners.

CLASS NO.

1. Beginner – members competing in obstacle for the first and second year.
2. Novice – members competing in obstacle for the third and fourth year.
3. Novice Graduate – members competing in obstacle for the fifth year or more.

DIVISION 5F – Goat Driving/Harness (Points 10,5,3)

The harness goat project is a multi-year project.

The first year of the project, the exhibitor can take a kid in the harness kid class or first year.

The second year the animal can come back as a harness yearling. The third and succeeding years, the goat is in the senior harness class. The exhibitor must begin with the first year project. The harness goats will be judged on the following: the level of the class should deal with the level of the goat, not it's age.

- This class is open to doe or wether goats of all breeds, and in possession prior to June 1 of the current year.
- All goats must begin at First Year, regardless of age.
- Harness must not exceed 25% of adult goat weight.
- Advancement between the years must be approved by goat leaders for safety reasons.
- All equipment used on goats must be checked by leaders for safety, proper fit and cleanliness.
- If Pygmy Goats are being used, they must begin to be trained as a team beginning with first year.

- All carts, 2 wheel as well as 4 wheel are not to exceed 100 lbs. and must be in proper, clean and safe working order.
- Rider and goat must compete against any and all goats in their lot.
- Proper control must be maintained at all times.
- Once a member and goat has completed all before mentioned years and has passed assessments to the satisfaction of harness goat leaders, member may assess to drive a team of goats. Team must be reasonably matched in size and weight and compatibility.
- Assessments and weigh-ins must be arranged with goat leaders and completed by July 15 of the current year to participate in fair in each level.

CLASS NO.

1. First Year
2. Second Year
3. Third Year

JUDGING

Judging will be done on a point system with the following points:

1. Appearance of animal – 20 points
2. Appearance of exhibitor – 20 points
3. Overall appearance of cart and harness – 20 points
4. Performance of animal in show ring (following commands) – 40 points



DIVISION 6 - HORSES

FALLON COUNTY HORSE FAIR RULES

4-H and FFA Horse Classes will be judged on Wednesday beginning at 8:00 a.m.

1. All animals shown by 4-H members in 4-H classes must be owned by the member or in partnership with immediate family or the member must have access to the horse May 1 through the county fair.
2. Stallions may not be shown in any class with the only exception being a yearling in the Horse Training Project.
3. One horse can be shown by two members if in different classes.
4. The Best of Class in Horsemanship 1 & 2 at the Fallon County Fair would need to advance. Members in Horsemanship Levels 3-6 would need to advance after receiving 2 Best of Classes at the county level or 1 Grand Champion at the state level.
5. Members must compete in the most advanced level they are taking.
6. Horses may be shown two handed in a snaffle bit or hackamore. Horses shown in a curb bit must be shown one handed. A legal curb bit is any curb bit with solid or broken mouth piece. Mouth piece must be smooth where it comes in contact with horse's lips or bars, no protrusion below the mouth piece. Curb straps must be ½" wide and lay flat against the horse's chin.
7. Showmanship, Bareback Equitation and Trail are non-project classes and will be open to all horse project members at the Fair. To compete in these classes, the member must use a horse they have chosen to compete with in project classes at the fair.
8. Horses may be removed from the fairgrounds at 3:00 pm on Sunday.
9. Each 4-H Horsemanship Project member must identify their horses by May 1 of the current 4-H year. Records must be kept on all horses with ID's turned in. Identified Horsemanship horses will be eligible to be used by other 4-H Horsemanship members.
10. All horses in showmanship will be shown on halters only.

11. Horses will be housed in the stalls behind the bleachers of the Livestock Pavilion. Members are encouraged to decorate their stalls.
12. Horses must be exercised each morning and night.
13. Stalls must be cleaned by 7:45 a.m. each morning.

GENERAL DRESS CODE FOR ALL CLASSES

Western:

- Long sleeved, button or snap, plain white or off-white blouse or shirt (no contrasting colors can be present on the shirt)
- Western type pants
- Western boots and western type hat (felt or straw) or helmet
- Vests, sweaters and jackets are prohibited
- Chaps, gloves and ties are optional
- Spurs are optional unless otherwise prohibited
- Hair that is shoulder length or longer must be contained in a net or braid while showing in the project or showmanship classes

English:

- Hunt type - Hunt coat (red, pink or scarlet coats prohibited unless exhibitor has earned them as a member of a recognized hunt)
- Breeches
- Hunt boots
- Hard hat with leather-type-chin strap for hunter type classes
- Stock, chokers, or ties required
- Gloves optional
- Hair that is shoulder length or longer must be contained in a net or braid.
- Note: English jackets and/or vests may not be worn in halter, showmanship or bareback classes. Solid-colored long-sleeved blouse or shirt appropriate with English attire must be worn.

WESTERN JUDGING CRITERIA

Walk:

- Good - ground covering, flat footed, good attitude
- Minor faults - slow, disinterested, not attentive
- Major faults - nervous, jiggling
- Disqualification - not walking

Jog:

- Good - easy riding, good motion, consistent, steady
- Minor faults - too slow, too fast
- Major faults - not performing a two-beat jog, failing to jog both front and back, hard or rough riding
- Disqualification - constant breaking

Lope:

- (Cannot extend)
- Good - easy riding, good motion, consistent, steady
- Minor faults - too slow, too fast
- Major faults - wrong lead, pulling, trotting behind, hard or rough riding
- Disqualification - Not under control

Extended Jog:

- Good - easy riding, good motion, smooth, consistent
- Minor faults - inconsistent speed
- Major faults - breaking gaits, pulling, hard or rough riding
- Disqualification - no increase in speed

Back:

- Good - proper flexion, readily responsive, back in straight line
- Minor faults - hesitant, not backing straight
- Major faults - throwing head, gaping, pulling
- Disqualification - not backing, rearing

General:

- Good - smooth, steady, easy riding, proper flexion and balance, good attitude
- Minor faults - over or under flexion, sour ears, switching tail, inconsistent speed, out of balance, poll too high or too low to throw horse out of balance, improper or incomplete appointments
- Major faults - throwing head, bad mouth, constant bumping the bit, gaping, evidence of altered tail carriage, obvious schooling
- Disqualifications - constant breaking of gaits, two hands on reins unless using a snaffle bit or hackamore (bosal), kicking, illegal equipment, lameness, cuing horse in front of cinch, fall of horse or rider

GENERAL REQUIREMENTS FOR RIDING CLASSES

Entries must be shown in a stock saddle. Tie-downs, martingales, and mechanical hackamores of any type are prohibited unless other-wise indicated in class description. Split or Romal reins are permissible, but roping reins are not allowed. Spurs are optional. Spurs should not be used forward of the cinch. In all classes, the judge has the option of requesting one or all contestants to perform individually.

FALLON COUNTY FAIR HORSE JUDGING SCHEDULE

WED. 6:00 AM Horses may enter the barn
8:00 AM Senior Horse Showmanship
Junior Horse Showmanship
Novice Horse Showmanship
10 – 15 Minute Warm-up
Yearling
Senior Bareback
Junior Bareback
Level 1 Horsemanship
Level 2 Horsemanship
Level 3 Horsemanship
Level 4 Horsemanship
Level 5 Horsemanship
Level 6 Horsemanship
Level 7 Horsemanship
Horse Breeding
Colt to Maturity Training 2 year old
Colt to Maturity Training 3 year old
Colt to Maturity Training 4 year old
Colt to Maturity Training 5 year old
Level 1 Green Horse
Level 2 Green Horse
Level 3 Green Horse
Level 4 Green Horse
Level 1 English Horsemanship
Level 2 English Horsemanship
Level 3 English Horsemanship
Hunt Seat Equitation Over Fences
Ranch Horse
Yearling Trail Class
Senior Trail Class
Junior Trail Class
Driving

**A lunch break of one hour will be taken at approximately 12:00 noon.
This schedule is subject to change without notice.**

DIVISION 6 - HORSEMANSHIP (Points 10, 5, 3)

**Refer to Introduction to Horsemanship Manual I-III, 5246 and Montana 4-H Horsemanship Project Manual, C1160*

** Must be enrolled in the Horsemanship Project to be eligible to compete in this class.*

DIVISION 6A - Level I

CLASS NO.

1. The horse will be judged at a walk and/or trot both ways of the ring. One or more contestants may be asked to dismount and mount.

DIVISION 6B - Level II

CLASS NO.

1. The horse will be judged at a walk, trot and canter, both ways of the ring. Riders must be able to identify correct leads, not perform them. One or more contestants may be asked to:

Perform any tasks in Level I

Back your horse six steps, while mounted

Name the parts of the horse and/or tack

Demonstrate the left and/or right lead

Move from a walk to a trot to a lope back to a trot then a walk both directions of the arena

For All Working Patterns

- The arena or plot should be approximately 50 x 150 feet in size.
- The judge will indicate where the mandatory markers are to be placed on the fence or arena wall.
- Large "X" indicates where mandatory markers are to be placed.

DIVISION 6C - Level III

CLASS NO.

1. The horse will be judged at a walk, trot and lope both ways of the ring using the correct lead. Trot or lope in a straight line around a pylon without breaking gait, return in a straight line and back your horse 10 steps while mounted. One or more contestants may be asked to:

Perform any tasks in Levels I and II

Demonstrate how to pick up all four feet

Perform Pattern #1 at the discretion of the judge

Pattern #1

Horsemanship III (Western)

1. Walk to marker **A**. Pick up jog, jog to middle of arena. Pick up right lead and lope circle. Near center of arena break to a jog. Jog through center of arena then pick up a left lead and lope a circle.
2. After completing left circle jog to and around markers **B** and **A**.
3. Continue jogging towards judge. When near judge slow to a walk then stop. Settle horse. Back your horse 8 steps.

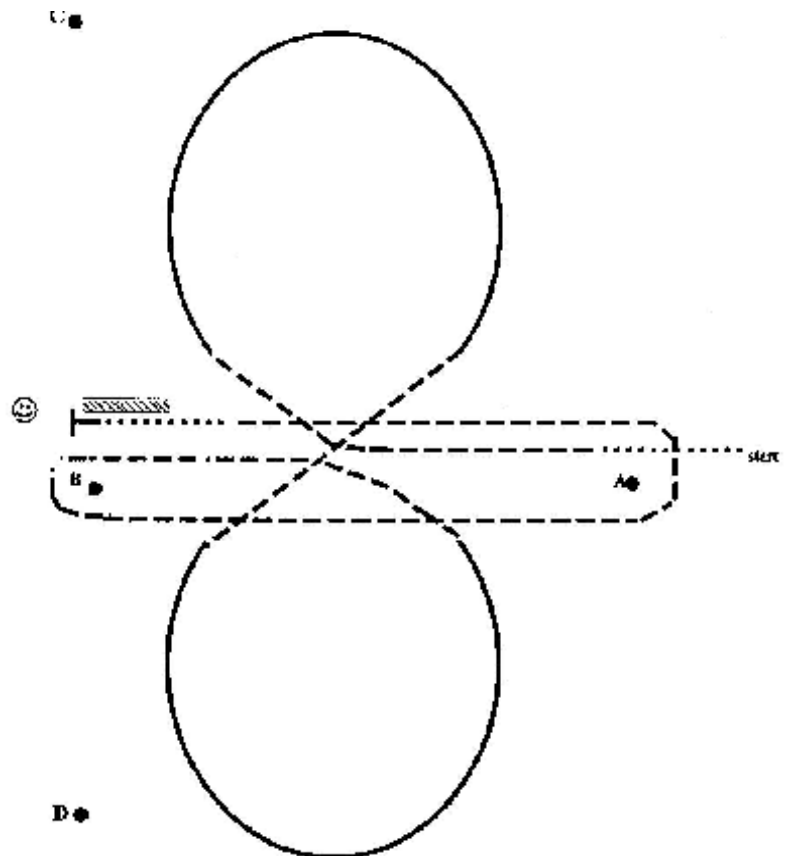

DIVISION 6D - Level IV

CLASS NO.

1. Contestants will be judged on their ability to perform Pattern #2 and perform any tasks in Levels I, II, and III.

PATTERN #2

1. Make two figure eights at a lope, with a simple lead change (drop to a trot) - start with right lead.
2. Go to one end of the arena. Walk a straight line.
3. From a standing start, lope to the other end of the arena.
4. Make a rollback toward the judge.
5. Come out of the rollback at a lope to the other end of the arena.
6. Again rollback toward the judge.
7. Come out of the rollback smoothly at a lope.
8. Make a smooth stop in the center of the arena and then back the horse 15 feet in a straight line.
9. Move forward to the judge for final instructions.

PATTERN #2

Horsemanship IV Western)

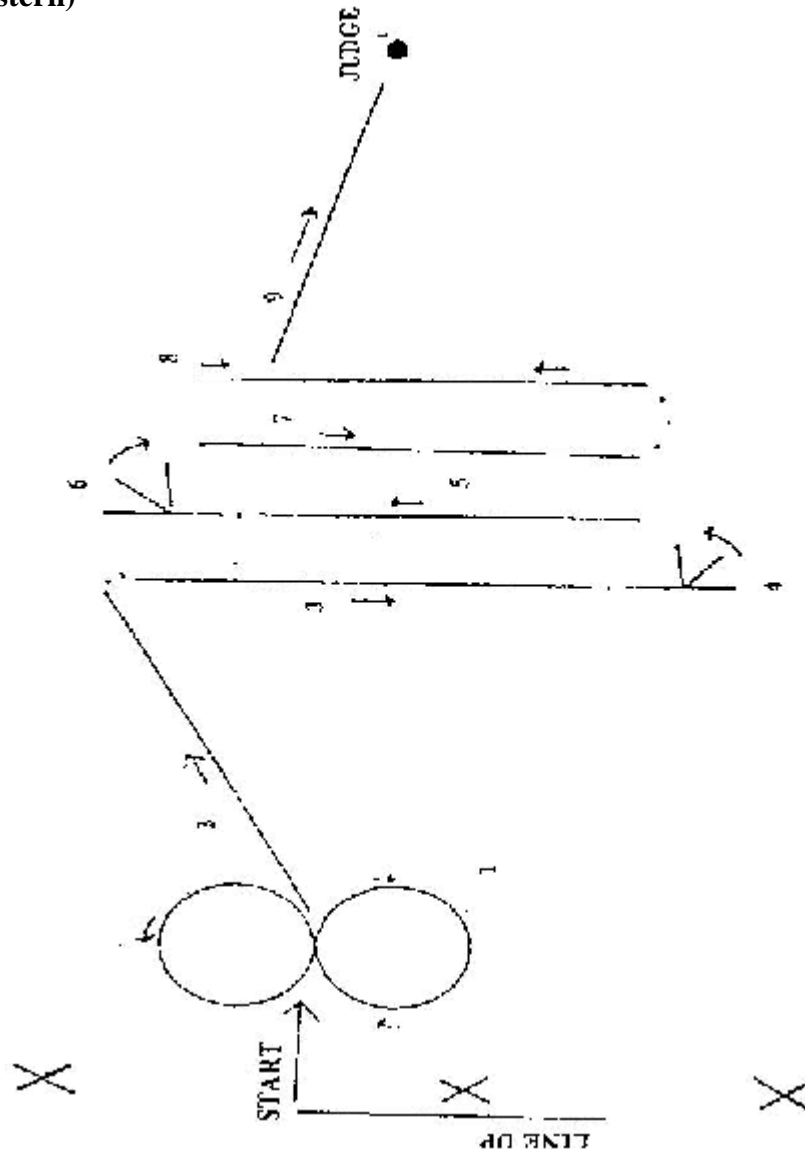

DIVISION 6E -Level V

CLASS NO.

1. Perform any tasks in Levels I, II, III and IV.

The horse will be judged on his ability to perform Pattern #3

PATTERN #3

1. Start at marker **B**. Sidepass to the left and right, 10 feet each way.
2. Jog to center. Pick up left lead to start figure 8 with a simple lead change in the middle.
3. After completion of figure 8 jog to judge and stop. Settle. Do a 180° hindquarter pivot right and left.
4. Jog around marker **C** halfway to marker **D** and stop. Do a 180° forehand turn right and left.
5. Jog to corner around marker **D**. Extend trot to and around marker **E** and to marker **C**. Stop.

PATTERN #3

Horsemanship V (Western)

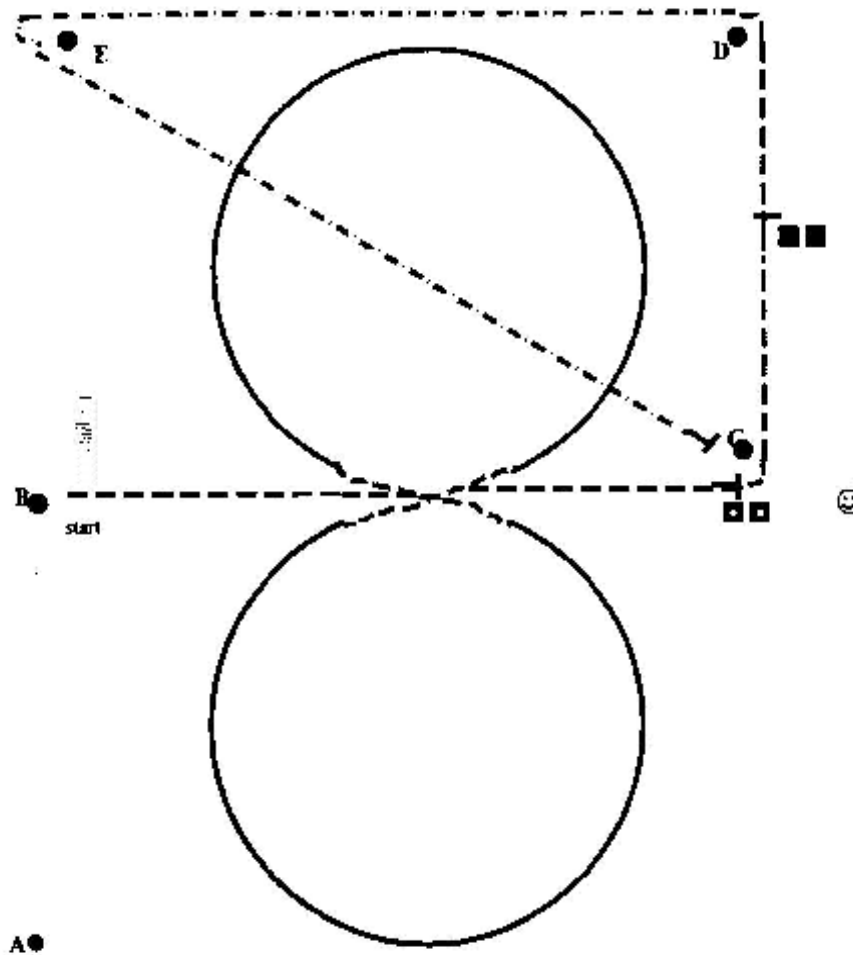

DIVISION 6F - Level VI

CLASS NO.

1. Perform any tasks in Levels I, II, III, IV and V.

The horse will be judged on his ability to perform Pattern #4.

PATTERN #4

1. Hindquarter turn 360° right.
2. Right lead.
3. Trot.
4. Trot.
5. Left lead.
6. Trot.
7. Stop.
8. Hindquarter turn 180° left.
9. Left lead.
10. Change right lead.
11. Change left lead.
12. Change right lead.
13. Trot.
14. Two track to right.
15. Two track to left.
16. Stop.
17. Back the horse 8 feet.

PATTERN #4

Horsemanship VI (Western)

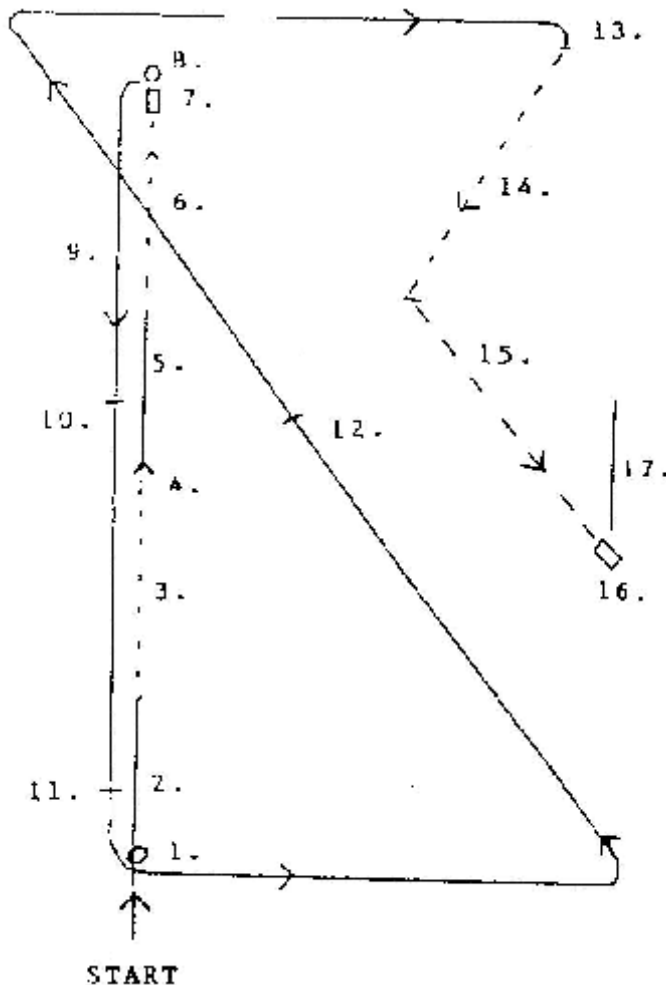

DIVISION 6G - Level VII

CLASS NO.

1. Required mounted abilities.

- Rider to execute the pattern using skills from required mounted abilities from Level 6.
- Pattern to be developed by rider and submitted with registration and entry.
- It will be provided to Judge before the class begins.
- Patterns may be choreographed to music.
- Single exhibitor and horse to perform pattern.
- Set-up time, performance of pattern, and tear down time not to exceed 4 minutes. Time limit will be enforced.

DIVISION 6H - Horse Breeding (Points 10, 5, 3)

- The dam and offspring need to be biologically related.
- The dam and offspring need to be present for judging only. They may be returned home, not kept on the fairgrounds unless prior arrangements have made and approved of.
- The offspring would have been born on or after January 1st of the current year.
- Must be enrolled in the Horse Breeding Project to be eligible to compete in this class.

CLASS NO.

1. Dam and Offspring (The objective of this class is to show member has improved on the conformation of offspring.)

DIVISION 6I - Training a Colt to Maturity (Points 10, 5, 3)

Refer to Bulletin 353 "Training Horses -Yearling to 5 Year Old" for additional requirements.

Must be enrolled in the Colt to Maturity Project to be eligible to compete in this class.

CLASS NO.

1. Yearling

- Each club member will show his or her colt while standing at the walk, at the trot, backing and be able to pick up all four feet. Refer to Montana 4-H Showmanship Guide, Circular 1287. May be shown in Western or English attire and tack.

2. Two-Year-Old Under Saddle - Western

- Open only to two-year-old fillies and geldings. Animal will show best with a ring snaffle bit, or a rawhide hackamore (bosal). The use of running martingale or German Olympic martingale is permissible, but not mandatory. Other martingales, tie downs and bits are not permitted (shank bits are not permitted).
- For other equipment, refer to "General Requirements".
- Horses will be direct reined only (rein held in each hand).
- Horses will be judged at the walk, trot and lope both directions of the ring.
- Perform Pattern # 5.
- Other tasks the contestant may be asked to perform are:
Halt (not sliding stop) from the walk
Dismount and mount
Unsaddle and saddle up
Back while dismounted
Parts of the animal, equipment and nutrition
- Judges is not to ask members to perform tasks not listed above or tasks not included in the pattern.

PATTERN #5

Two-Year-Old Under Saddle

- Enter ring counter clockwise at a walk at judge's direction; increase to a trot, maintain until judge asks to increase to a lope (canter), hold until judge asks you to trot then to walk. Switch directions turning toward judge and repeat. Halt from a walk at judge's direction.

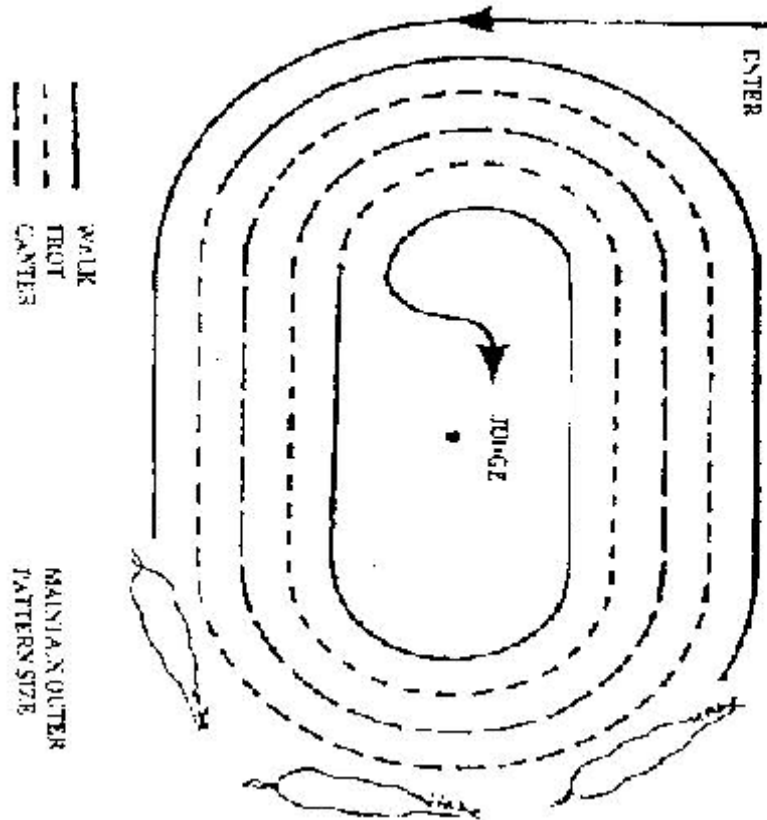

CLASS NO.

3. Three-Year-Old Under Saddle - Western

- Open only to three-year-old mares and geldings. Animal will show best ridden 2 handed with a ring snaffle bit, or a rawhide noseband hackamore (bosal). The use of a German Olympic martingale or running martingale is recommended but not mandatory. Other martingales, tie downs and bits are not permitted. (shank bits are not permitted)
- For other equipment, refer to "General Requirements".
- Horses may be neck reined or direct reined. Either method is acceptable; no additional credit will be given for neck reining. Spurs should not be used forward of the cinch.
- Horses will be judged at the walk, jog, lope on the rail both directions and lengthen and reduce each gait as directed by the judge. Each individual will also be judged on Pattern #6.
- Other tasks the contestant may be asked to perform are:
 - Requirements from Class I and Class 2
 - Identify leads
 - Parts of animal, equipment and nutrition
- Judge is not to ask members to perform tasks not listed above or tasks not included in the pattern.

PATTERN #6

Retire to one end of the arena where each rider will perform the following-pattern individually:

- 1-2. Trot along side of fence about 100 feet
2. Stop
- 2-3. Turn on forehand (front feet stay in two foot circle) with hindquarter moving to the right
- 3-4. Trot back toward starting point along the fence
4. Stop
- 4-5. Turn on the forehand (keep front feet in two foot circle) with hindquarter moving to the left
- 5-6. Trot along fence striking into a lope as the rider begins the Figure 8 and go around Circle A once at the lope
7. Drop to a trot
8. Pick up new lead and go around Circle B at the lope
9. Drop to a trot
10. Pick up new lead and go around Circle A
11. Drop to a trot
12. Pick up new lead and go around Circle B
- 13-14. Trot to the left making the circle progressively smaller drawing down to three circles until the horse is holding hindquarters in one spot and crossing his front legs to walk around 180° turn
- 14-15. Trot to right making the circle progressively smaller drawing down to three circles until horse is holding hindquarters in one spot and crossing his front legs to walk around 180° turn
- 15-16. Trot
16. Stop
- 16-17. Back 10 feet
17. Stop, settle horse for 10 seconds
18. Retire to judge for inspection

PATTERN #6

Three year old under saddle (Western)

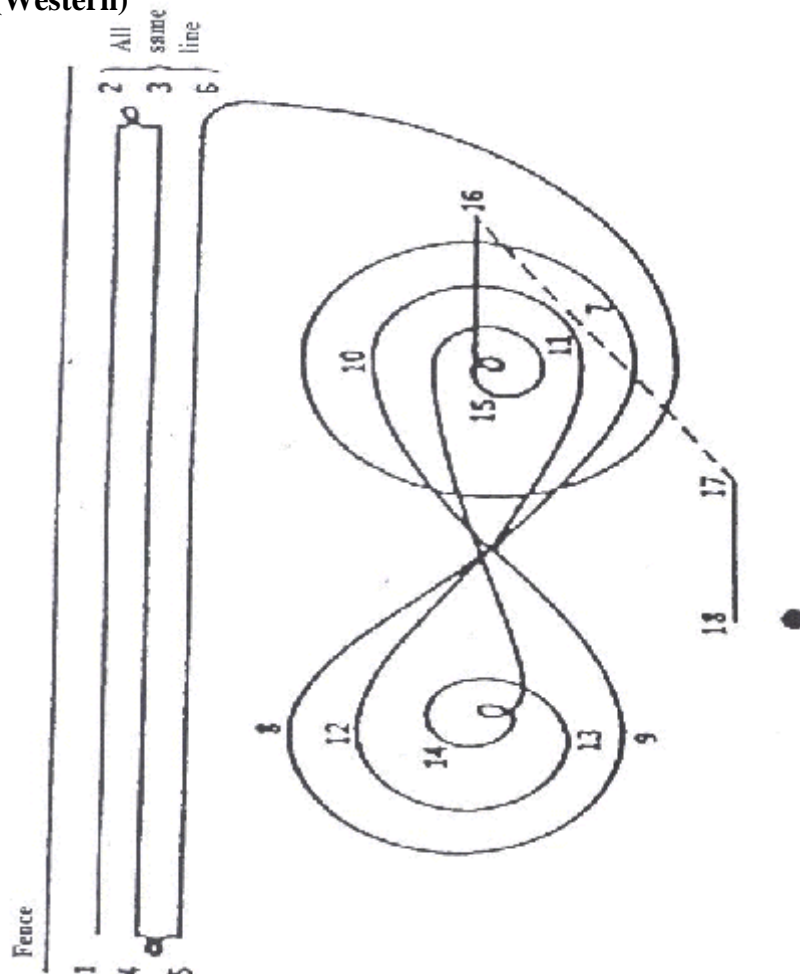

CLASS NO.

4. Four-Year-Old Under Saddle – Western

Open to four-year-old mares and geldings. Animal will show best with a ring snaffle bit or rawhide noseband hackamore (bosal) using two hands; however, if a contestant desires a curb bit, one hand can be used. The use of a German Olympic martingale or running martingale, may be used when using a ring snaffle only, but it is not mandatory. However, other martingales and tie downs are not permitted.

- For other equipment, refer to "General Requirements".
- Horses may be neck reined or direct reined. Either method is acceptable and no additional credit will be given for neck reining.
- Horses will be judged at the walk, jog, lope on the rail both directions and lengthen and reduce each gait as directed by the judge. Rider may post the extended trot, but must sit the jog trot. Each individual will also be judged on Pattern #7.
- Other tasks the contestant may be asked to perform are:
 - Requirements from Lots 2 and 3
 - Parts of the animal, equipment and nutrition
- Judge is not to ask members to perform tasks not listed above or tasks not included in the pattern

PATTERN #7

Retire to one end of the arena where each rider will perform the following pattern individually:

- 1-2. Trot straight ahead, sitting the trot, 25 feet
- 2-3. Side pass to the left - 15 feet - at the walk
- 3-4. Trot straight ahead, sitting the trot
- 4-5. Side pass to the right - 15 feet - at the walk
5. Strike off the right lead
- 5-6. Lope in right lead - 30 feet
6. Stop, settle horse
- 6-7. Strike off left lead - 30 feet
7. Stop, settle horse
- 7-8. Strike off right lead - 30 feet
8. Stop, settle horse
- 8-9. Strike off left lead - 30 feet
- 9-10. Backing horse - 10 to 12 feet
- 10-11. Trot to the left making circle progressively smaller and smaller until horse is holding hindquarters in one spot and crossing his front legs to walk around a complete 360°
- 11-12. Trot a circle to the right making it progressively smaller until horse is holding his hindquarters in one spot, crossing his front legs to walk around a complete 360°
- 12-13. Walk horse - 20 feet
13. Stop
- 13-14. Turn left on the haunch with horse crossing his front legs to walk 180°
- 14-15. Turn right on the haunch with horse crossing his front legs to walk 180°
- 15-16. Retire the arena

PATTERN #7

Four year old under saddle (Western)

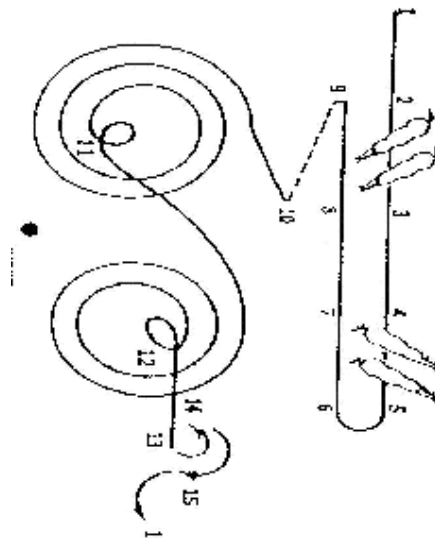

CLASS NO.

5. Five-Year-Old Under Saddle - Western

- Open to five-year-old mares and geldings. Horse will show in a curb bit. Skid boots are optional for sliding stop.
- For other equipment, refer to "General Requirements".
- Horse must be neck reined.
- The horse will be judged on his ability to quietly and accurately perform the designated pattern. For riding pattern and explanation, see Pattern #8. Follow the explanation for Western Riding Pattern.
- Judges is not to ask members to perform tasks not listed above or tasks not included in the pattern

PATTERN #8

For Western Ride Pattern:

1. Starting in the center of the arena make a large fast circle to the right.
2. Make three circles to a small circle until you reach the center of the arena. Stop.
3. Do a double spin (720°) to the inside of the small circle in the center of the arena - at the end of the spins, the horse should be facing in direction from where started spin.
4. Begin on the left lead and make a large fast circle
5. Make three circles again drawing it down to the center of the arena - stop - no hesitation on these stops
6. Do a double spin (720°) to the inside of the circle - slight hesitation - horse to be facing direction from where spin started
7. Begin on right lead and make a fast figure eight over the large circle - close the eight - and change leads.
8. Run to far end of the arena and do a left roll back
9. Run to opposite end of arena and do a right roll back
10. Run back past center of the arena and do a sliding stop - Hesitate
11. Back over slide tracks
12. Finish - walk to judge for inspection and dismissal

PATTERN #8

Five-Year-Old Under Saddle - Western

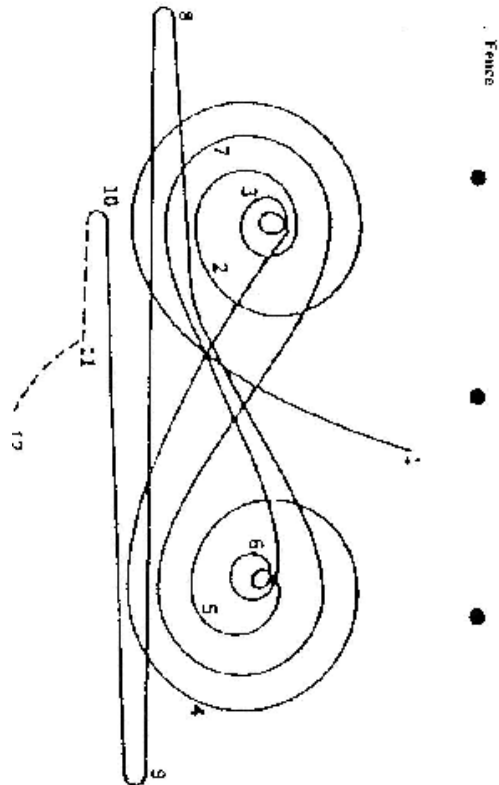

DIVISION 6J - Green Horse (Points 10, 5, 3)

This project is for members who have horses that are not fully trained, but do not fit into the Colt-to-Maturity Project because of age or ability. Open only to mares and geldings.

CLASS NO. 1 - Level I

- Animal will show best with a ring snaffle bit or a rawhide hackamore (bosal). The use of running martingale or German Olympic martingale is permissible, but not mandatory. Other martingales, tie downs and bits are not permitted (shank bits are not permitted).
- Horses will be direct reined only (rein held in each hand).
- Horses will be judged on ability to perform **Pattern #5**.
- Other tasks the contestants may be asked to perform are:
 - Halt (not sliding stop)
 - Dismount and mount
 - Unsaddle and saddle up
 - Back while dismounted
 - Name parts of animal, equipment and nutrition

CLASS NO. 2 - Level II

- Animal will show best with a ring snaffle bit or a rawhide hackamore (bosal). The use of running martingale or German Olympic martingale is permissible, but not mandatory. Other martingales, tie downs and bits are not permitted (shank bits are not permitted).
- Horses may be neck reined or direct reined. Either method is acceptable; no additional credit will be given for neck reining. Spurs should not be used forward of the cinch.
- Horses will be judged on Pattern #6.
- Other tasks the contestant may be asked to perform are:
 - Requirements from Class No.1
 - Identify leads

CLASS NO. 3 - Level III

- Animal will show best with a ring snaffle bit or a rawhide hackamore (bosal). The use of running martingale or German Olympic martingale is permissible, but not mandatory. Other martingales, tie downs and bits are not permitted (shank bits are not permitted)
- Horses may be neck reined or direct reined. Either method is acceptable; no additional credit will be given for neck reining.
- Horses will be judged at the walk, jog, lope on the rail both directions and lengthen and reduce each gait as directed by the judge. Rider may post the extended trot, but must sit the jog trot.
- Horses will be judged on ability to perform Pattern #7.

CLASS NO. 4 - Level IV

- Horse will show in a curb bit. Skid boots are optional for sliding stop.
- Horse must be neck reined.
- Horse will be judged on ability to quietly and accurately perform Pattern #8.

General Requirements for English Horsemanship Classes

- The horse may be entered in English Horsemanship, but in only one class of English. (If a horse is also entered in Western Horsemanship, it can only be a maximum of two (2) levels different - higher or lower.)
- Dress Code: See General Rules. Entries must be shown hunt seat. Spurs and crop are optional.
- Snaffle bit or other suitable English bits - Smooth snaffle bit with broken mouthpiece (conventional 0-ring, egg butt, or D-ring) with ring no larger than 4" and no smaller than 2". From the cheek to one inch in from the cheek must be a minimum 3/8" diameter with a gradual decrease to the center of the snaffle. Optional loose curb strap (leather or nylon only and must be attached below the reins).

English Judging Criteria

Walk:

- Good - brisk, flat footed, good attitude
- Minor faults - slow, disinterested, not attentive
- Major faults - nervous, jiggling
- Disqualifications - not walking

Trot:

- Good - balanced, free moving, consistent, steady
- Minor faults - too slow, too fast
- Major faults - not performing a two-beat trot, failing to trot both front and back, hard or rough riding
- Disqualification - constant breaking

Canter:

- Good - smooth, unhurried, consistent, steady
- Minor faults - too slow, too fast
- Major faults - strong lead, pulling, trotting behind, hard or rough riding
- Disqualification - not under control

Extended Trot/Canter:

- Good - strong, ground covering, smooth, consistent
- Minor faults - inconsistent speed
- Major faults - breaking gaits, pulling, hard or rough riding, uncontrolled
- Disqualification - no increase in speed

Back:

- Good - proper flexion, readily responsive, back in straight line
- Minor faults - hesitant, not backing straight
- Major faults - throwing head, gaping, pulling
- Disqualification - not backing, rearing

General:

- Good - smooth, steady, proper flexion and balance, good attitude
- Minor faults - over and under flexion, sour ears, switching tail, inconsistent speed, out of balance, poll too high or too low to throw horse out of balance, improper or incomplete appointments
- Major faults - throwing head, bad mouth, constant bumping the bit, gaping, evidence of altered tail carriage, obvious schooling
- Disqualification - constant breaking of gaits, kicking, illegal equipment, lameness, cuing horse in front of cinch, fall of horse or rider

DIVISION 6K - Horsemanship: English (Points 10, 5, 3)

See Horsemanship Manual Circular 1160 for class requirements.

CLASS NO. 1 - English Horsemanship I.

- The horse will be judged at a walk and/or trot; post when trot. Riders may be asked to back, dismount and mount, unsaddle and saddle and name parts of bridle and saddle. Riders may be asked to explain but not execute correct diagonals.

CLASS NO. 2 - English Horsemanship II

- Horse judged at walk, trot, extended trot, and canter using proper diagonals. Riders must be able to identify correct leads, not perform them. Riders may be asked to perform any task in English 1, name external anatomy, and/or diagonals.

CLASS NO. 3 - English Horsemanship III

- May be asked to perform any task in English I or II
- Horse will be judged at a walk, trot and canter both ways of the ring using the correct lead. Posting trot and/or canter in a straight line around a pylon without breaking gait and return in a straight line. Back horse 10 steps while mounted.

CLASS NO. 4 - English Horsemanship IV

- Judged on ability to perform Pattern #9.
- May be asked to perform any task in English I, II, or III.

PATTERN #9

1. Make two figure eights at the canter, with a simple lead change (drop to trot) - start with right lead.
2. Go to one end of arena. Walk a straight line.
3. From standing start, post a trot to other end of arena and halt.
4. Make a forehand turn toward judge.
5. Canter to the other end of the arena and halt.
6. Turn on haunch toward the judge.
7. Canter to center of arena.
8. Make a smooth halt in the center of the arena and then back the horse 15 feet in a straight line.
9. Move forward to the judge for final instructions.

PATTERN #9
English Horsemanship IV

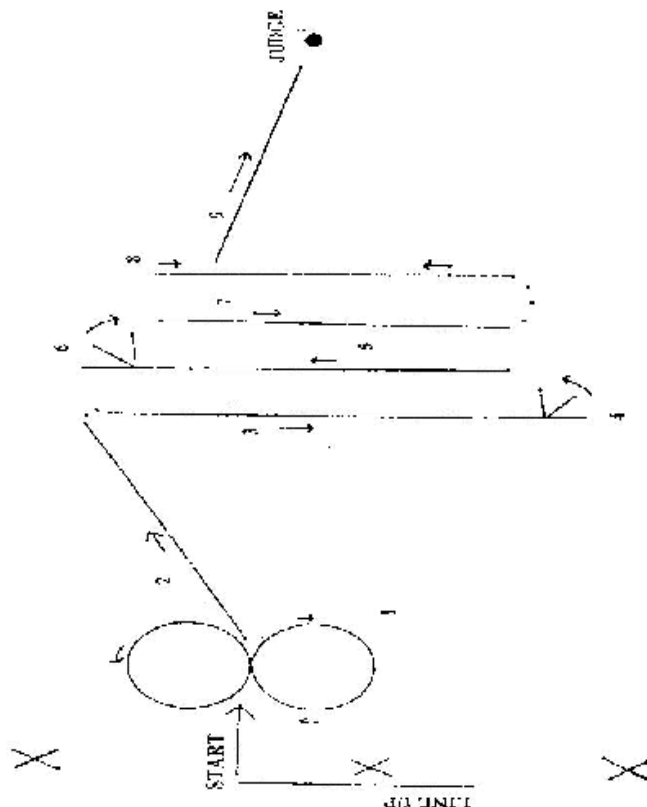

CLASS NO. 5 - English Horsemanship V

- Judged on ability to perform Pattern #10. May be asked to perform any tasks in Levels I, II, III, or IV.

PATTERN #10

English Horsemanship V

1. Walk
2. Collected sitting trot
3. Extended trot posting
4. Sitting trot
5. Canter right lead
6. Simple change left lead
7. Posting trot
8. Sit trot
9. Canter left lead
10. Simple change right lead
11. Simple change left lead
12. Sitting trot
13. Halt, turn on forehand 180° left, 180° right
14. Sitting trot
15. Halt, turn on haunch 180° right, 180° left
16. Settle 10 seconds
17. Retire to judge

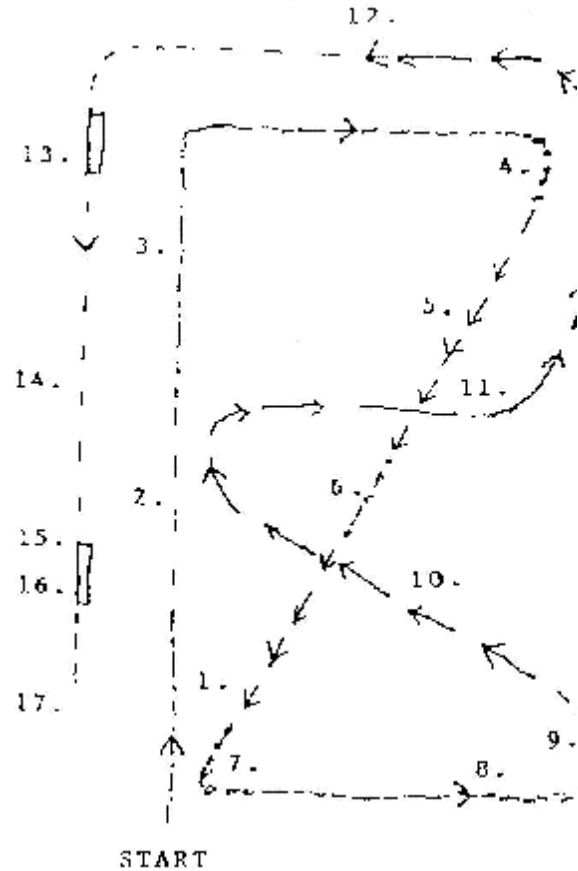

CLASS NO. 6 - English Horsemanship VI

- Judged on ability to perform Pattern #11. May be asked to perform any tasks in Levels I, II, III, IV, or V.

PATTERN #11

English Horsemanship VI

1. Turn on haunch 360° right
2. Right lead
3. Extended trot, left diagonal
4. Sit trot
5. Left lead
6. Extended trot, right diagonal
7. Halt
8. Turn on haunch left 180°
9. Left lead
10. Collected change right lead
11. Change to left lead
12. Collected change right lead
13. Drop to sitting trot
14. Two track to right
15. Two track to left
16. Halt
17. Back the horse 8 feet

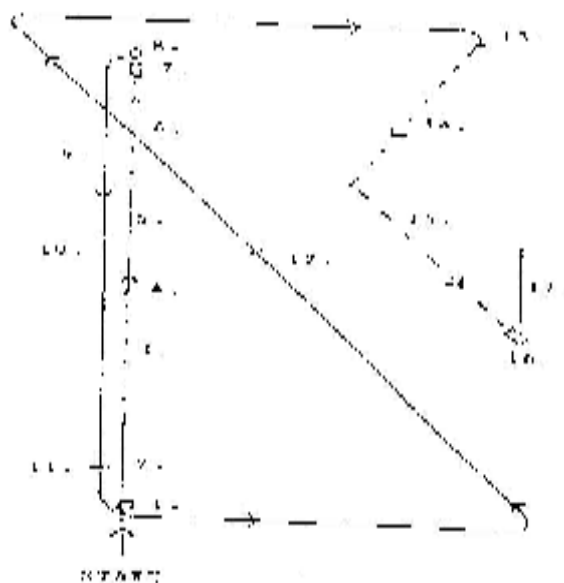

DIVISION 6L - Horse Training: English (Points 10, 5, 3)

CLASS NO. 1 - Two-Year-Old Under Saddle - English

- Open only to two-year-old fillies and geldings. Animal will show with a D or O ring snaffle. The use of a running martingale is permissible, not mandatory. Horses will be direct reined only. Horses will be judged at walk, trot and canter. Other tasks may be asked to do: halt from walk, dismount and mount, unsaddle and saddle up, back while dismounted, name parts of animal, equipment and nutrition.

CLASS NO. 2 - Three-Year-Old Under Saddle - English

- Same as two year. Rider will have horse lengthen and reduce gaits as directed by judge. Must perform Pattern #12. Other tasks: Same as two year old and identify leads.

PATTERN #12

Three-Year-Old Under Saddle - English

Retire to one end of the arena where each rider will perform the following pattern individually:

- 1-2. Trot along side of fence about 100 feet
2. Stop
- 2-3. Turn on forehand (front pivot foot to stay in 2 foot circle) with hindquarter moving to the right
- 3-4. Trot back toward starting point along the fence
4. Stop
- 4-5. Turn on the forehand (front pivot foot to stay in 2 foot circle) with hindquarter moving to the left
- 5-6. Trot along fence striking into a right lead as the rider begins the Figure 8 and go around Circle A once at the canter
7. Drop to a trot
8. Pick up a left lead and go around Circle B at the canter
9. Drop to a trot
10. Pick up right lead and go around Circle A at the canter
11. Drop to a trot
12. Pick up left lead and go around Circle B at the canter
- 13-14. Trot a small circle to the left
- 14-15. Trot a small circle to the right
- 15-16. Trot
16. Stop
- 16-17. Back 10 feet
17. Stop, settle horse for 10 seconds
Retire to judge for inspection

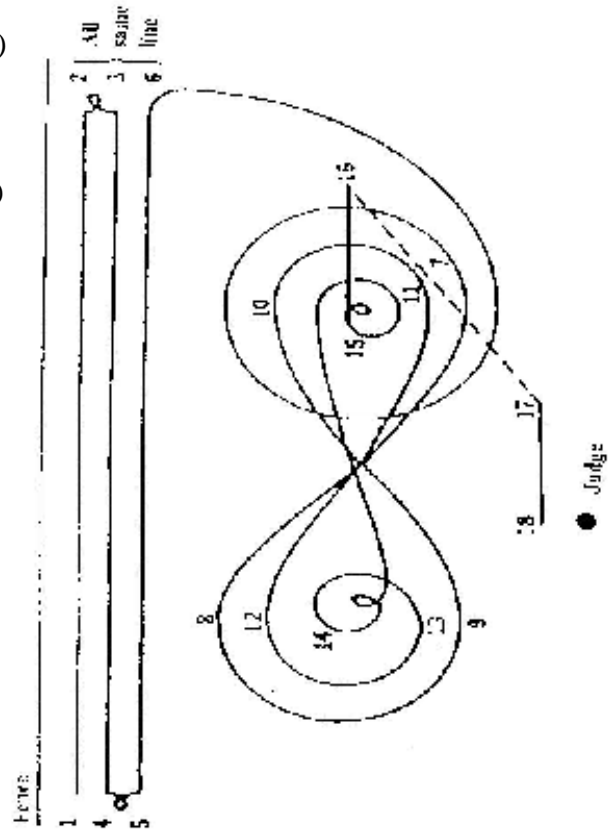

CLASS NO. 3 - Four-Year-Old Under Saddle - English

- Same as three-year-old class. Must perform Pattern #13.

PATTERN #13

Four-Year-Old Under Saddle - English

1. Sit trot
2. Side pass right 30° angle to fence
3. Rising trot
4. Halt turn on the haunches 180° right
5. Sit trot
6. Side pass left 30° angle to fence
7. Posting trot
8. Post extended trot
9. Sit two strides; canter left lead
10. Drop to trot change lead
11. Halt - settle for 5 seconds, canter left lead
12. Halt - settle for 5 seconds, canter right lead
13. Simple change
14. Halt turn on haunch 180° right - 180° left
15. Settle horse 3 seconds and back 10 feet
16. Retire to judge

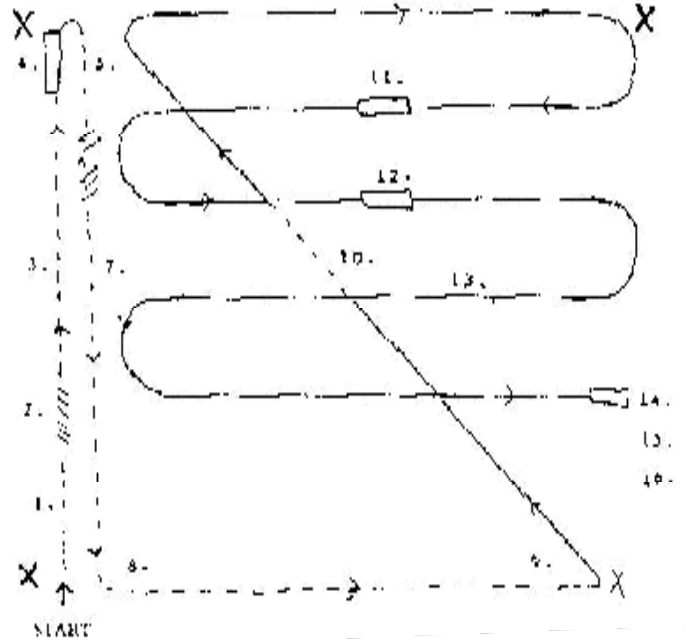

CLASS NO. 4 - Five-Year-Old Under Saddle - English

- Judged on ability to quietly and accurately perform pattern # 14.

PATTERN #14

Five-Year-Old Under Saddle - English

1. Sitting trot
2. Halt turn on the haunches left 180°
3. Sitting trot
4. Halt turn on the haunches right 180°
5. Posting trot
6. Canter left lead
7. Flying change
8. Flying change
9. Flying change
10. Halt
11. Turn on forehand 180° (either direction), settle 5 seconds - move off at sitting trot
12. Halt, rein back 10 feet

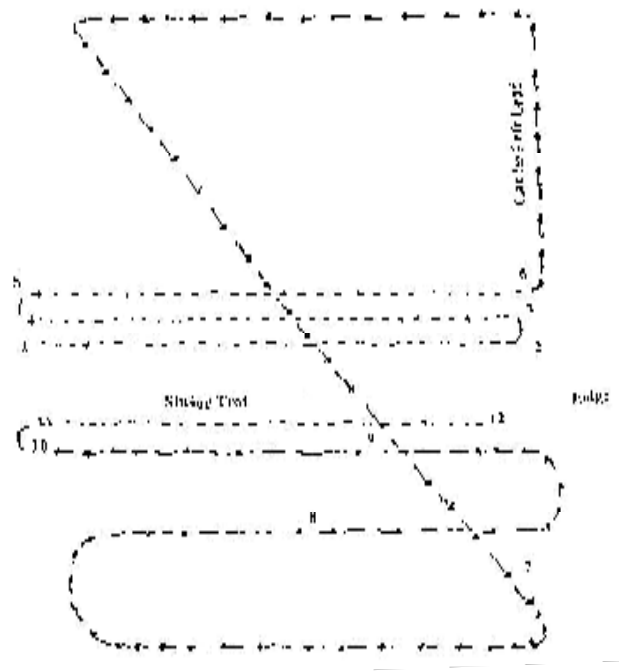

DIVISION 6M - Horse Seat Equitation Over Fences (Points 8, 4, 2)

- Rules are: Hard hats with leather-type chin straps are mandatory during jumping events and practices. Riders must wear headgear passing the AHSA standards. Horse must be four-years old or older. Member must be enrolled in English Horsemanship III or English Training - five-year-old horse to enter hunt seat over fences.
- These are major faults and may be cause for elimination: A refusal, loss of stirrup, or trotting while on course when not part of the test.
- Judged on ability to quietly and accurately perform Pattern #15.

CLASS NO. 1 - Junior Hunt Seat Equitation Over Fences

- Riders 13 years old and under.--Judged on horse's performance and ability to carry a rider in the hunt field. Jumps not to exceed 2' 3".

CLASS NO. 2 - Senior Hunt Seat Equitation Over Fences

- Riders 14 years and older. Jumps not to exceed 2' 6".
- Judged same as Junior Hunt Seat.

PATTERN #15

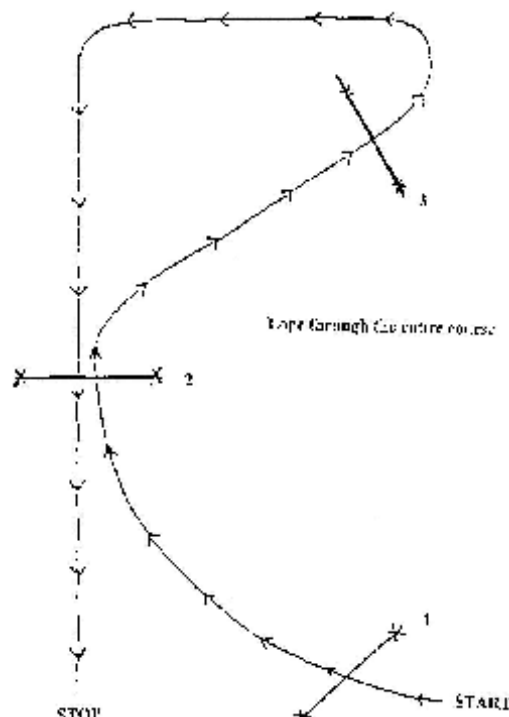

DIVISION 6N - Bareback Equitation (Points 8, 4, 2)

- Riders will be judged on seat, feet, hands, ability to control the horse and the suitability of the horse to the rider. Performance of the horse is not to be considered more important than the method used by the rider to obtain them. NO chaps allowed.
- No spurs are allowed in bareback.
- Members will be judged at a walk, trot and canter both ways of the ring. One or all contestants may be asked to:
 - Back
 - Name the parts of the horse and/or tack
 - Individual pattern at discretion of the judge
 - Dismount and mount

CLASS NO.

1. Senior Division 14 and Over
2. Junior Division 9 - 13 Years

DIVISION 6O - Trail Classes (Points 8, 4, 2)

- The trail class will be judged separate from the other classes. Only 4-H members in Horse Projects may enter. This class will be judged on the performance of the horse in maneuvering the obstacles. The horse should work with a reasonably loose rein without undue restraint. The judge will have the right to ask for rail work.
- Six obstacles will be used, of which three will be mandatory and three others selected from an approved list. The distance between obstacles shall be at the discretion of the judge.
- Props may be changed due to availability.

CLASS NO.

1. Senior Division - 14 & over
2. Junior Division - 9 - 13 years
3. Yearling

Mandatory Obstacles:

- Opening, passing through and closing gate. (Use a gate which will not endanger horse or rider; gate constructed with a minimum of 50 in. from the top of the gate to the ground and a minimum width of 4 ft.)
- Ride over a wooden bridge. (Bridge should be of sturdy construction with a minimum width of 36 in. and with non-slip ramp approach.)
- Back through "L" shaped course at least 30 in. in width or back a triangle pattern through three oil drums.

Optional Obstacles:

- Ride over at least four (4) logs
- Water Hazard
- Walk over animal hide
- Walk over single pole (obstacles not more 24 in. high)
- Carry object from one part of arena to another (only objects which reasonably might be carried on a trail ride may be used)
- Put on and remove slicker
- Dismount and lead horse over obstacles not less than 12 in. high or over 18 in. in height
- Remove and replace material from mailbox
- Side pass

- Obstacle consisting of four logs or rails each 5 to 6 feet long, laid in a square
- Each contestant will enter the square by stepping over the log or rail at the designated side. When all four feet are inside the square, the rider will execute a 360° turn (right or left), pause and depart by stepping over the log or rail immediately opposite the side of the entry.
- Ground tying (dismount, walk about 10 to 15 feet and return and mount; also to be judged on dismounting and mounting)
- Rail work at the discretion of the judge
- NO bales of hay or straw will be used in a trail class because of the danger of catching feet or shoes in string or wire.
- NO tires will be used in trail class because of the danger of catching feet in tires.
- While horse is in motion, rider's hands shall be clear of horse to avoid cuing. Horses to be penalized by an unnecessary delay while approaching obstacle. Judges are encouraged to advance on to the next obstacle any horse taking excessive time at an obstacle.

DIVISION 6P - Driving (Points 10, 5, 3)

- Must be enrolled in the Driving Horse Project to be eligible to compete in this class.

Level I - Driving

- Ground driving only with no cart.
- Demonstrate haltering and leading your horse safely at a walk and a trot.
- Ground drive horse in a simple pattern to include a circle, figure 8, a stop and backing up 10 feet.
- Demonstrate proper way to hold lines with a whip and without a whip

CLASS NO.

1. Single harness
2. Double harness

Level II - Driving

- Horse(s) are hitched to a cart.
- Demonstrate how to safely harness and hitch horse.
- At a walk, drive through a serpentine.
- At a walk, drive a figure 8.
- On the rail, demonstrate a controlled slow trot

- On the rail, demonstrate a controlled extended trot.
- Trot a figure 8 at a slow trot.
- Demonstrate how to properly reverse directions in an arena at a trot.
- Back up 10 feet.
- Stand quietly for two minutes.

CLASS NO.

3. Single harness
4. Double harness

Level III - Driving

- Demonstrate harnessing your horse or team.
- Demonstrate gait transitions from a walk to a controlled slow trot, to an extended trot and back to a walk and finally a stop.
- Drive a simple precision driving course that includes:
 - Trotting a figure 8 using cones to mark the centers of each loop.
 - Trotting a serpentine of five cones.
 - Walking with right wheels between poles.
 - Trotting with left wheels between poles.
 - Stopping at markers, back a given distance, stand for 20 seconds.

CLASS NO.

5. Single harness
6. Double harness

Level IV - Driving

CLASS NO.

7. Notebook with plans, records, pictures, reports etc., pertaining to project requirements. Be available for interview.

DIVISION 6Q - Draft or Light Horse Training (Points 10,5,3)

- Members must be 12 years of age or older during the current 4-H year and have completed two levels of Driving before taking the Draft or Light Horse Training Project.
- A Training Project horse cannot be used in the Driving Project.

CLASS NO.

1. Yearling
 - Will compete with yearlings in the Training a Colt to Maturity.

CLASS NO.

2. Two-year-old
 - Be able to exhibit basic knowledge of parts of the harness and hitch.
 - To be driven either in breaking harness or full harness.
 - To be driven in a full circle both directions.
 - Stop and back.

CLASS NO.

3. Three-year old
 - To be driven pulling a stone boat, or tow or four wheel vehicle.
 - Chariots will not be allowed.
 - Simple maneuvers will be required.
 - Be able to exhibit basic knowledge of parts of the harness and hitch.

CLASS NO.

4. Four-year-old
 - To be hitched and rehitched in arena - head man required.
 - Must follow simple pattern.
 - May be driven as a team with an older broke horse but not mandatory.

CLASS NO.

5. Five-year-old
 - Horse to be harnessed before judge in safe, enclosed area.
 - Must follow an advanced pattern with precision driving skills.
 - May be driven as a team with an older broke horse but not mandatory.



DIVISION 6R - Ranch Horse Class (Points 10, 5, 3)

- This class will be judged on performance of horse and rider. Following equipment will be required when competing in the class: saddle, bridle, saddle pad, saddle bag, rope and hobbles.
- Member must be enrolled in the Ranch Horse Project to be eligible to compete in this class.
- The judge may ask contestant to describe the care of equipment, basic nutrition or basic facilities for a horse. Competition will consist of at least six skills selected from the following lists:

CLASS NO.

1. Level I
 - Mount and dismount safely
 - Walk to lope to walk
 - Stop from walk, trot and/or lope
 - Recognize leads
 - Cross a bridge
 - Walk your horse through water
 - Back in a straight line
 - Lope in a circle to demonstrate "handle"
 - Open, walk through and close gate properly while leading your horse
 - Lead your horse safely beside and behind you
 - Demonstrate roping on the ground
 - Demonstrate different roping techniques - heading/healing

CLASS NO.

2. Level II
 - Cross logs
 - Move through brush
 - Demonstrate safe riding on steep hills, side hills, bogs, muddy areas, etc.
 - Execute side pass and/or explain uses on a ranch
 - Execute simple lead change and explain importance of recognizing leads
 - Ride quietly through a herd of cows
 - Slowly move a herd of cows, stop and hold them in place

- Open, pass through and close a hinged gate while mounted
- Identify different brands and explain why needed
- Conditioning your horse:
 - To a rope - twirl it nearby and/or drag near legs and feet, over back
 - To a slicker
- Demonstrate roping skills from the ground - rope heeling dummy, moving targets, etc.
- Any task from Level I

CLASS NO.

3. Level III
 - Execute a rollback on a fence
 - Execute a rollback away from fences
 - Explain importance of above maneuvers on a ranch
 - Back horse through an obstacle and in a circle
 - Safely lead another horse from your horse
 - Execute flying change of leads and/or explain importance
 - Hold a cattle herd while someone works cows from it
 - Put on and take off slicker while mounted
 - Demonstrate reading brands and brand location
 - Rope off your horse at a stationary object
 - Any task from Level I & II

CLASS NO.

4. Level IV
 - Demonstrate giving a horse a shot
 - Demonstrate ear tagging cattle
 - Demonstrate how to hobble a horse
 - Demonstrate how to make an emergency set of hobbles
 - Execute all maneuvers in a working-cow-horse pattern
 - Cut and drive selected cows or pairs
 - Work in a corral roping and/or sorting calves
 - Any task from Level I, II, & III

DIVISION 6S - Horse Judging (will be displayed indoors) (Points 4, 2, 1)

CLASS NO.

1. Notebook with plans, records, pictures, reports etc., pertaining to project requirements. Be available for interview.

DIVISION 6T - Horse Showing (will be displayed indoors) (Points 4, 2, 1)

CLASS NO.

1. Notebook with plans, records, pictures, reports etc., pertaining to project requirements. Be available for interview.

DIVISION 6U - Careers with Horses (will be displayed indoors) (Points 4, 2, 1)

CLASS NO.

1. Notebook with plans, records, pictures, reports etc., pertaining to project requirements. Be available for interview.

DIVISION 7 - SELF-DETERMINED (All Livestock) (Points 10, 5, 3)

- Each exhibit receives a ribbon placing.
- Member must be present for an interview during the judging.

CLASS NO.

1. Live animal

DIVISION 8 - POULTRY

- Exhibit coops for poultry can be furnished by the Fair. Contact Fair Office to reserve cages. Members must have possession of poultry by July 1st. Must state breed and number on entry tag. Single breeding entries may also be used in a pair.
- Any bird may be shown for Sr. or Jr. showmanship.
- Entry of a single bird may be sold at the 4-H/FFA Livestock Sale if the exhibitor receives a blue or red ribbon.
- The exhibitor must be present to show their entry during the judging and sale.
- Brood of a female must be hatched by her in current year.

DIVISION 8A – Market Poultry (Points 6, 3, 1)
Market Poultry is open to Fallon County 4-H/FFA members only.

CLASS NO.

1. 1 bird less than a year

DIVISION 8B - Breeding Chickens (Points 6, 3, 1)

CLASS NO.

	Male less than year	Male over a year	Female less than yr	Female over a year	Duo: 1male+1female	Female and brood
Egg Type	1	2	3	4	5	6
Dual Purpose	7	8	9	10	11	12
Ornamental	13	14	15	16	17	18

DIVISION 8C - Breeding Turkey (Points 6, 3, 1)

CLASS NO.

	Male less than year	Male over a year	Female less than yr	Female over a year	Duo: 1male+1female	Female and brood
Tame	1	2	3	4	5	6
Wild, Ornamental	7	8	9	10	11	12



DIVISION 8D - Breeding Duck (Points 6, 3, 1)

CLASS NO.

	Male less than year	Male over a year	Female less than yr	Female over a year	Duo: 1male+ 1female	Female and brood
Domesticated	1	2	3	4	5	6
Wild	7	8	9	10	11	12

DIVISION 8E - Breeding Goose (Points 6, 3, 1)

CLASS NO.

	Male less than year	Male over a year	Female less than yr	Female over a year	Duo: 1male+ 1female	Female and brood
Domesticated	1	2	3	4	5	6
Wild	7	8	9	10	11	12

DIVISION 8F - Game Bird (Points 6, 3, 1)

* Please specify Breed

CLASS NO.

	Male less than year	Male over a year	Female less than yr	Female over a year	Duo: 1male+ 1female	Female and brood
All Game Birds	1	2	3	4	5	6

DIVISION 9 - RABBITS (Points 6, 3, 1)

- Exhibitor must be present to show the animals during judging.
- Members must bring their own cages to exhibit rabbits in.
- Rabbits under 6 weeks of age and pregnant does will not be shown.
- Members must have possession of rabbit(s) by July 1st.
- Members may exhibit 2 entries per Class if animals are different breeds. **MUST STATE BREED ON ENTRY TAG**
- Market Rabbit is open to Fallon County 4-H/FFA members only

DIVISION 9A - Breeding Rabbits (Points 6, 3, 1)

CLASS NO.

1. One doe, under 6 months old (State Breed)
2. One doe, 6 months to under 12 months old (State Breed)
3. One doe, over 12 months old (State Breed)
4. Doe and litter
5. One buck, under 6 months old (State Breed)
6. One buck, 6 months to under 12 months old (State Breed)
7. One buck, over 12 months old (State Breed)

DIVISION 9B - Market Rabbit (Points 6, 3, 1)

Market Rabbit is open to Fallon County 4-H/FFA members only

CLASS NO.

1. Market rabbit, under 6 months old (State Breed)



DIVISION 10 – SHEEP

DIVISION 10A - Market Lambs (Points 10, 5, 3)

- Market Lamb is open to Fallon County 4-H/FFA members only
- 4-H members must be enrolled in the Market-Lamb Project to exhibit market sheep.
- Only lambs under 1 year of age may be shown.
- Feeder or market-lamb status of lamb entry will be determined at the time of weigh-in. Lambs less than 80 pounds will be considered feeder lambs.
- Members must have possession of animals by June 1st.
- Members can sell one blue or red ribbon market lamb. No white ribbon lambs will be allowed to sell.
- Market lambs can be all breeds - ewes or wethers.

CLASS NO.

1. Single market lamb
2. Pen of three market lambs: Individual, Family, or Club.
3. Single feeder lamb.
4. Pen of three feeder lambs: Individual, Family, or club.

DIVISION 10B - Breeding Sheep (Points 10, 5, 3)

- 4-H members must be enrolled in Sheep Breeding to exhibit breeding sheep
- Members are encouraged to exhibit market lambs produced by his/her own breeding project animals. However, the same animal cannot be entered in both the market and the breeding class at the Fair.
- Members must have possession of animals by June 1st.
- Sheep entered in breeding class will be judged on breed type, characteristics, quality and development for age. A flock consists of one ram, two ewes and two lambs. All animals in a flock entry may also be shown as singles and must be entered before judging begins.
- The top breeding ram and ewe of each breed are eligible for the 4-H over-all trophies.
- 4-H members taking a market or breeding sheep project must also be enrolled in the appropriate manual based project. Their level in these projects will be determined by age and skill level.

CLASS NO.

	Ram under 1 year	Ram 1 yr & under 2	Ram 2 yr & under 4	Ewe under 1 year	Yearling Ewe 1 year & under 2	Ewe 2 year & under 4	Pen of 3 Ewe lambs	Flock
Ram-bouillet	1	2	3	4	5	6	7	8
Hampshire	9	10	11	12	13	14	15	16
Targhee	17	18	19	20	21	22	23	24
Columbia	25	26	27	28	29	30	31	32
Suffolk	33	34	35	36	37	38	39	40
Cross-bred	41	42	43	44	45	46	47	48
Other	49	50	51	52	53	54	55	56



DIVISION 11 – SHOWMANSHIP (Points 10, 5, 3)

1. 4-H and FFA members will participate in showmanship together. All 4-H and FFA members must exhibit in the division in which they participate in the showmanship contest. All livestock members are encouraged to enter showmanship classes.
2. All animals in the class must show evidence of fitting and handling.
3. The contestant **MUST** be able and ready to prove to the judge his ability to groom and fit animals.
4. Contestants will be divided into three divisions:

Senior Division: Members must be 14 years or age or older before October 1, 2009.

Junior Division: Members must be 13 years of age or younger before October 1, 2009.

Novice Division: Members will consist of first year showman age 10 and under before October 1, 2009. Members eligible for Novice Showmanship may choose to show as a novice or a junior member, but not both. (Novice showman do not advance on to round robin)

5. All contestants will receive a ribbon awarded by the judge on the Danish System.
6. Dress code required for the member's livestock project must be followed when competing in showmanship contest with that animal.
7. A grand and reserve will be selected in both the Senior and Junior Division Round Robin contests as decided by the judges.

The Round Robin Showmanship competition will be held at 8:00 a.m. on Saturday of the fair in the livestock barn show arena.

1. Grand and Reserve Champion Showman selected in each of the following divisions will be eligible to advance to the Round Robin competition: (1) Beef Showmanship, (2) Horse Showmanship, (3) Dairy-Cattle Showmanship, (4) Non-Fiber Goat Showmanship, (5) Swine Showmanship, and (6) Sheep Showmanship

2. The animals shown by the Grand and Reserve showman in each division will also advance to the Round Robin competition.
3. Round Robin contest consists of Beef, Horse, Dairy cow, Non-Fiber Goat, Swine, and Sheep even if a grand or reserve champion is not awarded in each specie. If a specie did not qualify for Round Robin, superintendent will choose a suitable animal of that specie.
4. An overall Senior and Junior Division Grand Champion will be selected and awarded a special prize.

CLASS NO.

1. Senior Beef
2. Junior Beef
3. Novice Beef
4. Senior Horse
5. Junior Horse
6. Novice Horse
7. Senior Dairy Cattle
8. Junior Dairy Cattle
9. Novice Dairy Cattle
10. Senior Goat (Dairy, Pygmy, Meat and Market)
11. Junior Goat (Dairy, Pygmy, Meat and Market)
12. Novice Goat (Dairy, Pygmy, Meat and Market)
13. Senior Fiber Goat
14. Junior Fiber Goat
15. Novice Fiber Goat
16. Senior Swine
17. Junior Swine
18. Novice Swine
19. Senior Sheep
20. Junior Sheep
21. Novice Sheep
22. Senior Poultry
23. Junior Poultry
24. Novice Poultry
25. Senior Rabbit
26. Junior Rabbit
27. Novice Rabbit
28. Senior Dog
29. Junior Dog
30. Novice Dog
31. Senior Cat
32. Junior Cat
33. Novice Cat

DIVISION 12 - SWINE (Points 10, 5, 3)

- The Market Swine Class is only open to Fallon County 4-H/FFA members. All swine will be shown with a riding crop, bat, or pole in the sheep show ring. Member must have possession of animal by June 1st. Commercial-finish weight is 235 to 280 lbs.
- Member must be registered in the appropriate Swine project to exhibit Market Swine or Breeding Swine at the fair, but same animal cannot be entered in both market class and breeding class at the fair.
- Feeder or market swine status of swine entry will be determined at the time of weigh-in. Swine less than 200 pounds will be considered feeder swine.

DIVISION 12A - Market Swine

CLASS NO.

1. Market Swine
2. Pen of three market swine: Individual, Family, or Club
3. Weaned feeder hog

DIVISION 12B - Breeding Swine

- Individual exhibits of gilt and boar under 1 yr. may be shown or used as part of Class shown as litter.



CLASS NO.

	Boar under 1	Boar 1 yr & under 2	Gilt under 1 year	Sow over 1 year	Litter of 4 or more
Duroc	1	2	3	4	5
Chester White	6	7	8	9	10
Hampshire	11	12	13	14	15
Yorkshire	16	17	18	19	20
Crossbred	21	22	23	24	25
Other	26	27	28	29	30

DIVISION 13 - WOOL (Points 4, 2, 1)

- The purpose of this show is to educate wool growers to produce higher-value fleeces. Twelve months' growth of wool is the minimum permitted, except in the case of yearling fleeces.
- All entries must be in the name of the grower.
- Facts affecting exhibit are: discoloration by excessive moisture and weakness of staple.
- DO NOT insert class number—this will be determined by the judge.

DIVISION 13A - Ewe Wool Fleece

CLASS NO.

1. 62's Finer
2. 58-60 Medium Grade
3. 56's Courser
4. Carpet Wools

DIVISION 13B - Ram Wool

CLASS NO.

1. 62's Finer
2. 58-60 Medium Grade
3. 56's Courser
4. Carpet Wools

DIVISION 13C - Fiber (Angora, Cashmere, Etc.)

CLASS NO.

1. Type A (3" + ches curly)
2. Type B (3"- 6" wavy with guard hairs)
3. Type C (fine 1"-3" long, straight but does show crimp)

FFA YOUTH AGRICULTURAL ED. INDOOR

(Points 8, 4, 2)

DEPARTMENT U

DIVISION 1 - AG COMMUNICATIONS

DIVISION 1A - Communications

CLASS NO.

1. Your first article
2. Your first radio add
3. Speech
4. Any other related project

DIVISION 1B - Parliamentary Procedure

CLASS NO.

1. Manual of correct way to run a meeting
2. Breakdown of motions
3. Any other related project

DIVISION 1C - Ag Sales & Service

CLASS NO.

1. Sales ad for feeds, seeds, fertilizer, chemicals, etc.
2. Other Ag related sales advertisement
3. Any other related project

DIVISION 1D - Photography

CLASS NO.

1. Reporters chapter scrapbook
2. Photo album of chapter events
3. Any other related project

DIVISION 1E - Records and Manuals

CLASS NO.

1. Four year record book
2. Livestock record book
3. Agribusiness record book
4. FFA chapter secretary book
5. FFA chapter treasure book
6. Any other related project

DEPARTMENT U

DIVISION 2 - LIVESTOCK

DIVISION 2A - Beef Production

CLASS NO.

1. Breeding stock display
2. Feed display
3. Genetic explanation
4. Market animal display
5. Any other relate project

DIVISION 2B - Dairy Production

CLASS NO.

1. Marketing of Dairy Products
2. Records of individual and herd milk production
3. Correct handling of milk and dairy by-products
4. Any other related project

DIVISION 2C - Equine Science

CLASS NO.

1. Breeding Stock display
2. Feed display
3. Training Display
4. Any other related project

DIVISION 2D - Poultry Production

CLASS NO.

1. Incubator display
2. Feed Display
3. Egg production display
4. Any other related project

DIVISION 2E - Sheep Production

CLASS NO.

1. Feed display
2. Wool display
3. Breeding stock display
4. Market animal display
5. Any other related project

DIVISION 2F - Small Animal Production

CLASS NO.

1. Feed display
2. Animal production display
3. Any other related display

DIVISION 2G - Specialty Animal Production

CLASS NO.

1. Feed display
2. Display of animal purpose
3. Any other related project

DIVISION 2H - Swine Production

CLASS NO.

1. Feed display
2. Breeding animal display
3. Market animal display
4. Any other related project

DEPARTMENT U**DIVISION 3 - PLANT SCIENCE****DIVISION 3A - Cereal Grain Production**

CLASS NO.

1. Display of cleaned grain
2. Display of planned crop rotation
3. Any other related project

DIVISION 3B - Feed Grain Production

CLASS NO.

1. Display of feed grain
2. Display of planned crop rotation
3. Any other related project

DIVISION 3C - Floriculture

CLASS NO.

1. Marketing ad for flowers
2. Display of flower arrangement
3. Display of flower packing
4. Dried flower and/or bouquet
5. Any other related project

DIVISION 3D - Forage Production

CLASS NO.

1. Display of harvested crop
2. Display on quality analysis of forage crop
3. Any other related project

DIVISION 3E-Vegetable and Fruit Production

CLASS NO.

1. Fruit or vegetable production display
2. Dried fruit or vegetable
3. Any other related project

DIVISION 3F - Specialty Crop

CLASS NO.

1. Display of crop purpose
2. Display of crop production
3. Any other related project

DIVISION 3G - Nursery Crop Production

CLASS NO.

1. Display of nursery plants
2. Any other related project

DEPARTMENT U**DIVISION 4 - NATURAL RESOURCES****DIVISION 4A - Environmental Science**

CLASS NO.

1. Display of waste management
2. Display of energy use
3. Display of resource use
4. Any other related project

DIVISION 4B - Landscape Design And Management

CLASS NO.

1. Display of landscape improvement project
2. Any other related project

DIVISION 4C - Soil and Water Production

CLASS NO.

1. Water quality display
2. Water treatment display
3. Soil improvement display
4. Erosion prevention display
5. Any other related project

DIVISION 4D - Wildlife Management

CLASS NO.

1. Display of wild life habitat improvement
2. Any other related project

DEPARTMENT U
DIVISION 5 - AG PROCESSING

DIVISION 5A - Food Processing

CLASS NO.

1. Canning objects
2. Dried foods
3. Any other related project

DIVISION 5B - Meats

CLASS NO.

1. ID of beef cuts
2. ID of lamb cuts
3. ID of pork cuts
4. ID of poultry cuts
5. Any other related project

DEPARTMENT U
DIVISION 6 - AG MECHANICS

DIVISION 6A - Ag Welding

CLASS NO.

1. Display of OAW welds
2. Display of SMAW welds
3. Display of GMAW welds
4. Display of TIG welds
5. Plasma arc cut out
6. Any other welded project

DIVISION 6B - Ag Construction

CLASS NO.

1. Small animal shelter
2. Display of wood project
3. Any other related project

DIVISION 6C - GPS in Agriculture

CLASS NO.

1. Map of field or range
2. GPS display
3. Any other related project

**DIVISION 6D - Prospective FFA/Ag Students
(Junior High)**

CLASS NO.

1. Sheet metal project
2. Wood project
3. Leather project
4. Any other related project

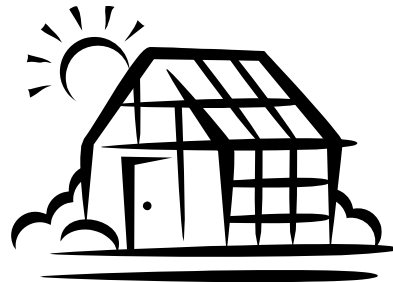

SPECIAL YOUTH AWARDS LIST

MONTANA ANGUS ASSOCIATION will award a belt buckle to the top 4-H or FFA Black Angus Breeding Exhibit.

MONTANA ANGUS AUXILIARY will offer a jacket award to the top 4-H/FFA overall breeding exhibit winner if a Black Angus and has competed against at least three other exhibitors.

THE MONTANA HEREFORD ASSOCIATION will award a wind breaker jacket to the exhibitor of a Grand Champion Steer if properly documented as a Hereford, to the Top Steer of Merit on the county level if animal is at least 50 % Hereford ancestry and to the Top Breeding Female if a purebred Hereford.

THE MONTANA SIMMENTAL ASSOCIATION will give an award for the Grand Champion Market Steer, Grand Champion Carcass and Grand Champion Female for 4-H or FFA, if the animal is identified on their stall or barn card as being Simmental or Simmental cross.

THE MONTANA GELBVIEWH ASSOCIATION will pay \$10 to any 4-H or FFA exhibitor who receives a blue ribbon on their Gelbvieh or Gelbvieh-cross animal at a county fair. In addition to the \$10 for a blue ribbon, Grand and Reserve Champion animals, where competing in a minimum group of 5, will receive \$25 and \$15 respectively.

THE AMERICAN SALERS ASSOCIATION will offer \$100 for a steer and \$50 for a heifer if the animal is a Grand Champion, competed in a multi-breed competition and is at least 50% Salers out of a registered Salers sire or female. Eligible 4-H and FFA youth must submit a completed application and picture of animal.

BAKER COWBELLES sponsor the Rodeo Queen Contest. They will award a show halter to the youngest 4-H exhibitor of a blue ribbon Market Beef.

THE KONO FAMILY will award a Sheep Resource Book to the youngest first year 4-H member exhibiting a sheep in memory of J.R. Kinsey.

MURPHY BROTHERS QUARTER HORSE RANCH of Baker, Montana will award a saddle blanket to the top 4-H yearling Horse.

THE CHILDREN OF HAROLD MAJOR will award a traveling plaque to the 4-H Club or FFA Chapter judged to be the "Top Club Herdsman" for sheep in memory of Harold Major, Sheep Superintendent for the Fallon County Fair from 1959 through 1972.

BROWN'S CUSTOM FEEDS will award a traveling plaque to the 4-H Club or FFA Chapter judged to be the "Top Club Herdsman" for swine.

DEGRAND'S ANGUS will award a traveling plaque to the 4-H Club or FFA Chapter judged to be the "Top Club Herdsman" for beef.

DAVE AND PENNY KONO will award a traveling plaque to the 4-H Club or FFA Chapter judged to be the "Top Club Herdsman" for goat in memory of J.R. Kinsey.

THE FAMILY OF PAT MURPHY will award a traveling plaque to the 4-H Club or FFA Chapter judged to be the "Top Club Herdsman" for horse in memory of Pat Murphy, Livestock Superintendent for the Fallon County Fair from 1960 through 1970.

THE GRAY FAMILY will award Beef Awards to the "Top Flight Winners", and "Top SOM (Steer of Merit) Carcass Winner".

EQUITY CO-OP OF BAKER, MT will award a belt buckle to the Grand Champion Market Steer, Grand Champion Market Swine, and Grand Champion Market Sheep.

STONE JONNY BOER GOATS will award a belt buckle to the Grand Champion Market Goat

DOCS RABBIT RANCH will award a Rabbit Resource Book to the youngest 4-H Rabbit exhibitor.

JERRY & SYLVIA LANDA will award a \$100 Savings Bond to the Top Pig Carcass.

JERRY & SYLVIA LANDA will award a \$100 Savings Bond to the Top Lamb Carcass.

Fallon County Fair 4-H Livestock Buyers 2009

*Ace Ranch
All 4 U Flowers
Anipro Feeds
Baker Club
Baker Rexall Drug
Bank of Baker
Brown, John
Brown's Custom Feeds
C & M Oilfield Service
Continental Resources
D & D Oilfield Service
Dakota Community Bank
Dakota Western Bank
Dave's Welding
Doc's Rabbit Ranch
Encore Operating L.P.
F & D Oilfield Maintenance
Fallon County Abstract
Farmer's Elevator
G & R Custom Metal
Gookin Trucking
Griffith Excavating
Grube, Tim
Horizon Farm
Kono, Dave & Penny*

*K Star Production
KT Trucking
Landa Angus
Miles City Livestock
Phiefle Construction
Ponderosa Ranch
Reynolds Supermarket
Rost & MacKay Fencing
Rustad Hay Grinding
Sandstone Creek Ranch
Schiefelbein Feeders
Schneider Angus
Schreve, Dave
Scranton Equity Feeds
Southeast Electric Co-Op Inc.
St. Onge Livestock
Stevenson & Sons Funeral Home
Taylor, Randy
Thee Body Shop
Trendline Vermeer Equipment
Walters, Vernon
West Plains Implement
Western Ranch Supply
Wiedmer Backhoe*

2009 Friends of 4-H Plaque Buyers

Horizon Implement

2009 Friends of Baker FFA Plaque Buyer

Rusley Maine Anjiou

2009 Friends of Plevna FFA Plaque Buyer

Superior Livestock

FALLON COUNTY FAIR AWARDS DONORS

*Baker Body Shop
Baker Hardware, Inc.
Bracket Butte Ranch
Brown's Custom Feeds, Inc.
C & M Oilfield Service
Campbell, James DDS
Dennis' Oilfield Service
Equity Cooperative of Baker
Espeland, Darryl M., D.O.
F&D Oilfield Maintenance
Farm Credit Services
Farmer's Elevator
Farmer's Union Oil Co.
First State Bank of Golva
Golva Co-Operative Elevator
Gray Inc.
Griebel, Marge
Gunrunner
Insurance Store
Johnson Black Simmental
K & S Electric, Inc.*

*Kono, Dave & Penny
Lawlers/Connie Moore
Leibee Vigortone
Logsdon, John & Linda
Murphy, Mike & Esther
Murphy Quarter Horses
Q.T. Inc.
Quality Transportation, Inc.
Reynolds
R & W Livestock Products
Reetz, James & Toni
Rieger, Donald & Eileen
Rising Angus Ranch
Rost Accounting & Tax Service
Rost & MacKay Fencing
Schwartz, Keith & Sharon
Spriggs, Steve & Bonnie
T Financial
Townsend Accounting Service
Verke Refrigeration
Willard Homemakers
Young, Denzil R., Attorney At Law*



